

Smart performance with innovative and ever-strong coil drive even under harsh working environments



Features

- ▶ Easy and quick auto-calibration
- ▶ Detecting RA (reverse acting) or DA (direct acting) automatically regardless of wrong air connections
- ▶ Available to use for single or double acting without any special adjustments
- ▶ Compact design allowing to be installed on small actuators
- ▶ Providing error messages against performance failures
- ▶ Possible to test the actuator with any fixed signal under a test mode
- ▶ Programmable characteristic curve with 17 points
- ▶ Wide operating temperature range -30 ~ +80 °C
- ▶ Improved control of high-friction globe and ball valves by eliminating an overshoot and a hunting
- ▶ Low air consumption
- ▶ Providing a mounting bracket to meet IEC 60534-6-1 for linear valves
- ▶ Supporting a NAMUR mounting pattern VDI/VDE 3845 (IEC 60534-6-2) and providing a multi-size mounting bracket for rotary valves

Options

- ▶ Output position transmitter (4 - 20 mA)
- ▶ 2 x alarm limit or micro switch (SPDT)
- ▶ Low temperature (- 40°C)
- ▶ Intrinsically safe type (IECEX / ATEX / TR-CU / KC Ex ia IIC T6/T5)
- ▶ HART communication
- ▶ Profibus PA communication
- ▶ Foundation Fieldbus communication

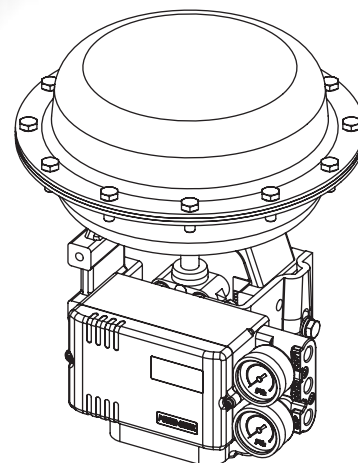

- SS2L (Linear Type)

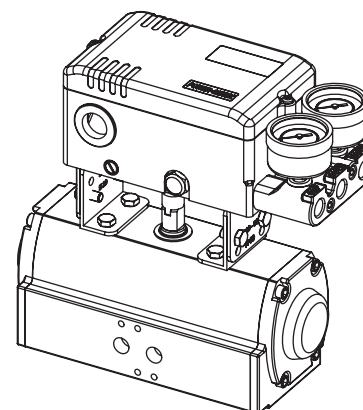

- SS2R (Rotary Type)

Specifications

Communication	Without	HART	Profibus - PA	Foundation Fieldbus
Input Signal / Bus voltage	4 - 20 mA @ 24 VDC		9 - 32 VDC	
Min. / Max. Current	3.6 mA / 50 mA		-	
Current Consumption	-		15mA	16mA
Voltage Drop (Resistance)	8.7 VDC(435Ω)	9.4 VDC(470Ω)	-	
Stroke / Angle	Linear type : 5 - 130 mm * Rotary type : 25 - 120°			
Air Supply Pressure	1.4 - 7.0 bar (20 - 100 psi), filtered, compressed dry and non-oiled to meet Class 3 of ISO 8573-1			
Output Pressure Range	0 - 100% of supply air pressure			
Air Capacity	80 l/min = 4.8 N ^m /h = 2.8 scfm (Sup = 1.4 bar) 233 l/min = 14 N ^m /h = 8.2 scfm (Sup = 6 bar)			
Air Consumption	2.8 l/min = 0.17 N ^m /h = 0.1 scfm (Sup = 1.4 ~ 6 bar)			
Characteristic	Linearity < ±0.3% F.S Hysteresis < 0.2% F.S		Sensitivity < 0.2% F.S Repeatability < 0.2% F.S	
Performance Characteristic	Linear, EQ %, Quick open, User set (17 points)			
LCD Indication	4-digit LCD indicator			
Adjustable Speed	1 - 1000 (lowest 1, highest 1000)			
Scan Time	2ms			
Shut-off Value	Range 0 - 10% of position signal			
Valve Action	direct action (DA) / reverse action (RA)			
Operating Temperature	- 30 ~ +80 °C (- 22 ~ +176 °F) **			
Pneumatic Connections	PT(Rc) 1/4 or NPT 1/4			
Electrical Connections	2 x PF(G) 1/2 , NPT 1/2 , M20 x 1.5			
Protection Class	IP66, Intrinsically safe (IECEX / ATEX / KC Ex ia IIC T6/T5)			
Body Material	Aluminum die-cast / powder-painted			
Weight	1.6 kg			

* Up to 200mm on request ** -40 °C on request

Principle of Operation

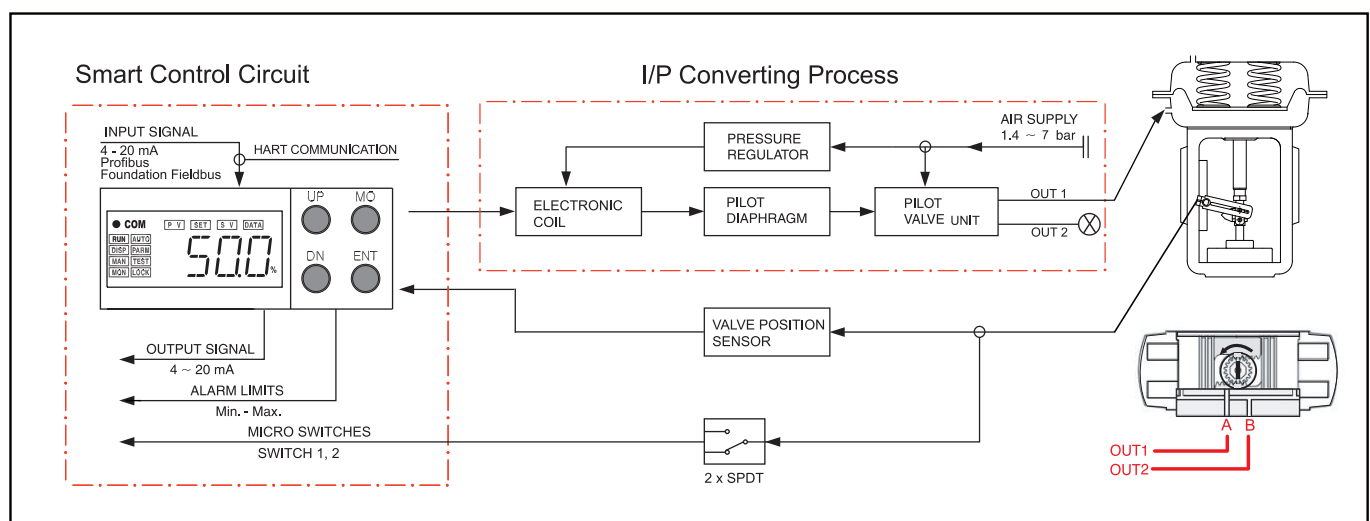

If 4-20 mA input signal(or Bus communication signal) is supplied, the micro processor compares input signal with position feedback and sends control signal to the I/P converting module. Pneumatic signal from the I/P converting module operates the valve and the valve stays at the desired position.

Mounting to Linear Actuator

- SS2L (Linear Type)

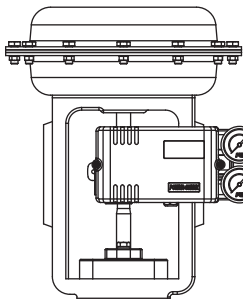

< Front View >

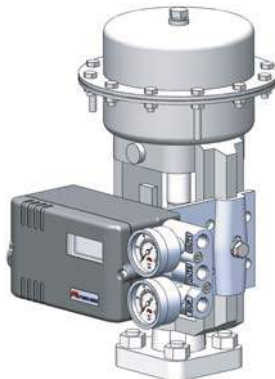

< Side View >

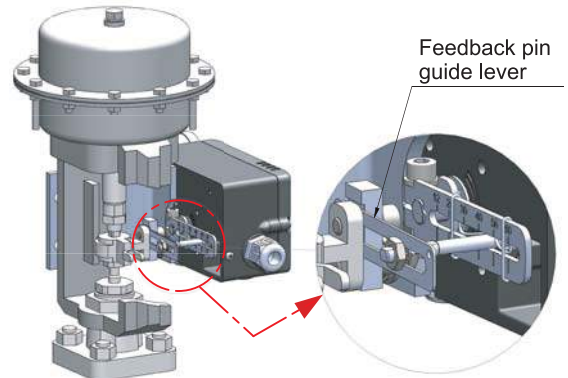

< Feedback Lever Connection >

"A" Type

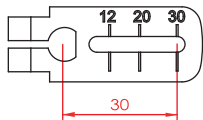

"B" Type

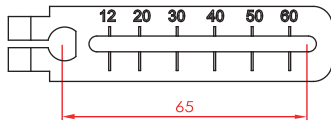

"C" Type

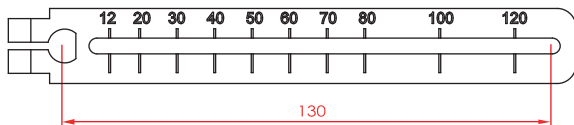

Feedback Lever

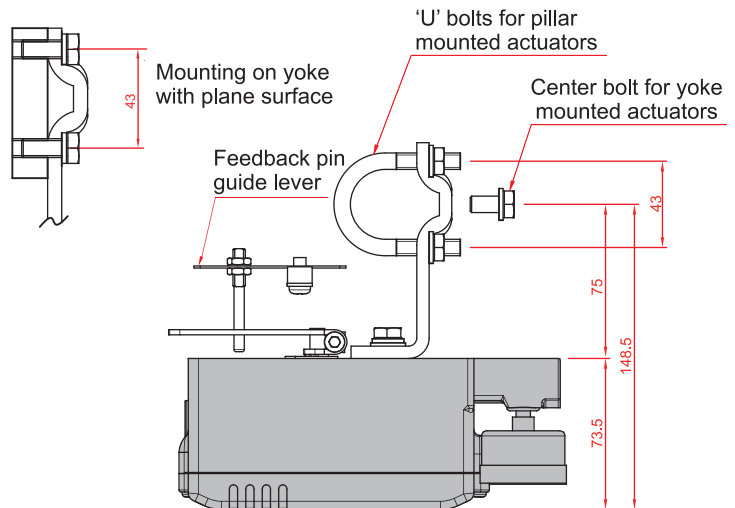

Mounting to linear actuators to IEC 60534 6-1

Mounting to Rotary Actuator

- SS2R (Rotary Type)

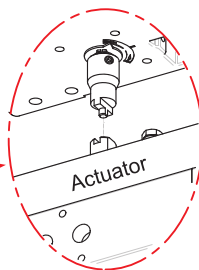
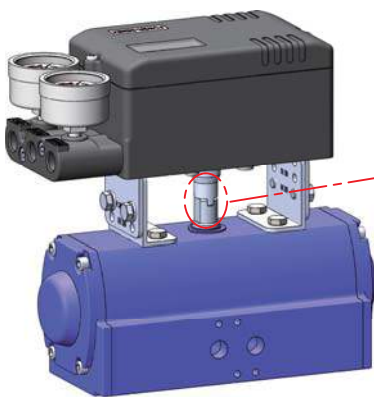

NAMUR Type Mounting
(VDI/VDE 3845,
IEC 60534-6-2)

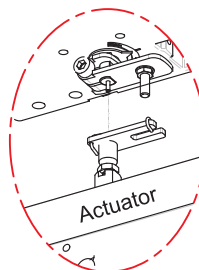

Fork Lever Type Mounting

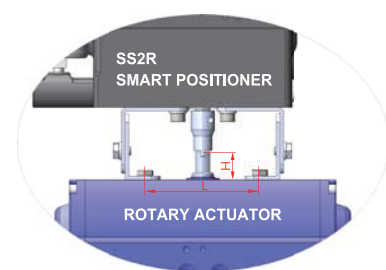

Size Variation of Multi-Size Bracket

- 1) 80 x 30 x 20 (H) , 4) 130 x 30 x 20 (H)
 - 2) 80 x 30 x 30 (H) , 5) 130 x 30 x 30 (H)
 - 3) 80 x 30 x 50 (H) , 6) 130 x 30 x 50 (H)
- H : Rotary Actuator Shaft Height
L : Length (80 or 130mm)

Air Connections

- SS2L (Linear Type)

Direct Acting (DA)		Reverse Acting (RA)	
<p>DA 1</p> <p>As the input signal increases, Valve stem moves downwards</p> <p>Actuator : DA</p>	<p>OUT2 must be plugged</p>	<p>RA 1</p> <p>As the input signal increases, Valve stem moves upwards</p> <p>Actuator : RA</p>	<p>OUT2 must be plugged</p>
<p>DA 2</p> <p>As the input signal increases, Valve stem moves downwards</p> <p>Actuator : DA</p>	<p>OUT1 must be plugged</p>	<p>RA 2</p> <p>As the input signal increases, Valve stem moves upwards</p> <p>Actuator : RA</p>	<p>OUT1 must be plugged</p>
<p>DA 3</p> <p>As the input signal increases, Valve stem moves downwards</p>		<p>RA 3</p> <p>As the input signal increases, Valve stem moves upwards</p>	

- SS2R (Rotary Type)

Spring Return	Double Acting	Double Acting
<p>Actuator : RA</p> <p>OUT2 must be plugged</p>	<p>Actuator : RA</p>	<p>Actuator : DA</p>
<p>As the input signal increases, Actuator shaft rotates counter-clockwise</p>	<p>As the input signal increases, Actuator shaft rotates counter-clockwise</p>	<p>As the input signal increases, Actuator shaft rotates clockwise</p>

	Spring Return	Double Acting
Reverse Acting	Out 1 : piped, Out2 : plugged	Out 1 : piped to Actuator port A, Out2 : piped to Actuator port B
Direct Acting	Out 1 : plugged, Out 2 : piped	Out 1 : piped to Actuator port B, Out 2 : piped to Actuator port A

SS2 Front Cover Removed

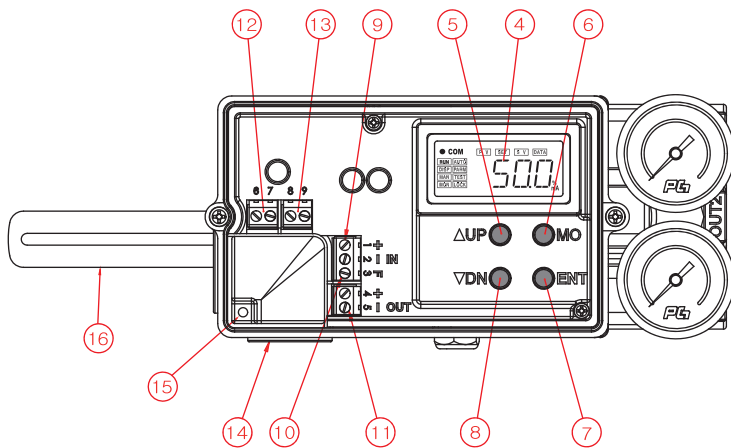

- 1 : Air supply
- 2 : OUT 1
- 3 : OUT 2
- 4 : Display LCD
- 5 : Up key
- 6 : Mode key
- 7 : Enter key
- 8 : Down key
- 9 : Input signal (+, -)
- 10 : Frame ground
- 11 : Output signal (+, -)
- 12 : Alarm limit 1
- 13 : Alarm limit 2
- 14 : Electrical connections
- 15 : Ground
- 16 : Feedback lever

Electrical Connections

- 1 (+) } IN. 4-20mA input signal
- 2 (-) }
- 3 (FG) } Frame Ground
- 4 (+) } OUT. 4-20mA output signal
- 5 (-) }
- 6 (+) } LS1. (Low) Alarm limit 1
- 7 (-) }
- 8 (+) } LS2. (High) Alarm limit 2
- 9 (-) }

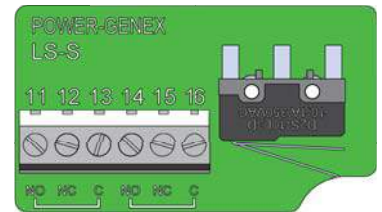
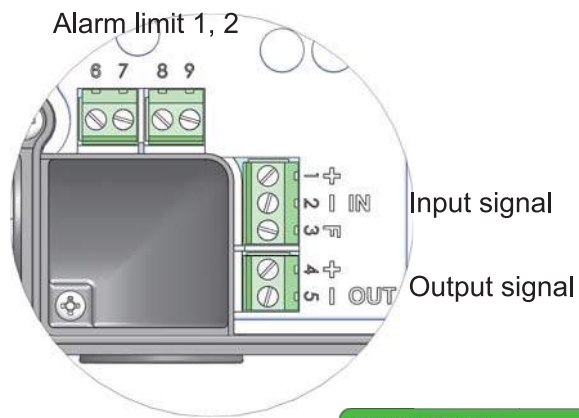

Micro switches 1, 2

Characteristic Curves

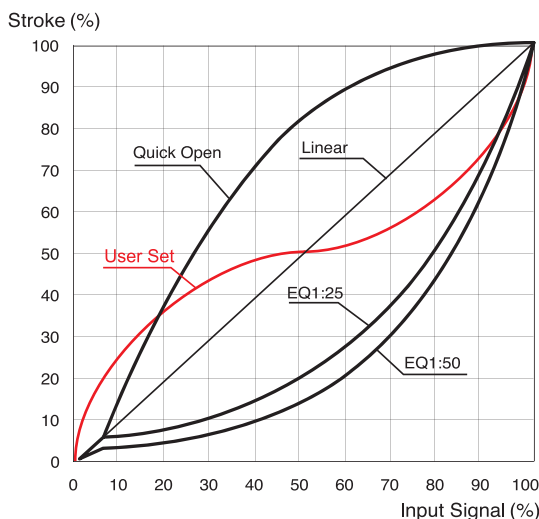

Quick Start and Checking

	Button	Action
Auto - Calibration		Push 5 seconds for auto-calibration
Span	→ or →	Push 5 seconds to change a measured span (Try this option only when a valve doesn't reach a desired position)
Ambient Temp.		Confirm an ambient temperature surrounding this smart valve positioner

Parameters Diagram

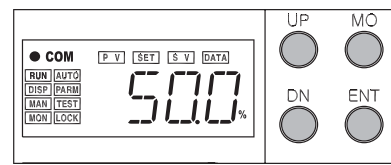
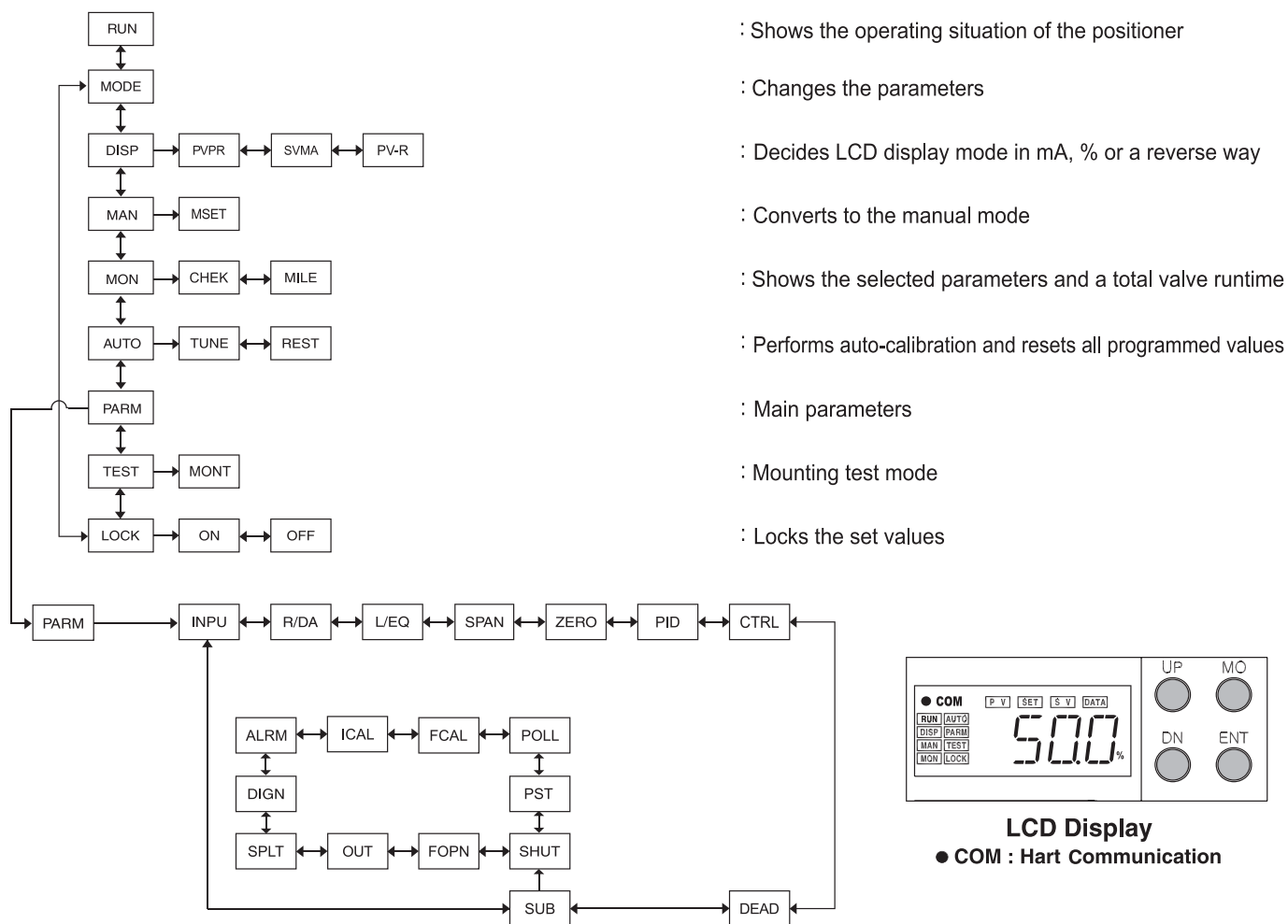

LCD Display

● COM : Hart Communication

Parameter	Description	Fcution	Default
INPU	Input signal	4 ~ 20mA or 20 ~ 4mA	4 ~ 20mA
R/DA	RA/DA	Reverse acting or direct acting	Auto-set
L/EQ	Characteristic	Linear, E.Q.%(1:25 or 1:50), Quick open or User set(17points)	Linear
SPAN	Span adjustment	0 ~ 100%	100%
ZERO	Zero adjustment	0 ~ 99%	0%
PID	P-GN / I-GN / D-GN	Proportional / Integral / Differential gain value	Auto-set
SPED	Response speed	1 ~ 1000	1000
SWST	Slow start	Smooth operation (ON or OFF)	Auto-set
CNLT	Control limit	50 ~ 1250	Auto-set
GCNL	Gap control limit	50 ~ 1250	Auto-set
DEAD	Dead band	0 ~ 9.99%	0.5%
HDGP	D-gain setting for hard mode	D-Gain setting for hard mode	Auto-set
SHUT	Shut-off	0 ~ 9.9%	0.3%
FOPN	Full-open	0 ~ 9.9%	0.3%
OUT	Output signal	4 ~ 20mA or 20 ~ 4mA	4 ~ 20mA
SPLT	Split range	4 ~ 12mA or 12 ~ 20mA	4 ~ 20mA
DIGN	Display place	Movement to one or two decimal places	1
ALAM	Alarm limit low, high	AL1L / AL1H / AL2L / AL2H	0 ~ 10%, 90 ~ 105%
ICAL	IN4M / IN20	Internal match with 4~20mA input signals from a calibrator	Factory setting
FCAL	FB4M / FB20	Internal match with 4~20mA output signals to a calibrator	Factory setting
POLL	Polling address	HART Communication polling address (0 ~ 15)	0
PST	Partial stroke test	Checks a valve status	OFF

Wiring Alarm Limits

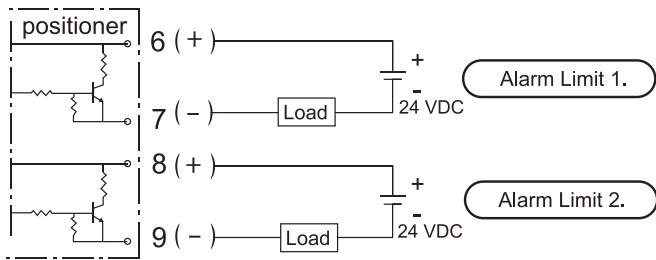

Note that 24 VDC should be supplied for power.

Micro Switches (SPDT)

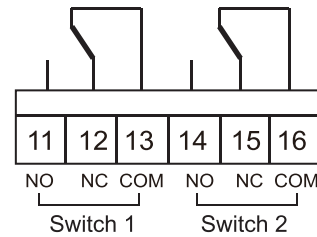

Measuring Output Signal

① With mA loop calibrator

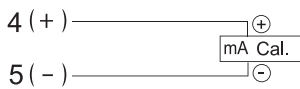

② With multimeter (mA)

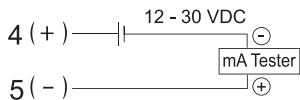

ZERO and SPAN of position feedback are automatically set after auto-calibration process.

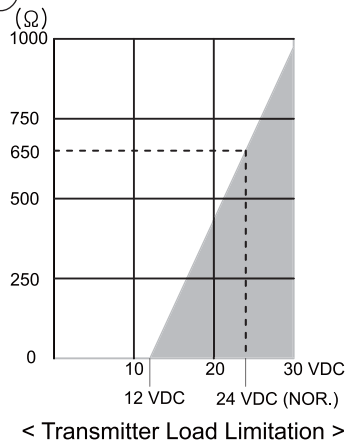

Micro Switches

Type	SPDT
Rating	10.1A @ 250 VAC
Ambient Temperature	-30 ~ +85 °C
Position Transmitter	
Output Signal	4 - 20 mA, 2-wire
Power Supply	12 - 30 VDC
Output Current Limit	30 mA DC
Linearity	1% F.S
Operating Temperature	-40 ~ +80 °C

How to Order

SS2 Actuator Operation — Protection Class — Feedback Lever — Pressure Gauges — By-pass — Position Feedback — Communication — Connection Threads — Mounting Bracket — Feedback Pin Guide Lever Set

Description	Code
Actuator Operation :	L : Linear type R : Rotary type
Protection Class :	I : Intrinsically safe IECEX / ATEX / TR-CU Ex ia IIC T6/T5 K : Intrinsically safe KC - Ex ia IIC T6/T5 W : Weatherproof to IP66
Feedback Lever : - Linear type :	A : Stroke (5~30mm) B : Stroke (5~65mm) C : Stroke (5~130mm) D : Stroke (80~200mm)
- Rotary type :	F : Fork lever N : NAMUR shaft (direct mounting)
Gauge Block :	0 : Not mounted 1 : 6 bar (90 psi) 2 : 10 bar (150 psi)
By-pass :	N : None (standard) Y : Yes (auto/manual screw)

Description	Code
Position Feedback :	N : None O : Position transmitter (4~20mA output signal) L : 2 x alarm limit S : 2 x micro switch (SPDT) M : O + L Q : O + S
Communication :	N : None H : HART P : Profibus PA F : Foundation Fieldbus
Connection Threads : (pneumatic - electrical)	3 : PT(Rc) 1/4 - PF(G) 1/2 4 : NPT 1/4 - NPT 1/2 5 : PT(Rc) 1/4 - M20 x 1.5
Mounting Bracket :	N : None L : IEC 60534-6-1 (for SS2L) R : IEC 60534-6-2 (for SS2R) VDI/VDE 3845
Feedback Pin Guide Lever Set : (only for linear type SS2L)	0 : Not included 1 : Included

Dimensions

- SS2L (Linear Type)

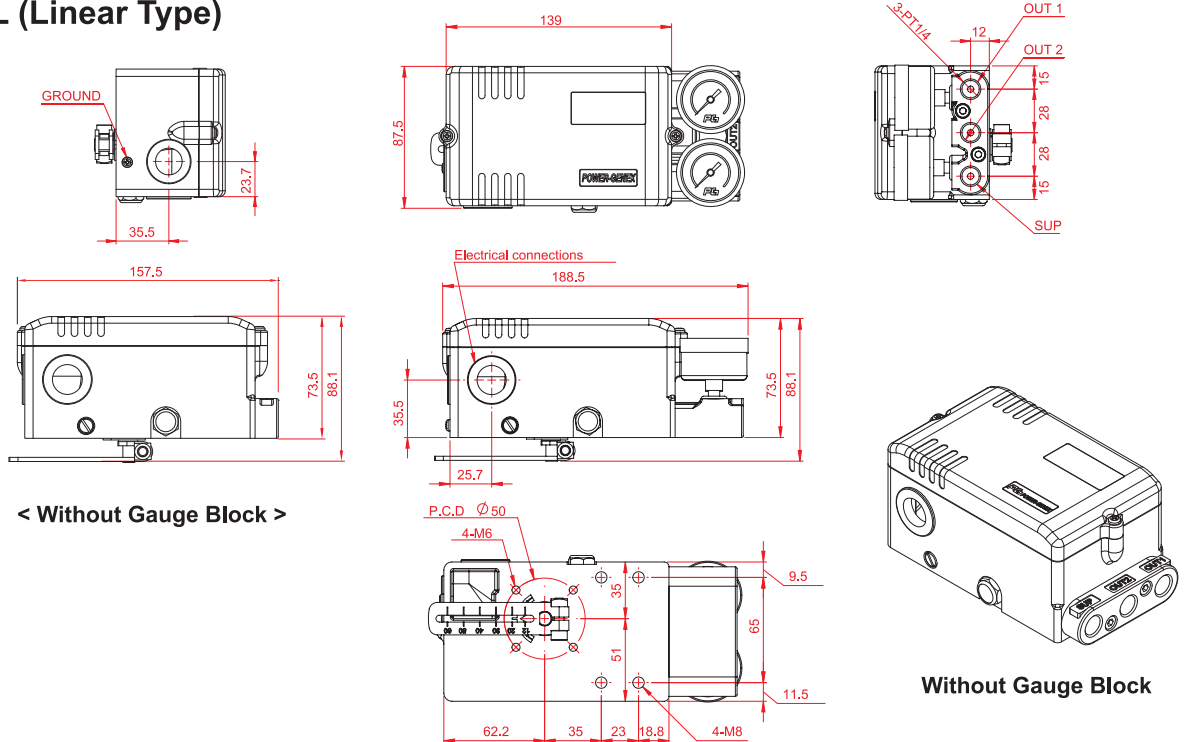

< Without Gauge Block >

Without Gauge Block

- SS2R (Rotary Type)

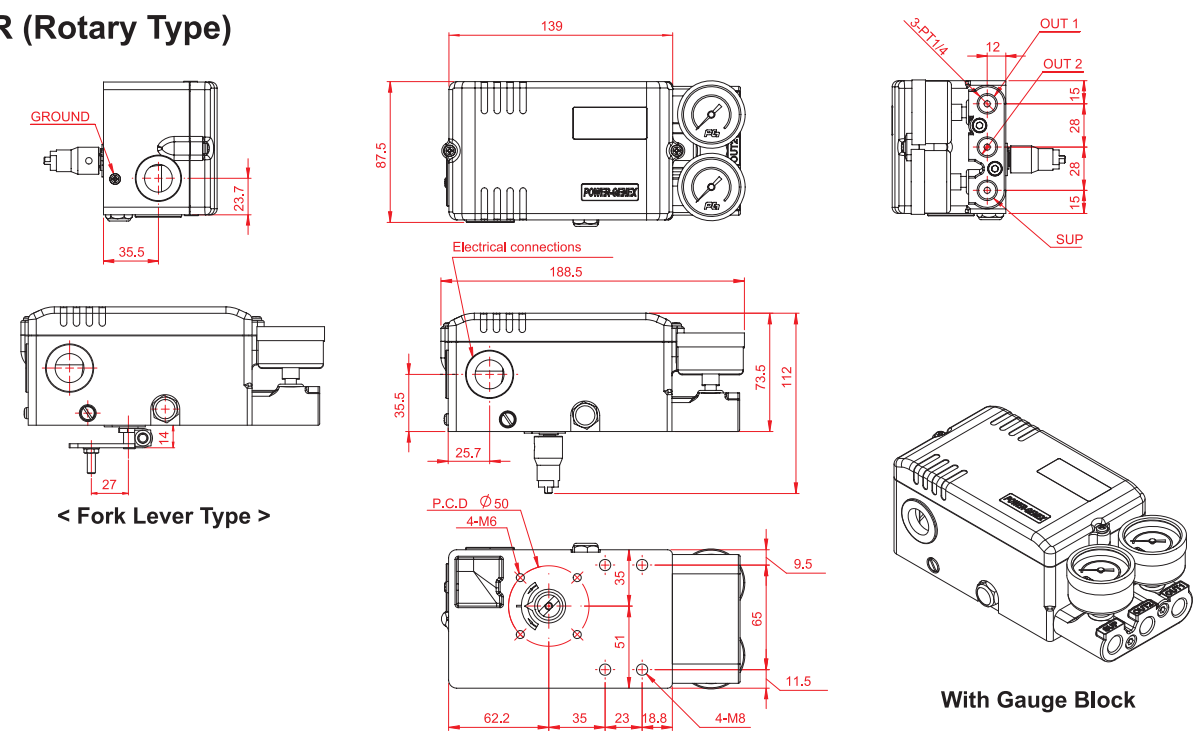

< Fork Lever Type >

With Gauge Block

- SS2 with 2 x SPDT Micro S/W

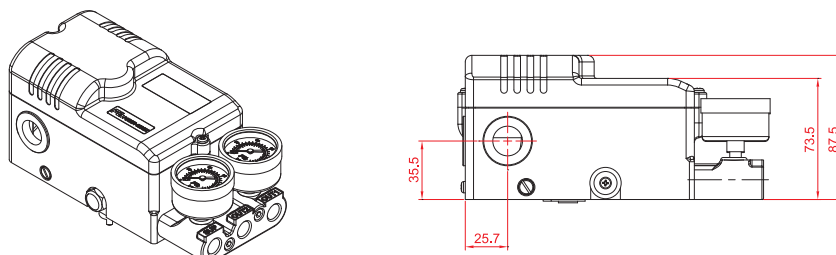

Smart Valve Positioner (remote type)

SS2 Linear / Rotary

How to Order

SS2

Actuator Operation	Protection Class	Feedback Lever	Pressure Gauges	By-pass	Position Feedback	Communi-cation	Connection Threads	Mounting Bracket	Feedback Pin Guide Lever Set	Cable Length
--------------------	------------------	----------------	-----------------	---------	-------------------	----------------	--------------------	------------------	------------------------------	--------------

Description	Code
Cable Length :	3 : 3 m 5 : 5 m 10 : 10 m 15 : 15 m * Other on request

* Please see "How to Order" on page 13 to select more options.

Dimensions

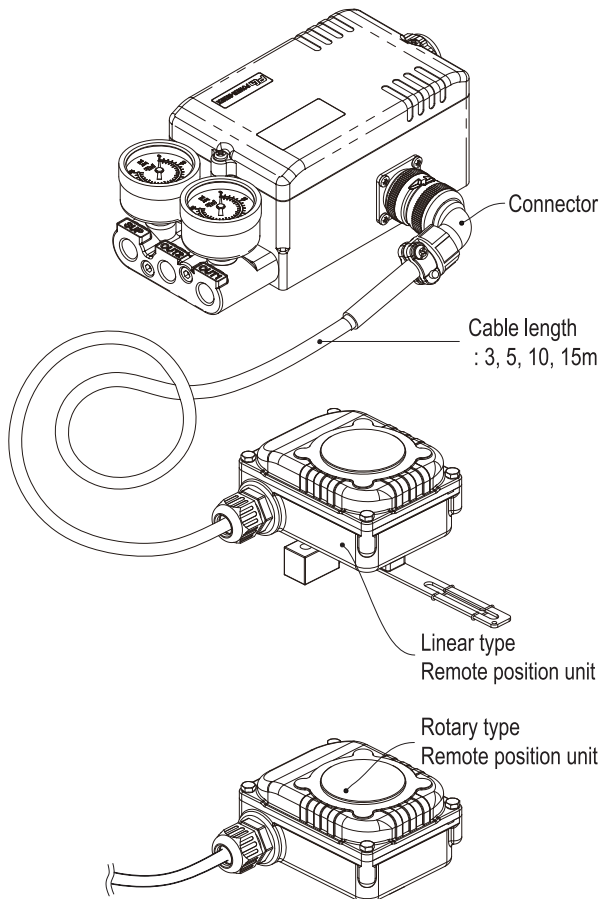

< Linear Type Remote Position Unit >

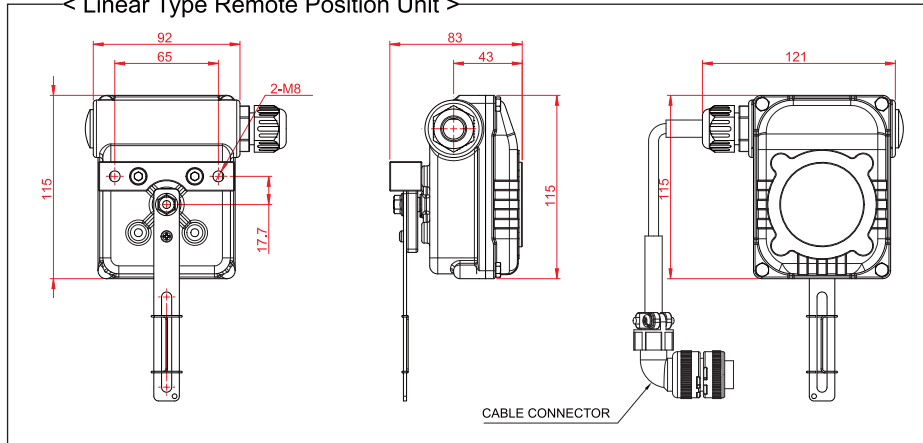

< Rotary Type Remote Position Unit >

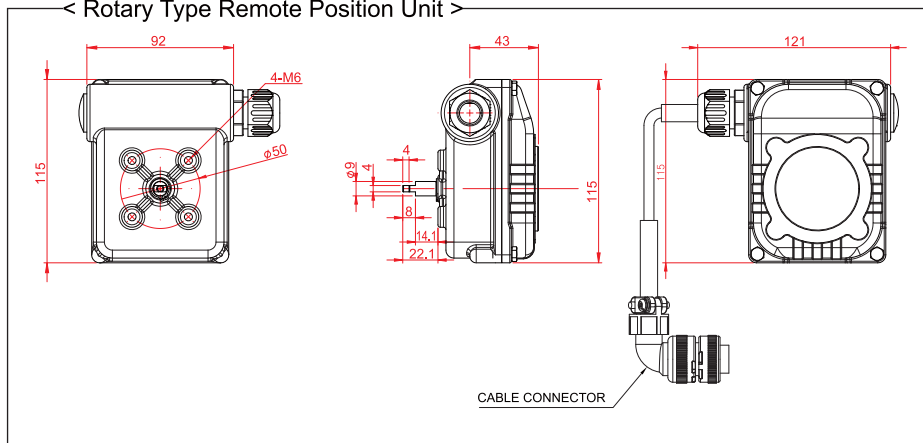

Specifications



< SS2SL & SS2SR >



Communication	Without	HART	Profibus-PA	Fieldbus
Input Signal	4 - 20 mA @ 24 VDC		9 - 32 VDC	
Min. / Max. Current	3.6 mA / 50 mA		-	
Current Consumption	-		15mA	16mA
Voltage Drop (Resistance)	8.7 VDC(435Ω)	9.4 VDC(470Ω)		
Stroke / Angle	Linear type : 5 - 130 mm * Rotary type : 25 - 120°			
Air Supply Pressure	1.4 - 7.0 bar (20 - 100 psi)			
Output Pressure Range	0 - 100% of supply air pressure			
Air Capacity	80 ℓ/min = 4.8 N ^m /h = 2.8 scfm (Sup = 1.4 bar) 233 ℓ/min = 14 N ^m /h = 8.2 scfm (Sup = 6 bar)			
Air Consumption	2.8 ℓ/min = 0.17 N ^m /h = 0.1 scfm (Sup = 1.4 ~ 6 bar)			
Characteristic	Linearity < ±0.3% F.S Hysteresis < 0.2% F.S		Sensitivity < 0.2% F.S Repeatability < 0.2% F.S	
Performance Characteristic	Linear, EQ %, Quick open, User set (17 points)			
LCD Indication	4-digit LCD indicator			
Adjustable Speed	1 - 1000 (lowest 1, highest 1000)			
Scan Time	2ms			
Shut-off Value	Range 0 - 10% of position signal			
Valve Action	Direct action(DA) / Reverse action(RA)			
Operating Temperature	- 30 ~ +80 °C (- 22 ~ +176 °F) **			
Pneumatic Connections	NPT 1/4 (other on request)			
Electrical Connections	NPT 1/2 (other on request)			
Protection Class	IP66, Intrinsically safe (IECEx / ATEX / KC Exia IIC T6/T5)			
Body Material	Stainless steel 316			
Weight	3.8 kg (without bracket)			

How to Order

* Up to 200mm on request ** -40°C on request

SS2S Actuator Operation Protection Class Feedback Lever Pressure Gauges By-pass Position Feedback Communication Connection Threads Mounting Bracket Feedback Pin Guide Lever Set

Description	Code
Actuator Operation :	L : Linear type R : Rotary type
Protection Class :	I : Intrinsically safe IECEx / ATEX / TR-CU Ex ia IIC T6/T5 K : Intrinsically safe KC - Ex ia IIC T6/T5 W : Weatherproof to IP66
Feedback Lever :	
- Linear type :	A : Stroke (5~30mm) B : Stroke (5~65mm) C : Stroke (5~130mm) D : Stroke (80~200mm)
- Rotary type :	F : Fork lever N : NAMUR shaft (direct mounting)
Gauge Block :	0 : Not mounted 1 : 6 bar (90 psi) 2 : 10 bar (150 psi)
By-pass :	N : None Y : Yes (auto/manual screw)

Description	Code
Position Feedback :	N : None O : Position transmitter (4~20mA output signal) L : 2 x alarm limit S : 2 x micro switch (SPDT) M : O + L Q : O + S
Communication :	N : None H : HART P : Profibus PA F : Fieldbus Foundation
Connection Threads : (pneumatic - electrical)	4 : NPT 1/4 - NPT 1/2
Mounting Bracket :	N : None L : IEC 60534-6-1 (for SS2SL) R : IEC 60534-6-2 (for SS2SR) VDI/VE 3845
Feedback Pin Guide Lever Set : (only for linear type SS2SL)	0 : Not included 1 : Included

Smart Valve Positioner

(Linear Sensor Positioner for Cylinder)

SS2 Linear / Rotary



< Cylinder type >



< Angle Seat Valve type >



Specifications

Communication	Without	HART	Profibus-PA	Fieldbus
Input Signal	4 - 20 mA @ 24 VDC		9 - 32 VDC	
Min. / Max. Current	3.6 mA / 50 mA		-	
Current Consumption	-		15mA	16mA
Voltage Drop (Resistance)	8.9 VDC(445Ω)	9.4 VDC(470Ω)		
Stroke	Up to 1000 mm			
Air Supply Pressure	1.4 - 7.0 bar (20 - 100 psi)			
Output Pressure Range	0 - 100% of supply air pressure			
Air Capacity	80 l/min = 4.8 N ^m /h = 2.8 scfm (Sup = 1.4 bar) 233 l/min = 14 N ^m /h = 8.2 scfm (Sup = 6 bar)			
Air Consumption	2 l/min = 0.12 N ^m /h = 0.07 scfm (Sup = 1.4 ~ 6 bar)			
Characteristic	Linearity $\pm 0.3\%$ F.S Hysteresis $< 0.2\%$ F.S		Sensitivity $< 0.2\%$ F.S Repeatability $< 0.2\%$ F.S	
Performance Characteristic	Linear, EQ %, Quick open, User set (17 points)			
LCD Indication	4-digit LCD indicator			
Adjustable Speed	1 - 1000 (lowest 1, highest 1000)			
Scan Time	2ms			
Shut-off Value	Range 0 - 10% of position signal			
Valve Action	Direct action(DA) / Reverse action(RA)			
Operating Temperature	- 30 ~ +80°C (- 22 ~ +176 °F) *			
Pneumatic Connections	PT(Rc) 1/4, NPT 1/4			
Electrical Connections	2 x PF(G) 1/2, NPT 1/2, M20 x 1.5			
Protection Class	IP66, Intrinsically safe (IECEX / ATEX / KC Ex ia IIC T6/T5)			
Body Material	Aluminum die-cast / power-painted			
Weight	1.6 kg (without bracket & sensor)			

* - 40°C on request

How to Order

SS2C — Protection Class — Cylinder Stroke — Pressure Gauges — By-pass — Position Feedback — Communication — Connection Threads — Mounting Bracket — Cable Length

Description	Code
Protection Class :	I : Intrinsically safe IECEX / ATEX / TR-CU Ex ia IIC T6/T5 K : Intrinsically safe KC - Ex ia IIC T6/T5 W : Weatherproof to IP66
Cylinder Stroke :	A : Cylinder stroke 10 ~ 30mm B : Cylinder stroke 30 ~ 80mm C : Cylinder stroke 80 ~ 125mm D : Cylinder stroke 125 ~ 165mm E : Cylinder stroke 165 ~ 260mm F : Cylinder stroke 260 ~ 350mm x : Other on request
Gauge Block :	0 : Not mounted 1 : 6 bar (90 psi) 2 : 10 bar (150 psi)
By-pass :	N : None Y : Yes (auto/manual screw)

Description	Code
Position Feedback :	N : None O : Position transmitter (4~20mA output signal) L : 2 x alarm limit M : O + L
Communication :	N : None H : HART P : Profibus PA F : Foundation Fieldbus
Connection Threads : (pneumatic - electrical)	3 : PT(Rc) 1/4 - PF 1/2 4 : NPT 1/4 - NPT 1/2 5 : PT(Rc) 1/4 - M20 x 1.5
Mounting Bracket :	N : None Actuator Model NO.
Cable Length :	Standard, 3, 5, 10, 15m Other : On request

Dimensions

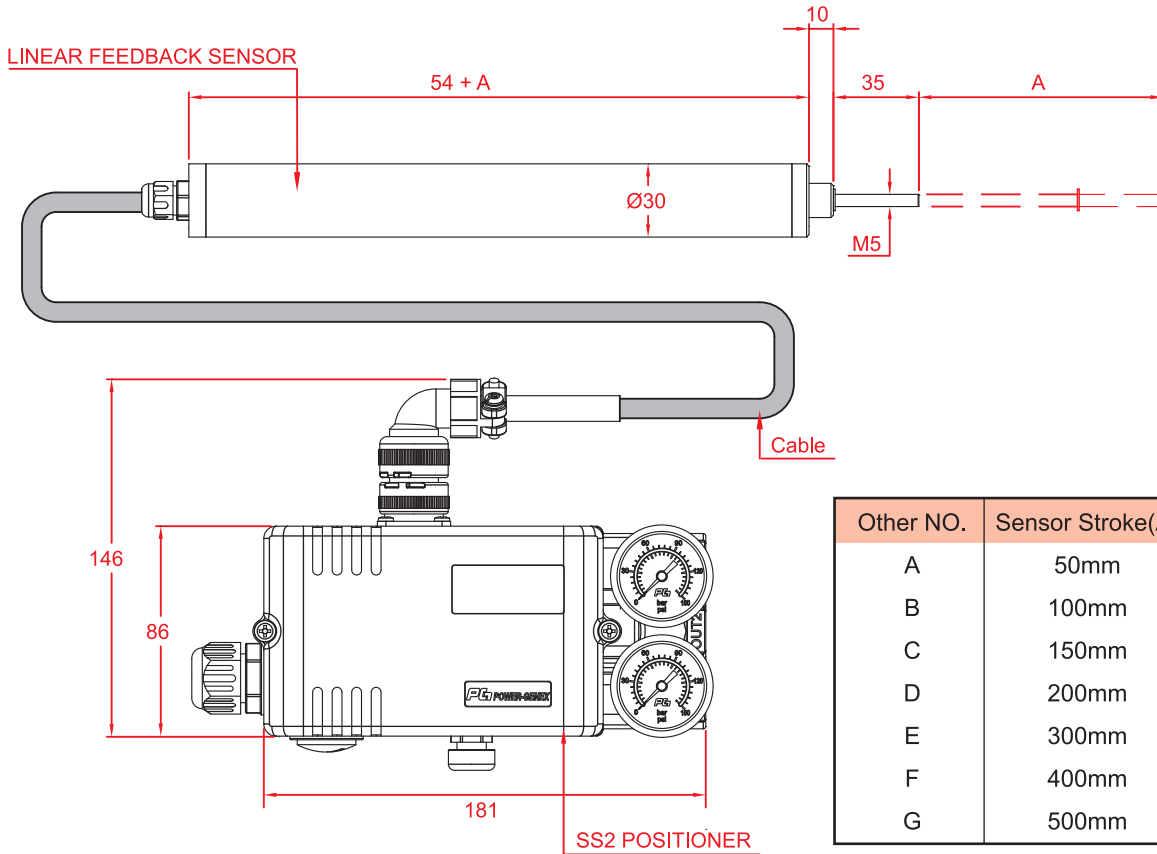

Other NO.	Sensor Stroke(A)	Stroke
A	50mm	10 ~ 30mm
B	100mm	30 ~ 80mm
C	150mm	80 ~ 125mm
D	200mm	125 ~ 165mm
E	300mm	165 ~ 260mm
F	400mm	260 ~ 350mm
G	500mm	350 ~ 440mm

Applications

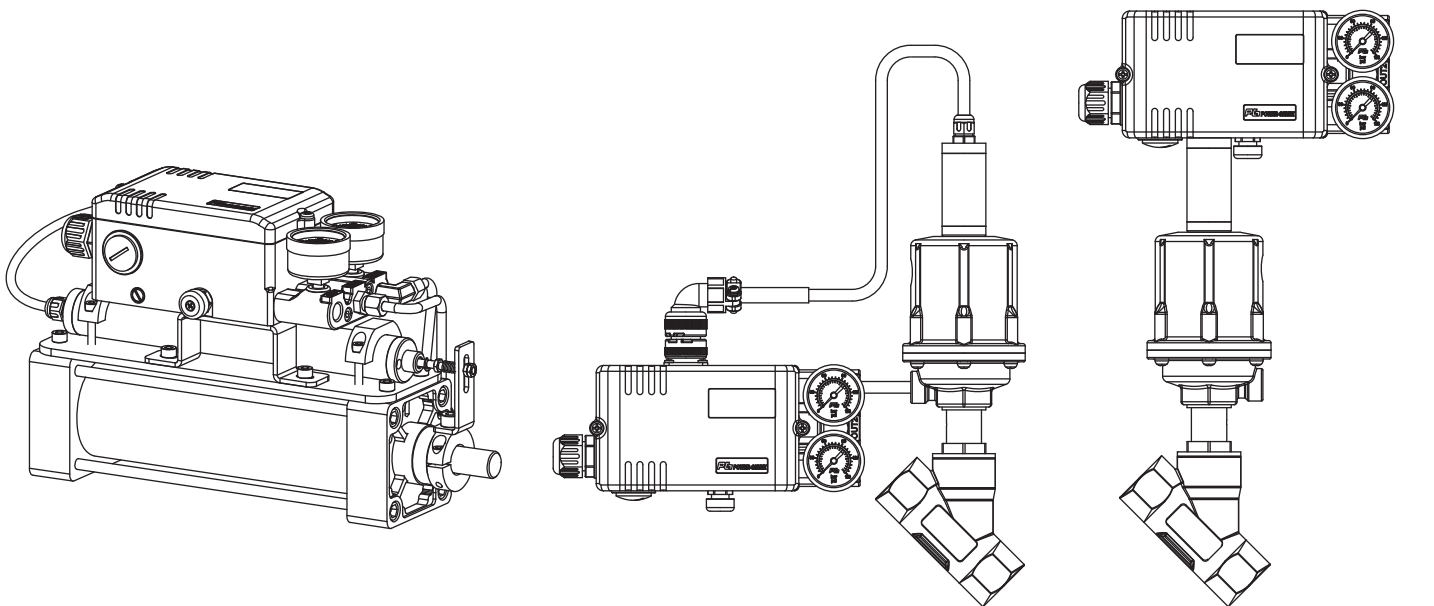

< Cylinder Mounting >

< Remote Mounting >

< Angle Seat Valve Mounting >

Sturdy explosion proof housing and smart performance with innovative and ever-strong coil drive even under harsh working environments

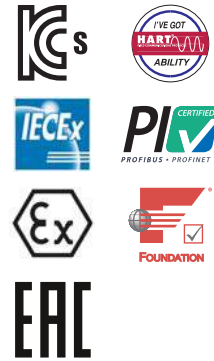

Features

- ▶ Flameproof IECEx / ATEX / TR-CU / KC Ex d IIC T6
- ▶ Easy and quick auto-calibration
- ▶ Detecting RA (reverse acting) or DA (direct acting) automatically regardless of wrong air connections
- ▶ Available to use for single or double acting without any special adjustments
- ▶ Compact design allowing to be installed on small actuators
- ▶ Providing error messages against performance failures
- ▶ Possible to test the actuator with any fixed signal under a test mode
- ▶ Programmable characteristic curve with 17 points
- ▶ Wide operating temperature range -30 ~ +75 °C
- ▶ Improved control of high-friction globe and ball valves by eliminating an overshoot and a hunting
- ▶ Low air consumption
- ▶ Providing a mounting bracket to meet IEC 60534-6-1 for linear valves
- ▶ Supporting a NAMUR mounting pattern IEC 60534-6-2 (VDI/VDE 3845) and providing a multi-size mounting bracket for rotary valves

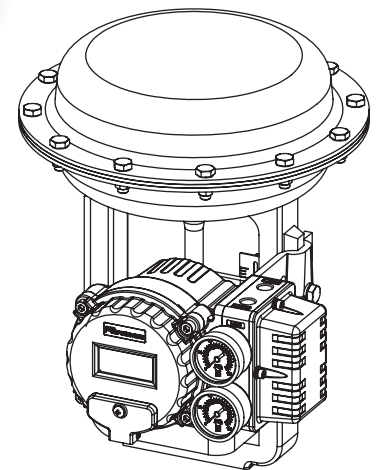

- SS3L (Linear Type)

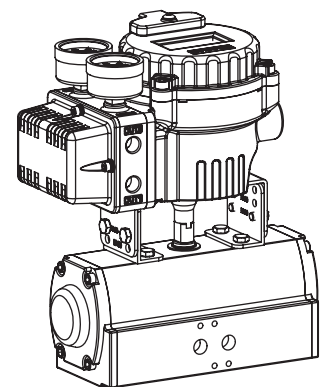

- SS3R (Rotary Type)

Options

- ▶ Output position transmitter (4 - 20 mA)
- ▶ 2 x alarm limit
- ▶ Low temperature (-40°C)
- ▶ HART communication
- ▶ Profibus PA communication
- ▶ Foundation Fieldbus communication

Specifications

Communication	Without	HART	Profibus - PA	Foundation Fieldbus
Input Signal / Bus voltage	4 - 20 mA @ 24 VDC		9 - 32 VDC	
Min. / Max. Current	3.6 mA / 50 mA		-	
Current Consumption	-		15mA	16mA
Voltage Drop (Resistance)	8.7 VDC(435Ω)	9.4 VDC(470Ω)	-	
Stroke / Angle	Linear type : 5 - 130 mm * Rotary type : 25 - 120°			
Air Supply Pressure	1.4 - 7.0 bar (20 - 100 psi), filtered, compressed dry and non-oiled to meet Class 3 of ISO 8573-1			
Output Pressure Range	0 - 100% of supply air pressure			
Air Capacity	80 ℓ/min = 4.8 N ^m /h = 2.8 scfm (Sup = 1.4 bar) 233 ℓ/min = 14 N ^m /h = 8.2 scfm (Sup = 6 bar)			
Air Consumption	2.8 ℓ/min = 0.17 N ^m /h = 0.1 scfm (Sup = 1.4 ~ 6 bar)			
Characteristic	Linearity < ±0.3% F.S Hysteresis < 0.2% F.S		Sensitivity < 0.2% F.S Repeatability < 0.2% F.S	
Performance Characteristic	Linear, EQ %, Quick open, User set (17 points)			
LCD Indication	4-digit LCD indicator			
Adjustable Speed	1 - 1000 (lowest 1, highest 1000)			
Scan Time	2ms			
Shut-off Value	Range 0 - 10% of position signal			
Valve Action	direct action (DA) / reverse action (RA)			
Operating Temperature	- 30 ~ +75°C (- 22 ~ +167 °F) **			
Pneumatic Connections	PT(Rc) 1/4 or NPT 1/4			
Electrical Connections	2 x PF(G) 1/2 , NPT 1/2 , M20 x 1.5			
Protection Class	Flameproof IECEx / ATEX / KC Ex d IIC T6, IP66			
Body Material	Aluminum die-cast / powder-painted			
Weight	2.8 kg			

* Up to 200mm on request ** -40°C on request

Principle of Operation

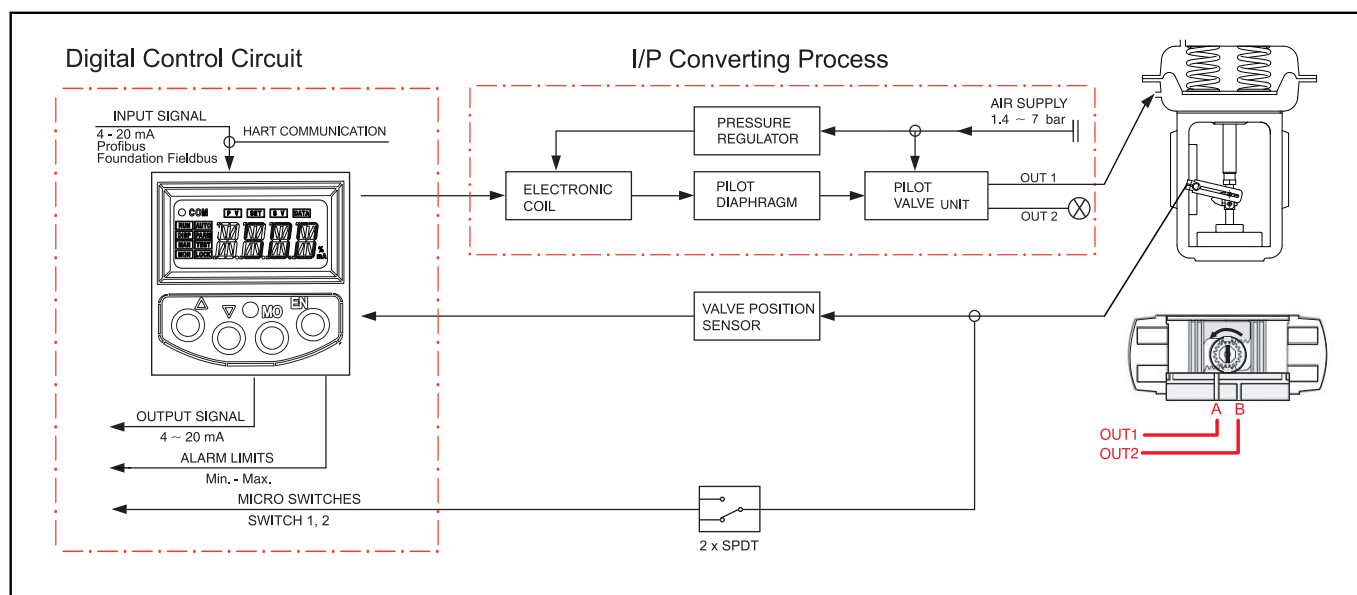

If 4-20 mA input signal(or Bus communication signal) is supplied, the micro processor compares input signal with position feedback and sends control signal to the I/P converting module. Pneumatic signal from the I/P converting module operates the valve and the valve stays at the desired position.

Mounting to Linear Actuator

- SS3L (Linear Type)

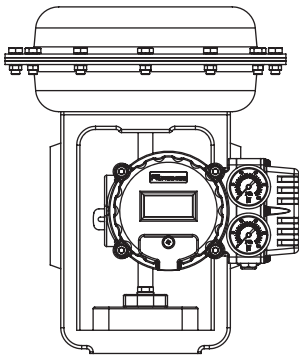

< Front View >

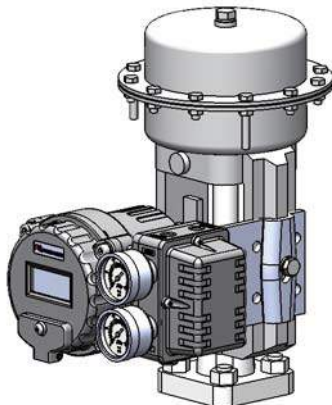

< Side View >

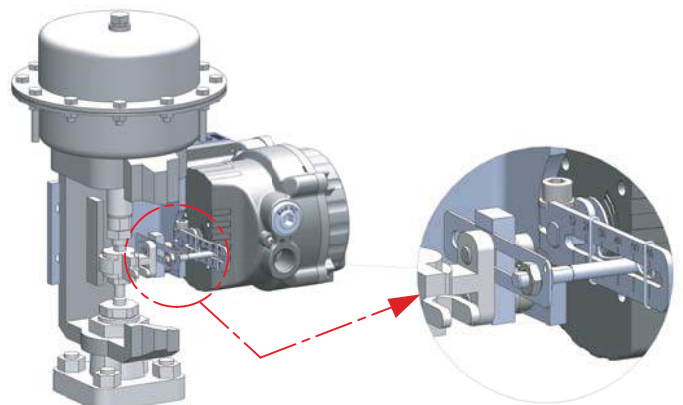

< Feedback Lever Connection >

"A" Type

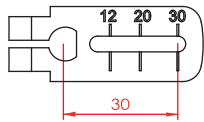

"B" Type

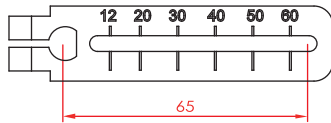

"C" Type

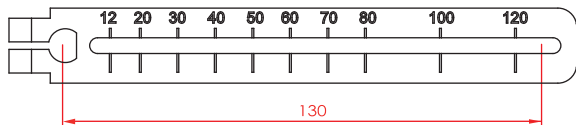

Feedback Lever

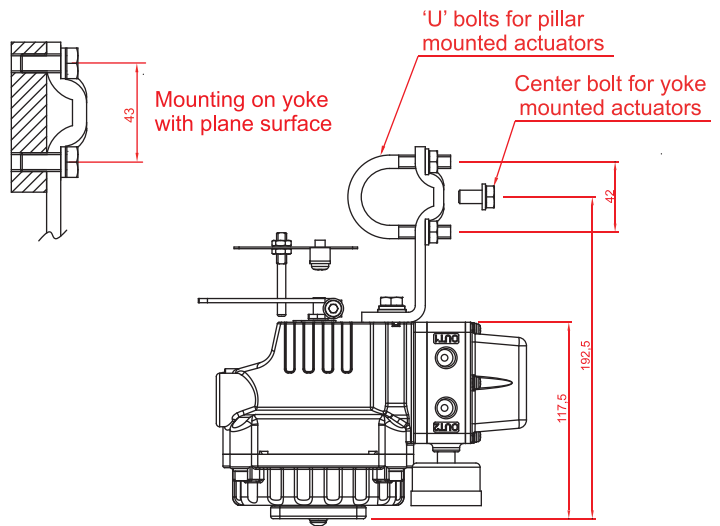

Mounting to linear actuators to IEC 60534 6-1

Mounting to Rotary Actuator

- SS3R (Rotary Type)

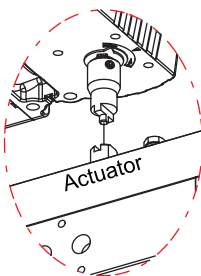
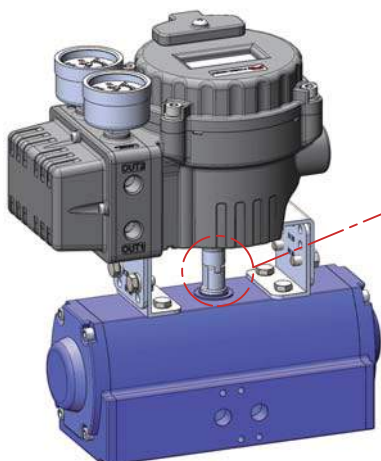

NAMUR Type Mounting
(VDI/VDE 3845,
IEC 60534-6-2)

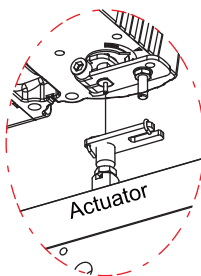

Fork Lever Type Mounting

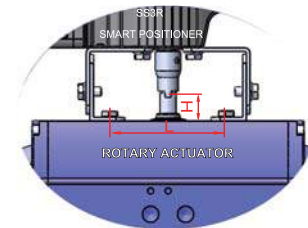

Size Variation of Multi-Size Bracket

- 1) 80 x 30 x 20 (H) , 4) 130 x 30 x 20 (H)
- 2) 80 x 30 x 30 (H) , 5) 130 x 30 x 30 (H)
- 3) 80 x 30 x 50 (H) , 6) 130 x 30 x 50 (H)

H : Rotary Actuator Shaft Height
L : Length (80 or 130mm)

Air Connections

- SS3L (Linear Type)

Direct Acting (DA)		Reverse Acting (RA)	
<p>DA 1</p> <p>As the input signal increases, Valve stem moves downwards Actuator : DA</p>	<p>OUT2 must be plugged</p>	<p>RA 1</p> <p>As the input signal increases, Valve stem moves upwards Actuator : RA</p>	<p>OUT2 must be plugged</p>
<p>DA 2</p> <p>As the input signal increases, Valve stem moves downwards Actuator : DA</p>	<p>OUT1 must be plugged</p>	<p>RA 2</p> <p>As the input signal increases, Valve stem moves upwards Actuator : RA</p>	<p>OUT1 must be plugged</p>
<p>DA 3</p> <p>As the input signal increases, Valve stem moves downwards</p>		<p>RA 3</p> <p>As the input signal increases, Valve stem moves upwards</p>	

- SS3R (Rotary Type)

Spring Return	Double Acting	Double Acting
<p>Actuator : RA</p> <p>OUT2 must be plugged</p>	<p>Actuator : RA</p>	<p>Actuator : DA</p>
<p>As the input signal increases, Actuator shaft rotates counter-clockwise</p>	<p>As the input signal increases, Actuator shaft rotates counter-clockwise</p>	<p>As the input signal increases, Actuator shaft rotates clockwise</p>

	Spring Return	Double Acting
Reverse Acting	Out 1 : piped, Out 2 : plugged	Out 1 : piped to Actuator port A, Out 2 : piped to Actuator port B
Direct Acting	Out 1 : plugged, Out 2 : piped	Out 1 : piped to Actuator port B, Out 2 : piped to Actuator port A

SS3 Front Cover Removed

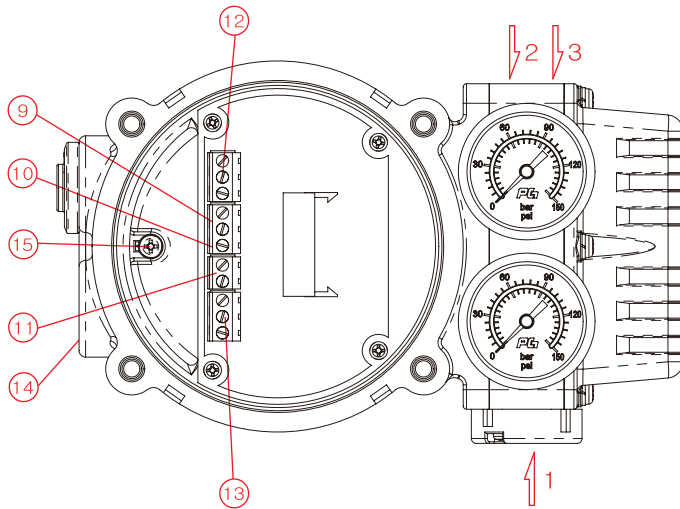

SS3 Front Cover

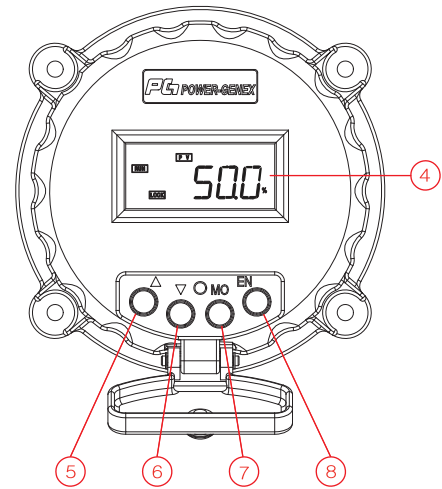

- | | | | |
|-----------------|---------------|---------------------------|-----------------------------|
| 1 : Air supply | 5 : Up key | 9 : Input signal (+, -) | 13 : Alarm limit |
| 2 : OUT 1 | 6 : Down key | 10 : Frame ground | 14 : Electrical connections |
| 3 : OUT 2 | 7 : Mode key | 11 : Output signal (+, -) | 15 : Ground |
| 4 : Display LCD | 8 : Enter key | 12 : Alarm limit | 16 : Feedback lever |

Electrical Connections

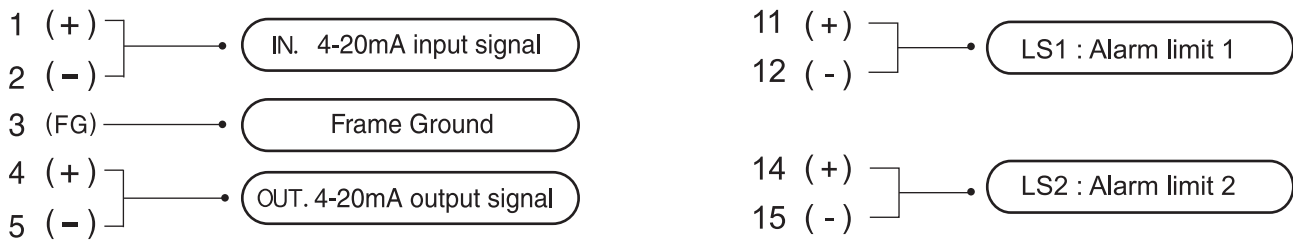

Characteristic Curves

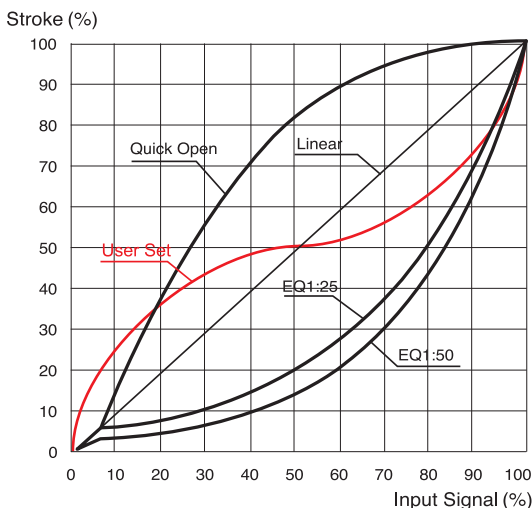

Quick Start and Checking

	Button	Action
Auto - Calibration	MO	Push 5 seconds for auto-calibration
Span	VDN → ENT VDN or ΔUP ENT → MO	Push VDN 5 seconds to change a measured span (Try this option only when a valve doesn't reach a desired position)
Ambient Temp.	ENT	Confirm an ambient temperature surrounding this smart valve positioner

Parameters Diagram

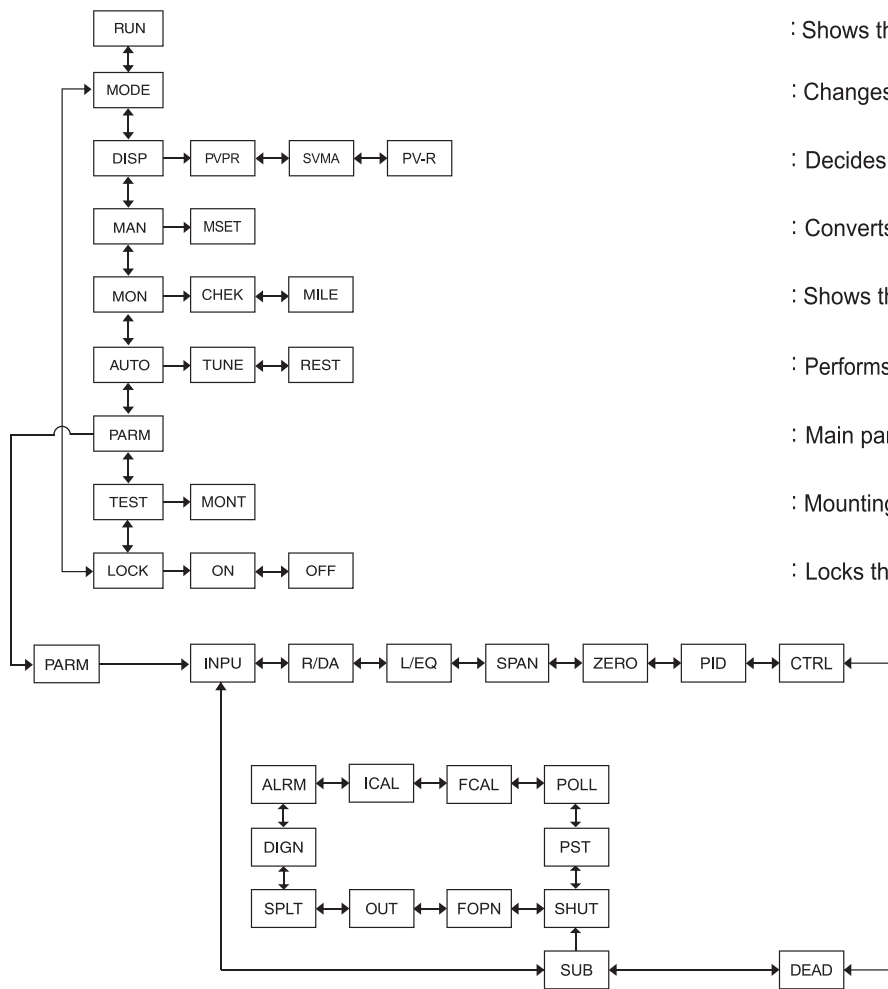

- : Shows the operating situation of the positioner
- : Changes the parameters
- : Decides LCD display mode in mA, % or a reverse way
- : Converts to the manual mode
- : Shows the selected parameters and a total valve runtime
- : Performs auto-calibration and resets all programmed values
- : Main parameters
- : Mounting test mode
- : Locks the set values

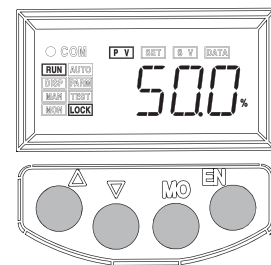

LCD Display

● COM : Hart Communication

Parameter	Description	Fcution	Default
INPU	Input signal	4 ~ 20mA or 20 ~ 4mA	4 ~ 20mA
R/DA	RA/DA	Reverse acting or direct acting	Auto-set
L/EQ	Characteristic	Linear, E.Q.%(1:25 or 1:50), Quick open or User set(17points)	Linear
SPAN	Span adjustment	0 ~ 100%	100%
ZERO	Zero adjustment	0 ~ 99%	0%
PID	P-GN / I-GN / D-GN	Proportional / Integral / Differential gain value	Auto-set
SPED	Response speed	1 ~ 1000	1000
SWST	Slow start	Smooth operation (ON or OFF)	Auto-set
CNLT	Control limit	50 ~ 1250	Auto-set
GCNL	Gap control limit	50 ~ 1250	Auto-set
DEAD	Dead band	0 ~ 9.99%	0.5%
FDGN	D-gain setting for hard mode	D-Gain setting for hard mode	Auto-set
C/MD	NORM / HARD / SMAL	Standard actuator, strong valve packing friction, small actuator	NORM
SHUT	Shut-off	0 ~ 9.9%	0.3%
FOPN	Full-open	0 ~ 9.9%	0.3%
OUT	Output signal	4 ~ 20mA or 20 ~ 4mA	4 ~ 20mA
SPLT	Split range	4 ~ 12mA or 12 ~ 20mA	4 ~ 20mA
DIGN	Display place	Movement to one or two decimal places	1
ALAM	Alarm limit low, high	AL1L / AL1H / AL2L / AL2H	0 ~ 10%, 90 ~ 105%
ICAL	IN4M / IN20	Internal match with 4~20mA input signals from a calibrator	Factory setting
FCAL	FB4M / FB20	Internal match with 4~20mA output signals to a calibrator	Factory setting
POLL	Polling address	HART Communication polling address (0 ~ 15)	0
PST	Partial stroke test	Checks a valve status	OFF

Wiring Alarm Limits

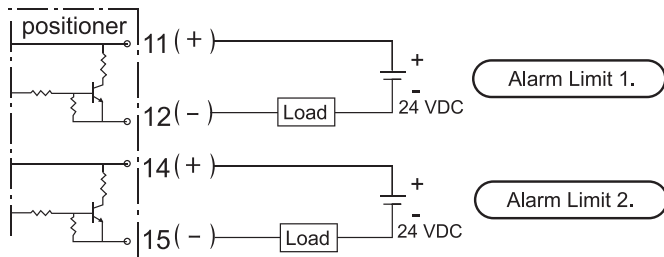

Note that 24 VDC should be supplied for power.

Micro Switches (SPDT)

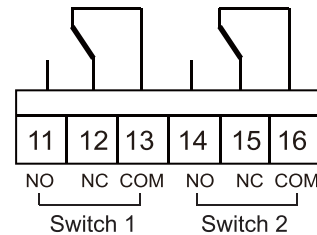

Measuring Output Signal

① With mA loop calibrator

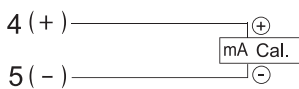

② With multimeter (mA)

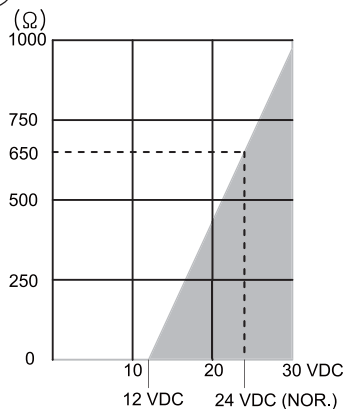
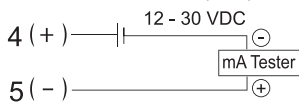

< Transmitter Load Limitations >

Position Transmitter

Output Signal	4 - 20 mA, 2-wire
Power Supply	12 - 30 VDC
Output Current Limit	30 mA DC
Linearity	1% F.S
Operating Temp.	-30 ~ +80 °C

How to Order

SS3

Actuator Operation	Protection Class	Feedback Lever	Pressure Gauges	By-pass	Position Feedback	Communication	Connection Threads	Mounting Bracket	Feedback Pin Guide Lever Set
--------------------	------------------	----------------	-----------------	---------	-------------------	---------------	--------------------	------------------	------------------------------

Description	Code
Actuator Operation :	L : Linear type R : Rotary type
Protection Class :	F : Flameproof IECEX / ATEX / TR-CU Ex d IIC T6 K : Flameproof KC - Ex d IIC T6
Feedback Lever :	
- Linear type :	A : Stroke (5~30mm) B : Stroke (5~65mm) C : Stroke (5~130mm) D : Stroke (80~200mm)
- Rotary type :	F : Fork lever N : NAMUR shaft (direct mounting)
Gauge Block :	0 : Not mounted 1 : 6 bar (90 psi) 2 : 10 bar (150 psi)
By-pass :	N : None (standard) Y : Yes (auto/manual screw)

Description	Code
Position Feedback :	N : None O : Position transmitter (4~20mA output signal) L : 2 x alarm limit S : 2 x SPDT (only for rotary type) M : O + L Q : O + S (only for rotary type)
Communication :	N : None H : HART P : Profibus PA F : Foundation Fieldbus
Connection Threads : (pneumatic - electrical)	3 : PT(Rc) 1/4 - PF(G) 1/2 4 : NPT 1/4 - NPT 1/2 5 : PT(Rc) 1/4 - M20 x 1.5
Mounting Bracket :	N : None L : IEC 60534-6-1 (for SS3L) R : IEC 60534-6-2 (for SS3R) VDI/VDE 3845
Feedback Pin Guide Lever Set : (only for linear type SS3L)	0 : Not included 1 : Included

Dimensions

- SS3L (Linear Type)

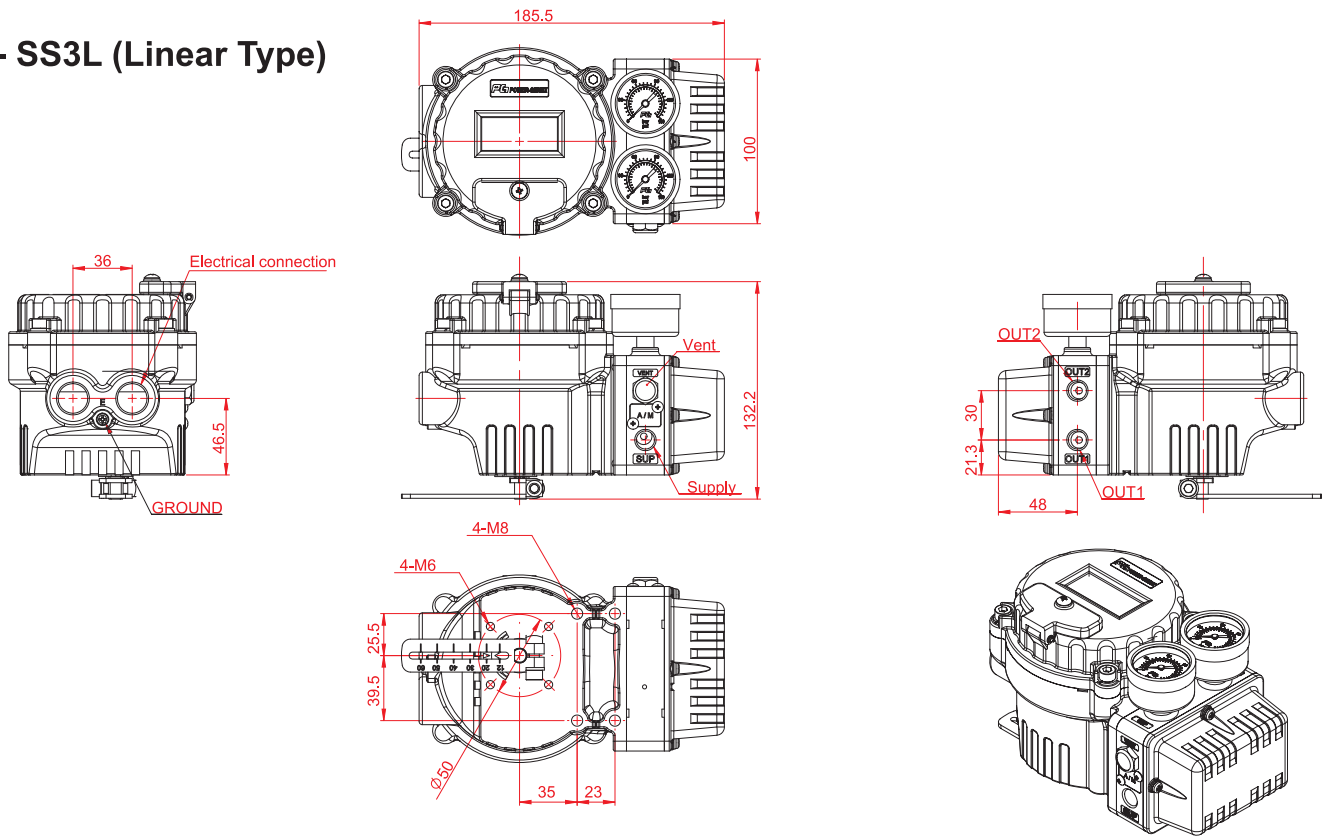

- SS3R (Rotary Type)

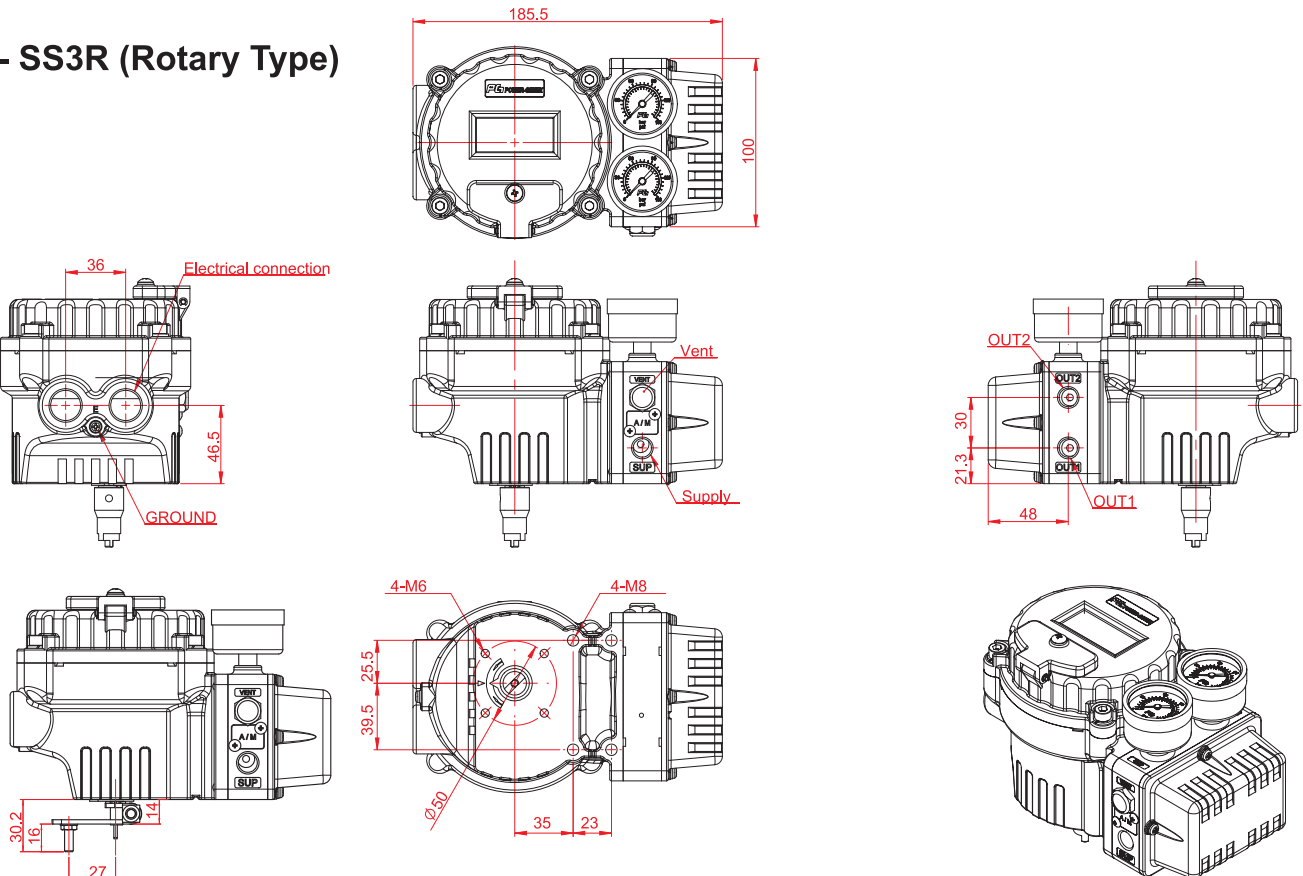

< Fork Lever Type >

Smart Valve Positioner

(stainless steel 316 body)

SS3S Linear / Rotary

Specifications

Communication	Without	HART	Profibus-PA	Fieldbus
Input Signal	4 - 20 mA @ 24 VDC		9 - 32 VDC	
Min. / Max. Current	3.6 mA / 50 mA		-	
Current Consumption	-		15mA	16mA
Voltage Drop (Resistance)	8.7 VDC(435Ω)	9.4 VDC(470Ω)		
Stroke / Angle	Linear type : 5 - 130 mm * Rotary type : 25 - 120°			
Air Supply Pressure	1.4 - 7.0 bar (20 - 100 psi)			
Output Pressure Range	0 - 100% of supply air pressure			
Air Capacity	80 ℓ/min = 4.8 N ^m /h = 2.8 scfm (Sup = 1.4 bar) 233 ℓ/min = 14 N ^m /h = 8.2 scfm (Sup = 6 bar)			
Air Consumption	2.8 ℓ/min = 0.17 N ^m /h = 0.1 scfm (Sup = 1.4 ~ 6 bar)			
Characteristic	Linearity < ±0.3% F.S Hysteresis < 0.2% F.S		Sensitivity < 0.2% F.S Repeatability < 0.2% F.S	
Performance Characteristic	Linear, EQ %, Quick open, User set (17 points)			
LCD Indication	4-digit LCD indicator			
Adjustable Speed	1 - 1000 (lowest 1, highest 1000)			
Scan Time	2ms			
Shut-off Value	Range 0 - 10% of position signal			
Valve Action	Direct action(DA) / Reverse action(RA)			
Operating Temperature	- 30 ~ +75 °C (- 22 ~ +167 °F) **			
Pneumatic Connections	NPT 1/4 (other on request)			
Electrical Connections	NPT 1/2 (other on request)			
Protection Class	Flameproof (IECEX / ATEX / KC Ex d IIC T6)			
Body Material	Stainless steel 316			
Weight	6.5 kg (without bracket)			



< SS3SL & SS3SR >



How to Order

* Up to 200mm on request ** -40°C on request

SS3S Actuator Operation Protection Class Feedback Lever Pressure Gauges By-pass Position Feedback Communication Connection Threads Mounting Bracket Feedback Pin Guide Lever Set

Description	Code
Actuator Operation :	L : Linear type R : Rotary type
Protection Class :	F : Flameproof IECEX / ATEX / TR-CU Ex d IIC T6 K : Flameproof KC - Ex d IIC T6
Feedback Lever :	
- Linear type :	A : Stroke (5~30mm) B : Stroke (5~65mm) C : Stroke (5~130mm) D : Stroke (80~200mm)
- Rotary type :	F : Fork lever N : NAMUR shaft (direct mounting)
Gauge Block :	0 : Not mounted 1 : 6 bar (90 psi) 2 : 10 bar (150 psi)
By-pass :	N : None Y : Yes (auto/manual screw)

Description	Code
Position Feedback :	N : None O : Position transmitter (4~20mA output signal) L : 2 x alarm limit S : 2 x SPDT (only for rotary type) M : O + L Q : O + S (only for rotary type)
Communication :	N : None H : HART P : Profibus PA F : Fieldbus Foundation
Connection Threads : (pneumatic - electrical)	4 : NPT 1/4 - NPT 1/2
Mounting Bracket :	N : None L : IEC 60534-6-1 (for SS3SL) R : IEC 60534-6-2 (for SS3SR) VDI/DE 3845
Feedback Pin Guide Lever Set : (only for linear type SS3SL)	0 : Not included 1 : Included



< SS3L-IPC >



Specifications

Communication	Without	HART	Profibus-PA	Fieldbus
Input Signal	4 - 20 mA @ 24 VDC		9 - 32 VDC	
Min. / Max. Current	3.6 mA / 50 mA		-	
Current Consumption	-		15mA	16mA
Voltage Drop (Resistance)	8.9 VDC(445Ω)	9.4 VDC(470Ω)		
Air Supply Pressure	1.4 - 7.0 bar (20 - 100 psi)			
Air Capacity	80 ℓ/min = 4.8 N ^m /h = 2.8 scfm (Sup = 1.4 bar) 233 ℓ/min = 14 N ^m /h = 8.2 scfm (Sup = 6 bar)			
Air Consumption	2 ℓ/min = 0.12 N ^m /h = 0.07 scfm (Sup = 1.4 ~ 6 bar)			
Characteristic	Linearity < ±0.3% F.S Hysteresis < 0.2% F.S		Sensitivity < 0.2% F.S Repeatability < 0.2% F.S	
Performance Characteristic	Linear			
LCD Indication	4-digit LCD indicator			
Scan Time	2ms			
Valve Action	Direct action(DA) / Reverse action(RA)			
Operating Temperature	- 30 ~ +75 °C (- 22 ~ +167 °F) *			
Pneumatic Connections	PT 1/4, NPT 1/4			
Electrical Connections	PF 1/2, NPT 1/2			
Protection Class	Flameproof (IECEX / ATEX / KC Ex d IIC T6)			
Body Material	Aluminum die-cast / Stainless steel 316			
Weight	2.8 kg			

* -40 °C on request

How to Order

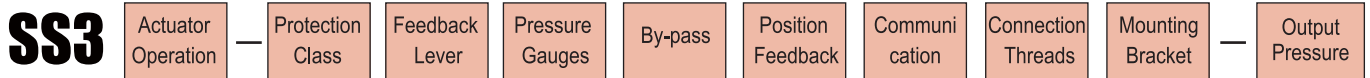

Description	Code
Actuator Operation :	L : Aluminum die-cast SL : Stainless steel 316
Protection Class :	F : Flameproof IECEX / ATEX / TR-CU Ex d IIC T6 K : Flameproof KC - Ex d IIC T6
Feedback Lever :	X : Not applicable
Gauge Block : (Supply pressure gauge)	1 : 6 bar (90 psi) 2 : 10 bar (150 psi)
By-pass :	N : None Y : Yes (auto/manual screw)

Description	Code
Position Feedback :	N : None O : Position transmitter (4~20mA output signal)
Communication :	N : None H : HART P : Profibus PA F : Fieldbus Foundation
Connection Threads : (pneumatic - electrical)	3 : PT 1/4 - PF 1/2 4 : NPT 1/4 - NPT 1/2
Mounting Bracket :	N : None
Output Pressure :	21 : 3...15 psi

Perfect combination with reliable fail freeze function and smart performance with innovative durable coil drive

**FAIL
FREEZE**



Features

- ▶ “Fail Freeze” function to help the valve stay at the last position on the electrical power supply or the pneumatic supply air by accident
- ▶ Easy and quick auto-calibration
- ▶ Detecting RA (reverse acting) or DA (direct acting) automatically regardless of wrong air connections
- ▶ Available to use for single or double acting without any special adjustments
- ▶ Compact design allowing to be installed on small actuators
- ▶ Providing error messages against performance failures
- ▶ Possible to test the actuator with any fixed signal under a test mode
- ▶ Programmable characteristic curve with 17 points
- ▶ Wide operating temperature range -30 ~ +80 °C
- ▶ Improved control of high-friction globe and ball valves by eliminating an overshoot and a hunting
- ▶ Low air consumption
- ▶ Providing a mounting bracket to meet IEC 60534-6-1 for linear valves
- ▶ Supporting a NAMUR mounting pattern VDI/VDE 3845 (IEC 60534-6-2) and providing a multi-size mounting bracket for rotary valves

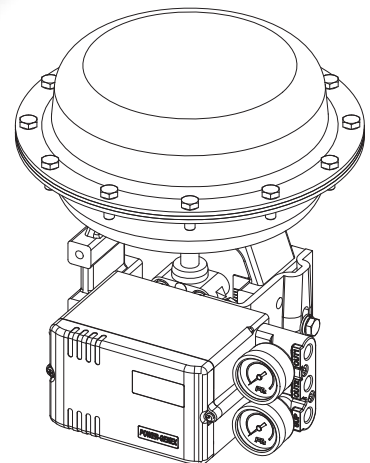

- SS5L (Linear Type)

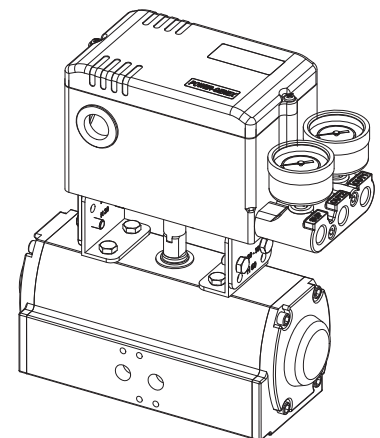

- SS5R (Rotary Type)

Options

- ▶ Output position transmitter (4 - 20 mA)
- ▶ 2 x alarm limit or micro switch (SPDT)
- ▶ Explosion proof type (IECEX / ATEX / KC Ex ia IIC T6/T5 - in progress)
- ▶ HART communication
- ▶ Profibus communication (in progress)
- ▶ Fieldbus Foundation communication (in progress)

Specifications

Input Signal	4 - 20 mA @ 24 VDC
Min. / Max. Current	3.6 mA / 50 mA
Voltage Drop (Resistance)	Without Hart : 8.9 VDC (445Ω @ 20 mA) With Hart : 9.4 VDC (470Ω @ 20 mA)
Stroke / Angle	Linear type : 5 - 130 mm * Rotary type : 25 - 120°
Air Supply Pressure	1.4 - 7 bar (20 - 100 psi), filtered, compressed dry and non-oiled to meet Class 3 of ISO 8573-1
Output Pressure Range	0 - 100% of supply air pressure
Air Capacity	80 ℓ/min = 4.8 N ^m /h = 2.8 scfm (Sup = 1.4 bar) 233 ℓ/min = 14 N ^m /h = 8.2 scfm (Sup = 6 bar)
Air Consumption	2 ℓ/min = 0.12 N ^m /h = 0.07 scfm (Sup = 1.4 ~ 6 bar)
Characteristic	Linearity < ±0.3% F.S Sensitivity < 0.2% F.S Hysteresis < 0.2% F.S Repeatability < 0.2% F.S
Performance Characteristic	Linear, EQ %, Quick open, User set (17 points)
LCD Indication	4-digit LCD indicator
Adjustable Speed	1 - 1000 (lowest 1, highest 1000)
Scan Time	2ms
Shut-off Value	Range 0 - 10% of position signal
Valve Action	Direct action (DA) / Reverse action (RA)
Operating Temperature	- 30 ~ +80 °C (- 22 ~ +176 °F) **
Pneumatic Connections	PT(Rc) 1/4 or NPT 1/4
Electrical Connections	2 x PF(G) 1/2, NPT 1/2, M20 x 1.5
Protection Class	IP66, intrinsically safe (IECEX / ATEX / KC Exia IIC T6/T5)
Body Material	Aluminum die-cast / powder-painted
Weight	1.6 kg

* Up to 200mm on request ** -40 °C on request

Principle of Operation

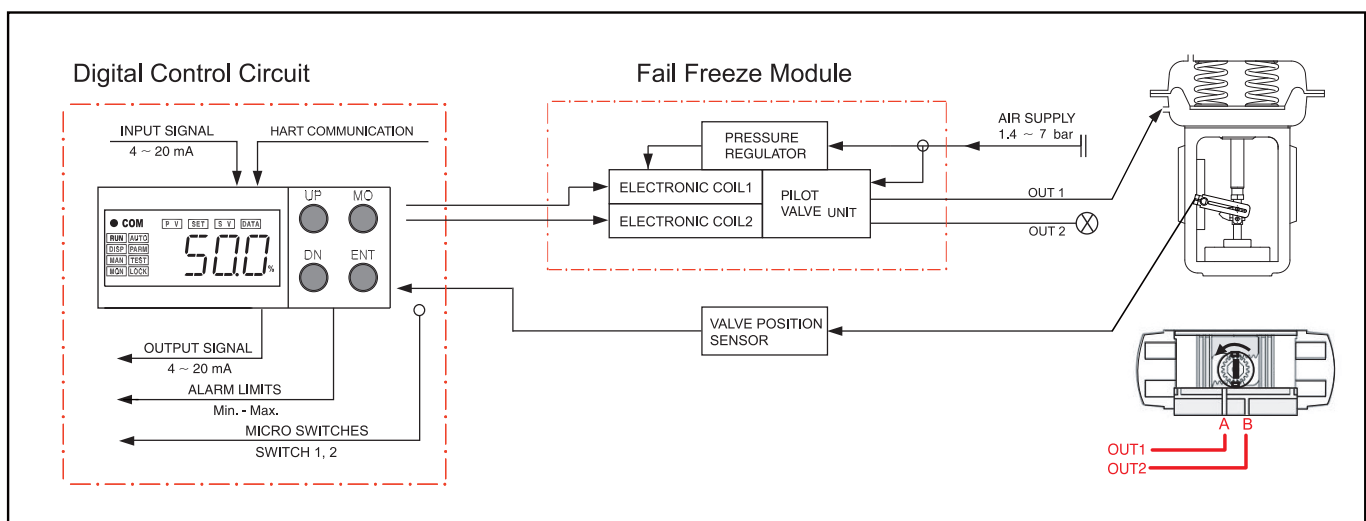

If 4-20mA input signal is supplied, the microprocessor compares the input signals and the feedback values and send the control signals to the I/P converter. A supply air is converted to the pneumatic signals by two electronic coils and moves the pilot valve until the control valve reaches the desired position. In case of a signal failure or a supply air failure, a venting air is blocked inside of the pilot valve and the valve stays at the last position because of an existing supply air pressure between the positioner and the actuator.

Smart Valve Positioner (fail freeze function)

SS5 Linear / Rotary

SS5 Front Cover Removed

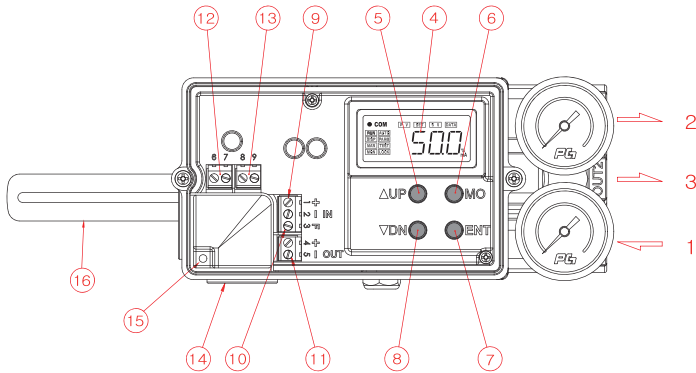

- 1 : Air supply
- 2 : OUT 1
- 3 : OUT 2
- 4 : Display LCD
- 5 : Up key
- 6 : Mode key
- 7 : Enter key
- 8 : Down key
- 9 : Input signal (+, -)
- 10 : Frame ground
- 11 : Output signal (+, -)
- 12 : Alarm limit 1
- 13 : Alarm limit 2
- 14 : Electrical connections
- 15 : Ground
- 16 : Feedback lever

Electrical Connections

- 1 (+) — IN. 4-20mA input signal
- 2 (-) — Frame Ground
- 3 (FG) — Frame Ground
- 4 (+) — OUT. 4-20mA output signal
- 5 (-) — OUT. 4-20mA output signal
- 6 (+) — LS1. (Low) Alarm limit 1
- 7 (-) — LS1. (Low) Alarm limit 1
- 8 (+) — LS2. (High) Alarm limit 2
- 9 (-) — LS2. (High) Alarm limit 2

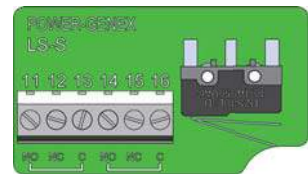
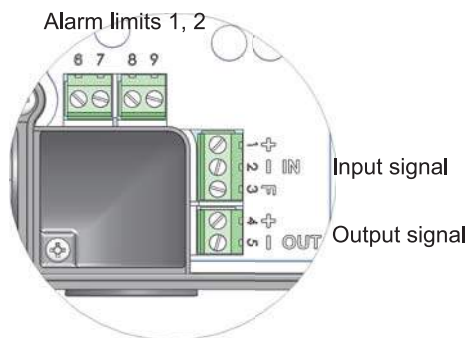

Micro switches 1, 2

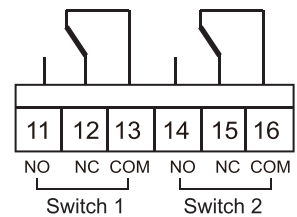

How to Order

SS5

- Actuator Operation
- Protection Class
- Feedback Lever
- Pressure Gauges
- Position Feedback
- Communication
- Connection Threads
- Mounting Bracket
- Feedback Pin Guide Lever Set

Description	Code
Actuator Operation :	L : Linear type R : Rotary type
Protection Class :	I : Intrinsically safe (IECEX Ex ia IIC T6/T5, ATEX Ex ia IIC T6/T5) K : Intrinsically safe (KC Ex ia IIC T6/T5) W: Weatherproof to IP66
Feedback Lever : - Linear Type	A : Stroke (5 ~ 30mm) B : Stroke (5 ~ 65mm) C : Stroke (5 ~ 130mm) D : Stroke (80 ~ 200mm)
- Rotary Type	F : Fork lever N : Namur shaft (direct mounting)
Pressure Gauge Block :	0 : Not mounted 1 : 6 bar (90 psi) 2 : 10 bar (150 psi)

Description	Code
Position Feedback :	N : None O : Position transmitter (4 ~ 20mA output signal) L : 2 x alarm limit S : 2 x micro switch (SPDT) M : O+L Q : O+S
Communication :	N : None H : HART
Connection Threads : (pneumatic - electrical)	3 : PT(Rc) 1/4 – PF(G)1/2 4 : NPT 1/4 – NPT 1/2 5 : PT(Rc) 1/4 – M20 x 1.5
Mounting Bracket :	N : None L : IEC 60534-6-1 (for SS5L) R : VDI/VDE 3845 / IEC 60534-6-2 (for SS5R)
Feedback Pin Guide Lever Set : (only for linear type SS5L)	0 : Not included 1 : Included

Dimensions

- SS5L (Linear Type)

Electrical connections
2 - PF(NPT)1/2

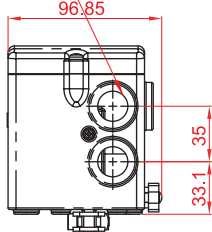

Electrical connections
PF(NPT)1/2

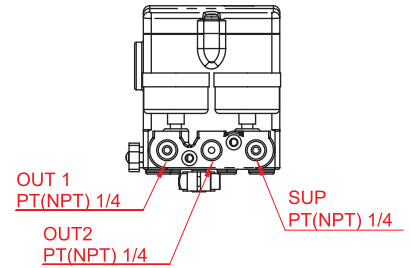
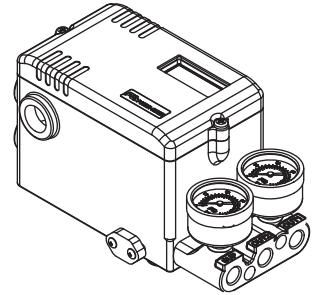
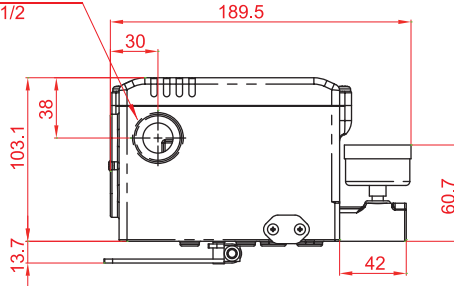

A,B,C,D TYPE LEVER

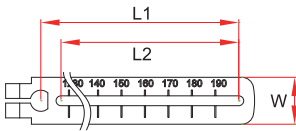

LEVER TYPE	L1(mm)	L2(mm)	W(mm)
A	30	21.40	20
B	65	55.90	20
C	130	121.40	20
D	200	191.40	20

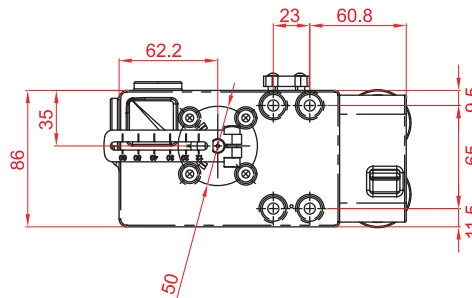

- SS5R (Rotary Type)

Electrical connections
2 - PF(NPT)1/2

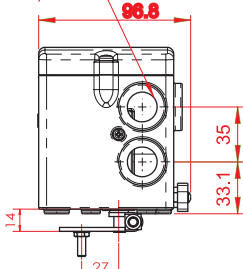

< Fork Lever Type >

Electrical connections
PF(NPT)1/2

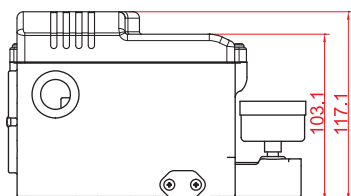
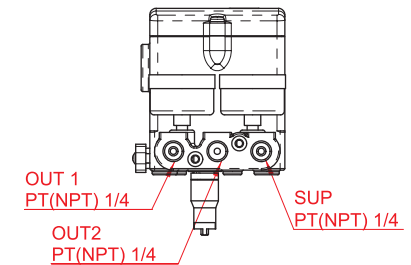
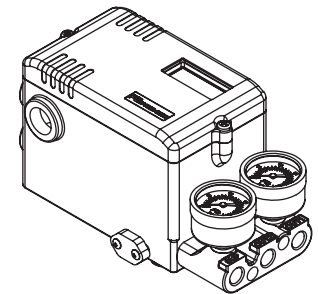
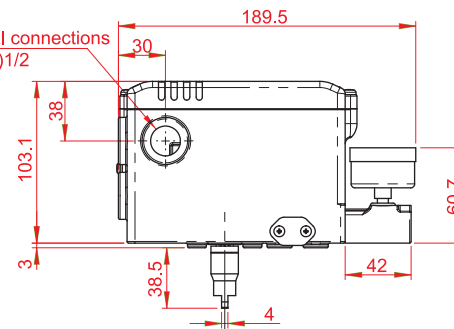

< SS5 with 2 x SPDT Micro S/W >

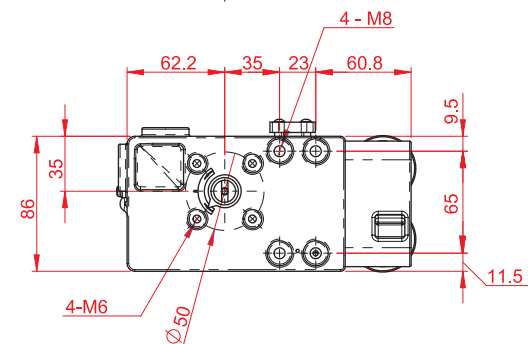



Smartest valve control device meeting a dynamic performance and a precise setting with a piezoelectric technology and an optimized auto-calibration program

Features

- ▶ Auto-Calibration for optimum conditions
- ▶ Precise control performance and high dynamic response
- ▶ Easy operation with four-key pads and full text graphical LCD
- ▶ Single and double acting
- ▶ Low air consumption due to piezo electric microvalve
- ▶ Pressure regulator built-in to eliminate variations in supply air pressure
- ▶ Problem-free characteristics on a small actuator
- ▶ High resistance against shock and vibration
- ▶ Mounting on linear actuators according to IEC 534

Options

- ▶ Position transmitter (4...20mA output signal)
- ▶ 2 x alarm limit (Min., Max.)
- ▶ Explosion proof type (KC Ex d IIB+H₂ T6 IP66)
- ▶ HART communication (FSK)

Specifications

Input Signal	4 - 20 mA @ 24 VDC
Voltage Drop	8.5 VDC @ 20 mA (425 Ω)
Min. / Max. Current	3.6 mA / 50 mA
Required Load Voltage (≅ Ω @ 20mA)	Without HART : 8.5V (≅425 Ω) With HART : 9.2V (≅460 Ω)
Air Supply Pressure	1.4 - 7.0 bar (20 - 100 psi) Filtered compressed dry and non-oiled air
Output Pressure	0 - 100% supply air pressure / single or double action
Shut-off Value	Range 0 - 5% of position signal
Air Capacity	80 l/min = 4.8 N ^m /h = 2.8 scfm (Sup = 1.4 bar)
Air Consumption	1.3 l/min = 0.08 N ^m /h = 0.05 scfm (Sup = 1.4 ~ 6 bar)
Humidity Limits	< 90% RH, non-condensing
Stroke / Angle	5 ~ 80mm (max. up to 150mm) 0 ~ 90° (max. up to 100°)
Adjustable Speed	1 - 1000 (lowest 1, highest 1000)
LCD Indication	4-digit LCD indicator
Scan Time	2 ms
Valve Action	Position 0 - 100% / direct action (DA) / reverse action (RA)
Characteristic Curve	Linear, E.Q.% (1:25 or 1:50), Quick open Linearity <= 0.3% / sensitivity <= 0.2% / hysteresis <= 0.2%
Operating Temperature	- 30 ~ +70 °C
Protection Class	IP66, flameproof (KC Ex d IIB+H ₂ T6 IP66)
Body Material	Aluminum die-cast
Pneumatic Connections	PT(Rc) 1/4 or NPT 1/4
Electrical Connections	2 x PF(G) 1/2 or NPT 1/2
Weight	2.5 kg

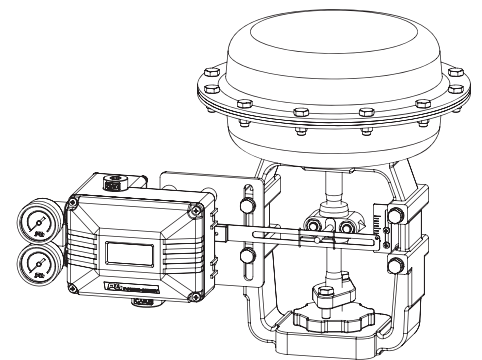

- SSL (Linear Type)

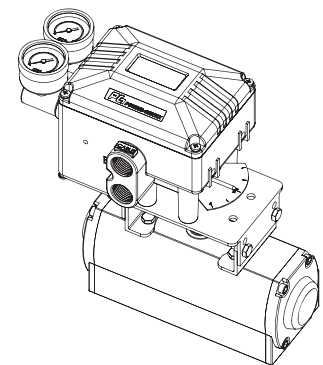

- SSR (Rotary Type)

Note : Equal percentage or Quick-open option is available. Please contact for more details

Board View

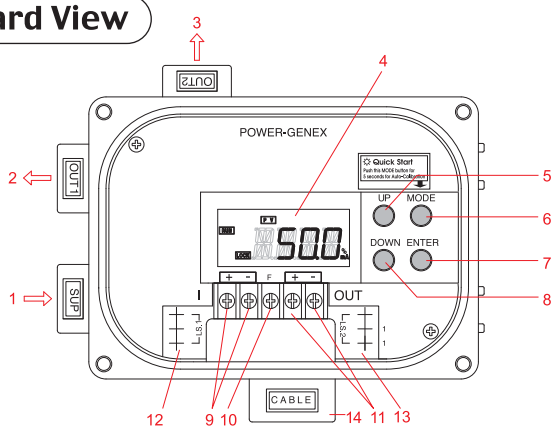

- 1 : Air supply
- 2 : Output 1
- 3 : Output 2
- 4 : Display LCD
- 5 : Up key
- 6 : Mode key
- 7 : Enter key
- 8 : Down key
- 9 : Input signal (+, -)
- 10 : Frame ground
- 11 : Output signal (+ -)
- 12 : Alarm limit 1
- 13 : Alarm limit 2
- 14 : Electrical connections

Air Connections

- SSL (Linear Type)

Direct Acting (DA)		Reverse Acting (RA)	
As the input signal increases, Valve stem moves downwards Actuator : DA Switch position : DA		As the input signal increases, Valve stem moves upwards Actuator : RA Switch position : RA	
As the input signal increases, Valve stem moves downwards Actuator : DA Switch position : DA		As the input signal increases, Valve stem moves upwards Actuator : RA Switch position : RA	
As the input signal increases, Valve stem moves downwards Switch position : DA		As the input signal increases, Valve stem moves upwards Switch position : RA	

- SSR (Rotary Type)

Spring Return	Double Acting	Double Acting
As the input signal increases, Actuator shaft rotates counter-clockwise	As the input signal increases, Actuator shaft rotates counter-clockwise	As the input signal increases, Actuator shaft rotates clockwise
Spring Return		Double Acting
Reverse Acting	Out 1 : piped, Out2 : plugged	Out 1 : piped to Actuator port A, Out2 : piped to Actuator port B
Direct Acting	Out 1 : plugged, Out2 : piped	Out 1 : piped to Actuator port B, Out2 : piped to Actuator port A

Measuring 4–20mA Output Signal

1) Specifications

Output Signal	4 - 20 mA, 2 - wire
Power Supply Rating	15 - 30V DC
Recommended Power Supply	24V DC
Operating Temperature	-20 - +70°C
Input Impedance	0 - 430Ω
Characteristic	Linear
Linearity	1.0 % F.S.
Hysteresis	0.5 % F.S.
Repeatability	± 0.5 % F.S.
Adjustment	Zero and span
Rotary Angle	50...90° (max. 100°)

2) With mA Loop Calibrator

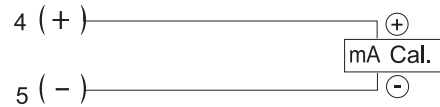

3) With Multi-Meter

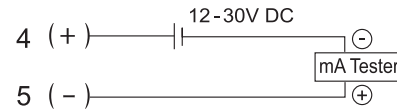

Electrical Connections

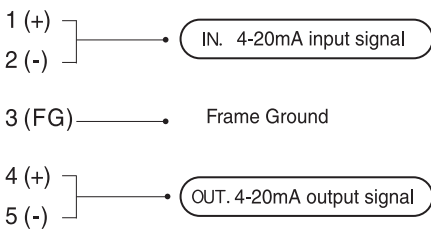

Setting Alarm Limits

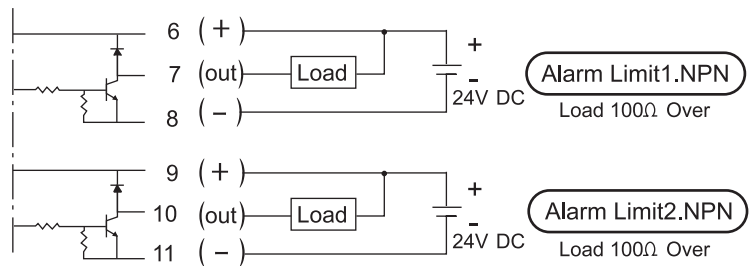

How to Order

SS

Actuator Operation

Protection Class

Feedback Lever

Pressure Gauge (SUP. OUT)

Position Feedback

HART Communication

Connection Threads

Mounting Bracket

Description	Code
Actuator Operation :	L : Linear type R : Rotary type
Protection Class :	F : Flameproof (KC Ex d IIB+H ₂ T6 IP66) W : Weatherproof to IP66
Feedback Lever :	A : Stroke (5~40mm) B : Stroke (5~80mm) C : Stroke (up to 150mm) F : Fork lever N : NAMUR shaft(direct mounting)
Pressure Gauge :	1 : 6 bar (90 psi) 2 : 10 bar (150 psi)

Description	Code
Position Feedback :	N : None O : Position transmitter (4~20mA output signal) L : 2 x alarm limit M : O + L
HART Communication :	N : None H : HART Communication
Connection Threads : (pneumatic - electrical)	3 : PT(Rc) 1/4 - PF(G) 1/2 4 : NPT 1/4 - NPT 1/2 5 : PT(Rc) 1/4 - M20 x 1.5
Mounting Bracket :	N : None L : DIN / IEC 534 R : Multi-size bracket for DIN VDI/VDE 3845 (130x30x50 bracket on request)

Dimensions

- SSL (Linear Type)

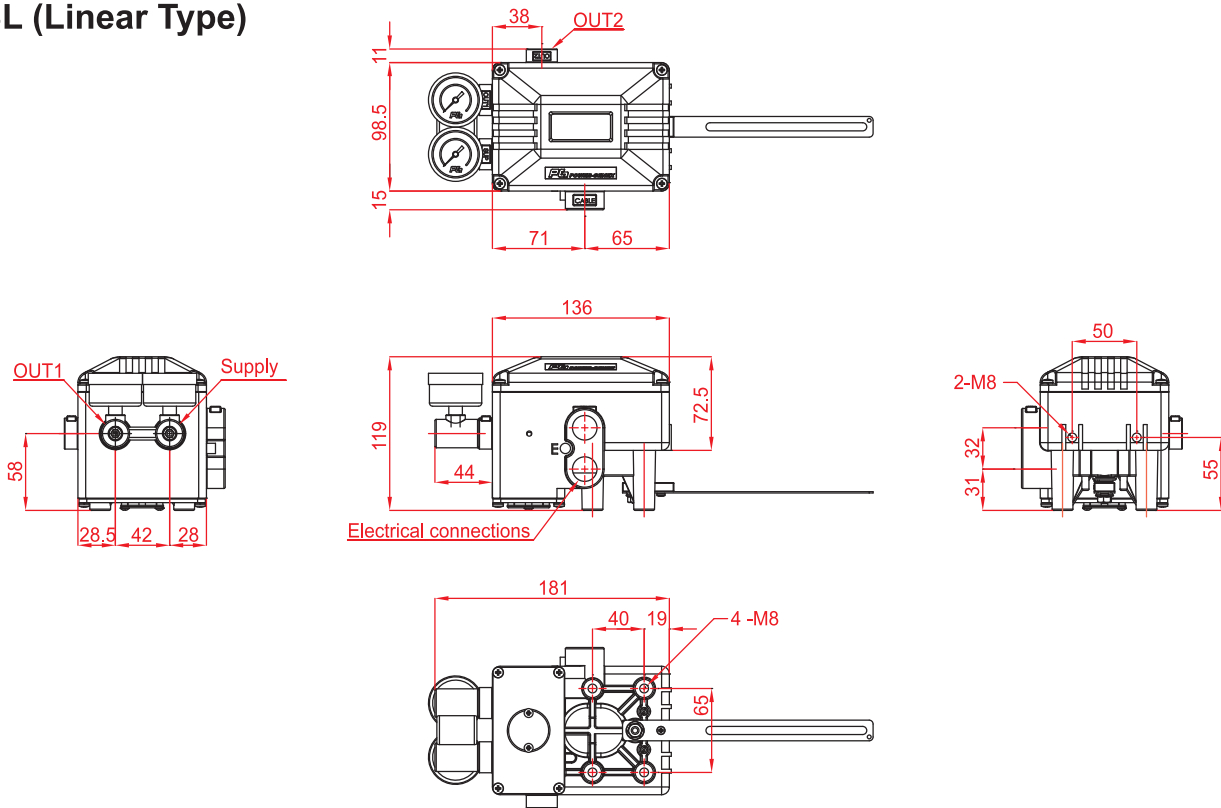

- SSR (Rotary Type)

