



**Dynamic valve drive to convert 4-20mA current signal to pneumatic output pressure with state-of-the art piezoelectric technology**

### Features

- ▶ Rugged aluminum die-cast housing
- ▶ Precise control performance and high dynamic response
- ▶ Simple and easy to set
- ▶ Low air consumption due to piezo electric microvalve

### Specifications

Model	IPC
Input Signal	4 - 20 mA @ 24 VDC, 2-wire
Output Pressure	Max. 3 bar (45 psi)
Air Supply Pressure	1.4 - 4 bar (20 - 60 psi)
Air Consumption	1.3 l/min = 0.08 N <sup>m</sup> /h = 0.05 scfm
Output Characteristic	Linear to input signal
Action	Direct
Total Error	Max. error ±0.3% of span (linearity + hysteresis + repeatability)
Supply Air	Filtered compressed, dry and non-oiled air (up to 5 micron)
Operating Temperature	-20°C - +70°C
Protection Class	IP55
Impedance	425 Ω @ 20 mA
Mounting Type	Rail (to DIN EN 50022)
Pneumatic Connection	PT(Rc) 1/8
Electrical Connections	PG 9
Body Material	Aluminum die-cast
Weight	820 g

### How to Order

Output Pressure	Required Supply Air	Part Number
0 - 1 bar (0 - 15 psi)	1.5 bar (23 psi)	IPC - 01
0.2 - 1 bar (3 - 15 psi)	1.5 bar (23 psi)	IPC - 21
0.4 - 2 bar (6 - 30 psi)	2.5 bar (38 psi)	IPC - 42
0.2 - 3 bar (3 - 45 psi)	3.5 bar (53 psi)	IPC - 23
Other Pressure		On request

## Applications

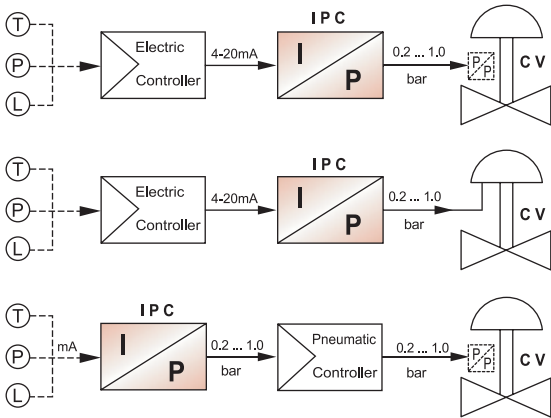

Ⓣ Temp. Transmitter Ⓟ Press. Transmitter Ⓛ Level Transmitter

IPC : I/P Converter, CV : Pneumatic Control Valve

## Board view

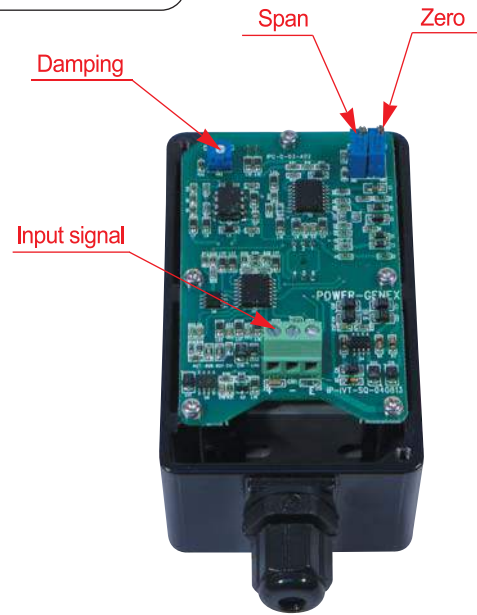

## Dimensions

