

# ELECTRIC MOTOR-HOLLOW SHAFT TYPE

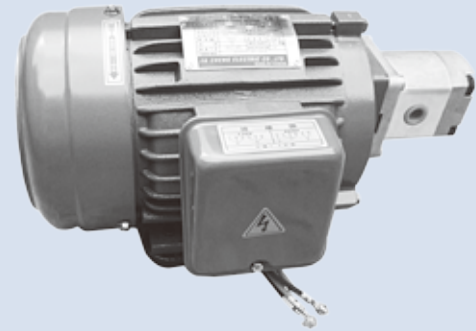

## How to order

**H H S 01 - \* - 2HP - \* - \* - \* - \***  
 1 2 3 4 5 6 7 8 9 10

1	Model	Motor for hydraulic pumps
2	Mounting type	H: Horizontal type V: Vertical type
3	Material of frame	S: Cast iron (normal) F: Steel A: Aluminum
4	Mounting Flang	01: Hollow shaft type (normal) 02: Motor-pump with adaptor type 03: In oil type
5	Wiring box position (viewed from fan cover)	R: Right side (normal) L: Left side U: Upside
6	Horse power	
7	No. of phase	1: Single phase 3: 3 phase
8	No. of pole	2: 2 pole 4: 4 pole (normal) 6: 6 pole
9	Voltage / Hertz	
10	Model number of pump	

## Dimensions

### HHS01 for pump VP-F8~20

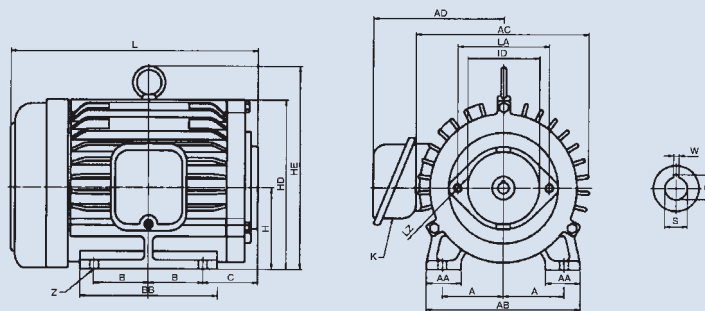

**Tolerance**  
 ID: +0.01~0.03  
 S: H7  
 T: +0.05~0.1  
 W: +0.03~0.05

Power Output (HP)	Frame No.	No. of Phase	A	AA	AB	AC	AD	B	BB	C	H	HD	HE	K	L	Z	Pump Mounting Dimensions						Weight (kg)	
																	LA	LZ	ID	S	T	W		
1/2	1/4	80S	3	62.5	37	156	174	138	50	122	61	80	175	-	22	244	10	106	M10x1.5	82.55	12.7	14.3	3.175	12.5
1	1/2	80M	3	62.5	37	156	174	138	50	133	67	80	175	-	22	253	10	106	M10x1.5	82.55	12.7	14.3	3.175	16
2	1	90L	3	70	42	179	198	149	62.5	158	57	90	197	-	22	282	10	106	M10x1.5	82.55	12.7	14.3	3.175	23
3	2	100L	3	80	45	196	225	162	70	175	65	100	210	245	22	300	12	106	M10x1.5	82.55	12.7	14.3	3.175	32
5	3	112M	3	95	47	228	234	167	70	178	84	112	232	266	22	333	12	106	M10x1.5	82.55	12.7	14.3	3.175	40
1/2	-	80M	1	62.5	37	156	174	143	50	133	67	80	175	-	28	272	10	106	M10x1.5	82.55	12.7	14.3	3.175	16
1	-	90L	1	70	42	179	198	155	62.5	158	65	90	197	-	28	297	10	106	M10x1.5	82.55	12.7	14.3	3.175	25
2	-	90L	1	70	42	179	198	155	62.5	158	65	90	197	-	28	297	10	106	M10x1.5	82.55	12.7	14.3	3.175	28
3	-	112M	1	95	47	228	234	177	70	178	84	112	235	266	28	343	12	106	M10x1.5	82.55	12.7	14.3	3.175	45

# ELECTRIC MOTOR-HOLLOW SHAFT TYPE

## Dimensions

**HHS01 for pump**  
**VP-F23~40**  
**VP5-F20~40,**  
**50T(ø19.05)**

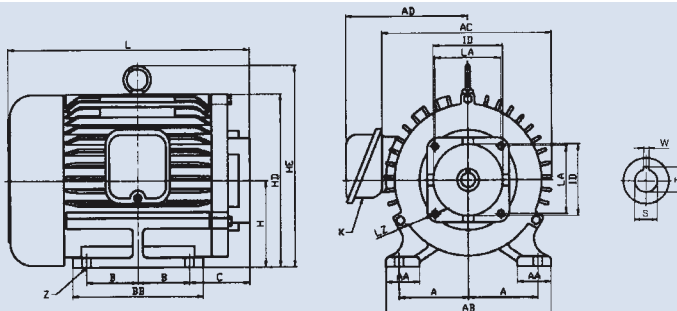

**Tolerance**  
 ID: +0.01~0.03  
 S: H7  
 T: +0.05~0.1  
 W: +0.03~0.05

Power Output (HP)	Frame No.	No. of Phase	A	AA	AB	AC	AD	B	BB	C	H	HD	HE	K	L	Z	Pump Mounting Dimensions					Weight (kg)		
																	LA	LZ	ID	S	T		W	
4P	6P																							
1	1/2	80M	3	62.5	37	156	174	138	50	133	73	80	175	-	22	260	10	90	M10x1.5	95.02	19.05	21.7	4.8	16
2	1	90L	3	70	42	179	198	149	62.5	158	57	90	197	-	22	270	10	90	M10x1.5	95.02	19.05	21.7	4.8	23
3	2	100L	3	80	45	196	225	162	70	175	65	100	210	245	22	300	12	90	M10x1.5	95.02	19.05	21.7	4.8	32
5	3	112M	3	95	47	228	234	167	70	178	82	112	232	266	22	331	12	90	M10x1.5	95.02	19.05	21.7	4.8	40
7 1/2	5	132S	3	108	47	255	266	185	70	176	81	132	270	304	28	352	12	90	M10x1.5	95.02	19.05	21.7	4.8	52
10	7 1/2	132M	3	108	57	255	266	185	89	214	75	132	270	312	28	386	12	90	M10x1.5	95.02	19.05	21.7	4.8	75
1	-	90L	1	70	42	179	198	155	62.5	158	65	90	197	-	28	300	10	90	M10x1.5	95.02	19.05	21.7	4.8	25
2	-	90L	1	70	42	179	198	155	62.5	158	65	90	197	-	28	300	10	90	M10x1.5	95.02	19.05	21.7	4.8	28
3	-	112M	1	95	47	228	234	177	70	178	82	112	235	266	28	341	12	90	M10x1.5	95.02	19.05	21.7	4.8	45
5	-	112M	1	95	47	228	234	177	70	178	97	112	235	266	28	371	12	90	M10x1.5	95.02	19.05	21.7	4.8	50

## Dimensions

**HHS01 for pump**  
**DVP-F12+12~F20+20,**  
**HGP-3A**

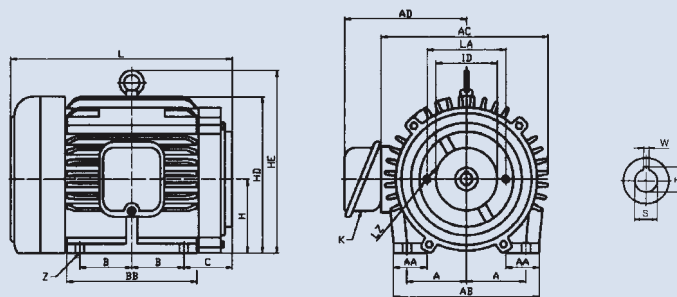

**Tolerance**  
 ID: +0.01~0.03  
 S: H7  
 T: +0.05~0.1  
 W: +0.03~0.05

Power Output (HP)	Frame No.	No. of Phase	A	AA	AB	AC	AD	B	BB	C	H	HD	HE	K	L	Z	Pump Mounting Dimensions					Weight (kg)		
																	LA	LZ	ID	S	T		W	
1/2	1/4	80S	3	62.5	37	156	174	138	50	122	61	80	175	-	22	244	10	106	M10x1.5	82.55	15.88	17.6	4	12.5
1	1/2	80M	3	62.5	37	156	174	138	50	133	67	80	175	-	22	253	10	106	M10x1.5	82.55	15.88	17.6	4	16
2	1	90L	3	70	42	179	198	149	62.5	158	57	90	197	-	22	282	10	106	M10x1.5	82.55	15.88	17.6	4	23
3	2	100L	3	80	45	196	225	162	70	175	65	100	210	245	22	300	12	106	M10x1.5	82.55	15.88	17.6	4	32
5	3	112M	3	95	47	228	234	167	70	178	84	112	232	266	22	333	12	106	M10x1.5	82.55	15.88	17.6	4	40
7 1/2	5	132S	3	108	47	255	266	185	70	176	81	132	270	304	28	352	12	106	M10x1.5	82.55	15.88	17.6	4	52
10	7 1/2	132M	3	108	57	255	266	185	89	214	75	132	270	312	28	386	12	106	M10x1.5	82.55	15.88	17.6	4	75
1/2	-	80M	1	62.5	37	156	174	143	50	133	67	80	175	-	28	272	10	106	M10x1.5	82.55	15.88	17.6	4	16
1	-	90L	1	70	42	179	198	155	62.5	158	65	90	197	-	28	297	10	106	M10x1.5	82.55	15.88	17.6	4	25
2	-	90L	1	70	42	179	198	155	62.5	158	65	90	197	-	28	297	10	106	M10x1.5	82.55	15.88	17.6	4	28
3	-	112M	1	95	47	228	234	177	70	178	84	112	235	266	28	343	12	106	M10x1.5	82.55	15.88	17.6	4	45
5	-	112M	1	95	47	228	234	177	70	178	99	112	235	266	28	373	12	106	M10x1.5	82.55	15.88	17.6	4	50



# ELECTRIC MOTOR-HOLLOW SHAFT TYPE

## Dimensions

### HHS01 for pump NOP, TOP

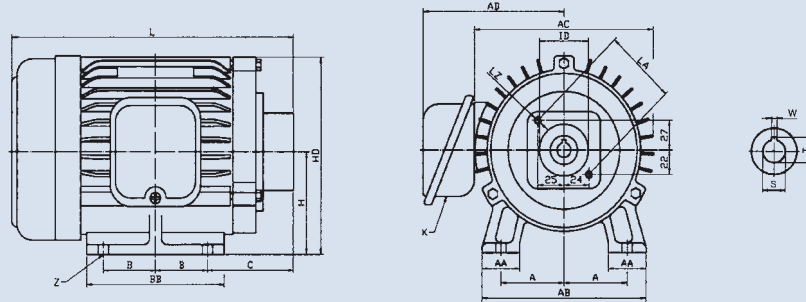

**Tolerance**  
 ID: +0.01~0.03  
 S: H7  
 T: +0.05~0.1  
 W: +0.03~0.05

Power Output (HP)		Frame No.	No. of Phase	A	AA	AB	AC	AD	B	BB	C	H	HD	HE	K	L	Z	Pump Mounting Dimensions						Weight (kg)
4P	6P																	LA	LZ	ID	S	T	W	
1/2	1/4	80S	3	62.5	37	156	174	138	50	122	74	80	175	-	22	257	10	68	M8x1.25	47	14	16	4	12.5
1	1/2	80M	3	62.5	37	156	174	138	50	133	80	80	175	-	22	266	10	68	M8x1.25	47	14	16	4	16
2	1	90L	3	70	42	179	198	149	62.5	158	75	90	197	-	22	288	10	68	M8x1.25	47	14	16	4	23
1/2	-	80M	1	62.5	37	156	174	138	50	133	80	80	175	-	22	285	10	68	M8x1.25	47	14	16	4	16
1	-	90L	1	70	42	179	198	155	62.5	158	83	90	197	-	28	310	10	68	M8x1.25	47	14	16	4	25
2	-	90L	1	70	42	179	198	155	62.5	158	83	90	197	-	28	310	10	68	M8x1.25	47	14	16	4	28

## Dimensions

### HHS01 for pump 50T

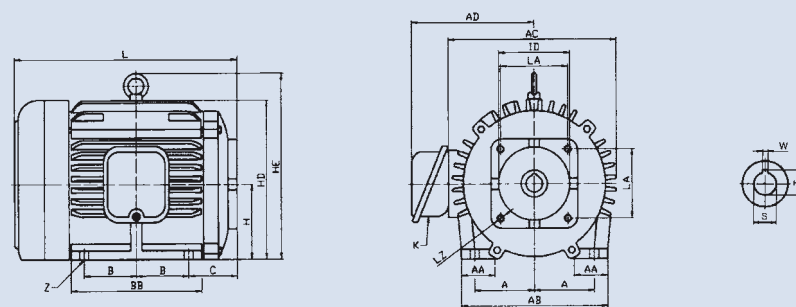

**Tolerance**  
 ID: +0.01~0.03  
 S: H7  
 T: +0.05~0.1  
 W: +0.03~0.05

Power Output (HP)		Frame No.	No. of Phase	A	AA	AB	AC	AD	B	BB	C	H	HD	HE	K	L	Z	Pump Mounting Dimensions						Weight (kg)
4P	6P																	LA	LZ	ID	S	T	W	
2	1	90L	3	70	42	179	198	149	62.5	158	56	90	197	-	22	270	10	90	M10x1.5	96	22	24	5	23
3	2	100S	3	80	45	196	225	162	70	175	65	100	210	245	22	300	12	90	M10x1.5	96	22	24	5	32
5	3	112M	3	95	47	228	234	167	70	178	85	112	232	266	22	344	12	90	M10x1.5	96	22	24	5	40
7 1/2	5	132S	3	108	47	255	266	185	70	176	81	132	270	304	28	352	12	90	M10x1.5	96	22	24	5	52
10	7 1/2	132M	3	108	57	255	266	185	89	214	75	132	270	312	28	386	12	90	M10x1.5	96	22	24	5	75
2	-	90L	1	70	42	179	198	155	62.5	158	56	90	197	-	28	300	10	90	M10x1.5	96	22	24	5	28
3	-	112M	1	95	47	228	234	177	70	178	85	112	235	266	28	344	12	90	M10x1.5	96	22	24	5	45
5	-	112M	1	95	47	228	234	177	70	178	100	112	235	266	28	374	12	90	M10x1.5	96	22	24	5	50

# ELECTRIC MOTOR-HOLLOW SHAFT TYPE

## Dimensions

### HHS01 for pump HGP-1A (4BE)

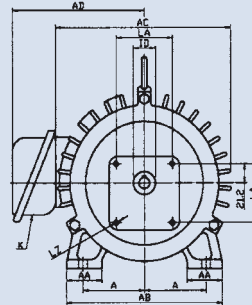
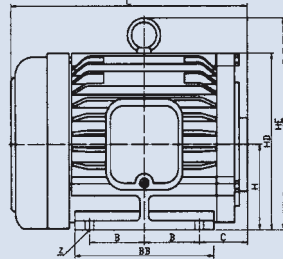

**Tolerance**  
 ID: +0.01~0.03  
 S: H7  
 T: +0.05~0.1  
 W: +0.03~0.05

Power Output (HP)		Frame No.	No. of Phase	A	AA	AB	AC	AD	B	BB	C	H	HD	HE	K	L	Z	Pump Mounting Dimensions					Weight (kg)	
4P	6P																	LA	LZ	ID	S	T		W
1/2	1/4	80S	3	62.5	37	156	174	138	50	122	56	80	175	-	22	239	10	64	M6x1.0	30	12	13.7	4	12.5
1	1/2	80M	3	62.5	37	156	174	138	50	133	62	80	175	-	22	248	10	64	M6x1.0	30	12	13.7	4	16
2	1	90L	3	70	42	179	198	149	62.5	158	55	90	197	-	22	268	10	64	M6x1.0	30	12	13.7	4	23
3	2	112S	3	95	47	228	234	167	70	171	57	112	235	270	22	287	12	64	M6x1.0	30	12	13.7	4	32
1/2	-	80M	1	62.5	37	156	174	143	50	133	62	80	175	-	28	270	10	64	M6x1.0	30	12	13.7	4	16
1	-	90L	1	70	42	179	198	155	62.5	158	63	90	197	-	28	297	10	64	M6x1.0	30	12	13.7	4	25
2	-	90L	1	70	42	179	198	155	62.5	158	63	90	197	-	28	297	10	64	M6x1.0	30	12	13.7	4	28
3	-	112M	1	95	47	228	234	177	70	178	82	112	235	266	28	347	12	64	M6x1.0	30	12	13.7	4	45

## Dimensions

### HHS01 for pump HGP-2A, PA

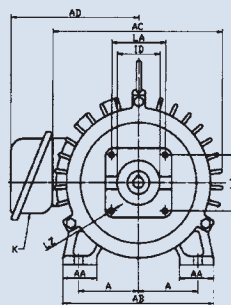
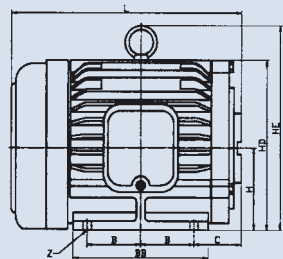

**Tolerance**  
 ID: +0.01~0.03  
 S: H7  
 T: +0.05~0.1  
 W: +0.03~0.05

Power Output (HP)		Frame No.	No. of Phase	A	AA	AB	AC	AD	B	BB	C	H	HD	HE	K	L	Z	Pump Mounting Dimensions					Weight (kg)	
4P	6P																	LA	LZ	ID	S	T		W
1/2	1/4	80S	3	62.5	37	156	174	138	50	122	58	80	175	-	22	241	10	63.5	M8x1.25	50.77	12.5	14	4	12.5
1	1/2	80M	3	62.5	37	156	174	138	50	133	64	80	175	-	22	250	10	63.5	M8x1.25	50.77	12.5	14	4	16
2	1	90L	3	70	42	179	198	149	62.5	158	57	90	197	-	22	270	10	63.5	M8x1.25	50.77	12.5	14	4	23
3	2	100L	3	80	45	196	225	162	70	175	65	100	210	245	22	300	12	63.5	M8x1.25	50.77	12.5	14	4	32
5	3	112M	3	95	47	228	234	167	70	178	84	112	235	266	22	333	12	63.5	M8x1.25	50.77	12.5	14	4	40
1/2	-	80M	1	62.5	37	156	174	143	50	133	64	80	175	-	28	272	10	63.5	M8x1.25	50.77	12.5	14	4	16
1	-	90L	1	70	42	179	198	155	62.5	158	65	90	197	-	28	295	10	63.5	M8x1.25	50.77	12.5	14	4	25
2	-	90L	1	70	42	179	198	155	62.5	158	65	90	197	-	28	295	10	63.5	M8x1.25	50.77	12.5	14	4	28
3	-	112M	1	95	47	228	234	177	70	178	84	112	235	266	28	343	12	63.5	M8x1.25	50.77	12.5	14	4	45
5	-	112M	1	95	47	228	234	177	70	178	99	112	235	266	28	373	12	63.5	M8x1.25	50.77	12.5	14	4	50