

# CHECK VALVE

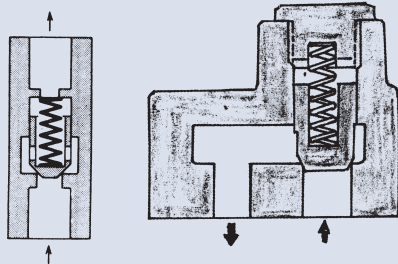

## How to order

### CRG - 06 - 5

- | 1 | 2   | 3 |
|---|---|---|
| 1 | Model CRG: Sub-plate mounting CIT: Thread connection                      |   |
| 2 | Valve size 03: 3/8" 04: 1/2" 06: 3/4" 08: 1" 10: 1-1/4" 12: 1-1/2" 16: 2" |   |
| 3 | Cracking pressure (bar) 5: 0.5 50: 5                                      |   |

## Specifications

Model		Rated Flow (lpm)	Max. Operating Pressure (bar)	Cracking Pressure (bar)	Weight (kg)	
Sub-Plate Mounting	Thread Connection					
CRG-03	CIT-03	40	230	05: 0.5 50: 5	2	0.18
-	CIT-04	60			-	0.32
CRG-06	CIT-06	125			4	0.49
-	CIT-08	180			-	1.1
CRG-10	CIT-10	300			8	1.8
-	CIT-12	420			-	2.7
-	CIT-16	600	-	3.62		

## Dimensions

### CIT-03,04,06,08,10,12,16

### CRG-03,04,06

Unit: mm

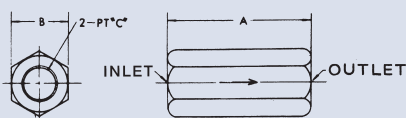

Model	A	B	C
CIT-03	70	23	3/8
CIT-04	74	29	1/2
CIT-06	95	35	3/4
CIT-08	112	46	1
CIT-10	132	55	1-1/4
CIT-12	140	65	1-1/2
CIT-16	156	80	2

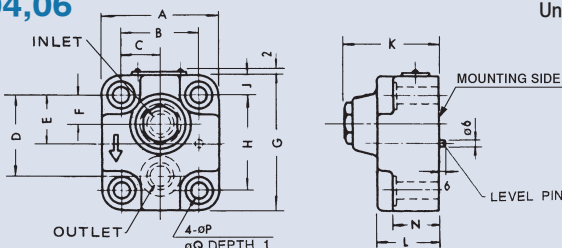

Model	A	B	C	D	E	F	G	H	J	K	L	N	P	Q	Bolt size
CRG-03	68	47.6	23.8	47.6	30.1	12.7	80	60.3	10	72	55	46	11	17.5	M10 x 60L x 4pcs
CRG-06	98	65.1	32.6	68.2	40.5	22.2	114	80.9	16.5	81	53	38	17.5	26	M16 x 60L x 4pcs
CRG-10	130	92.1	46.1	71.4	46	20.6	130	92.1	19	96	65	47	21.5	32	M20 x 75L x 4pcs

### CRGM-03

### CRGM-06

### CRGM-10

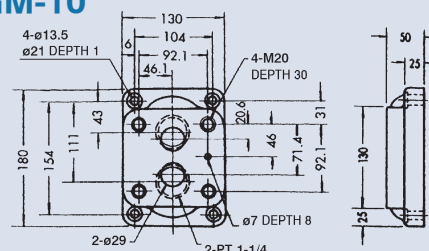
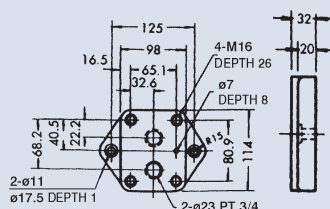
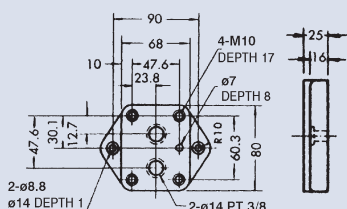

# CHECK VALVE



## How to order

### CRG - 06 - 5 - 50

	1	2	3	4
1	Model	Sub-plate mounting		
2	Valve size	03: 3/8" (ISO 5781-AG-06-2-A)	06: 3/4" (ISO 5781-AH-08-2-A)	10: 1-1/4" (ISO 5781-AJ-10-2-A)
3	Cracking pressure (bar)	5: 0.5	50: 5	
4	ISO standard			

## Specifications

Model	Rated Flow (lpm)	Max. Operating Pressure (bar)	Cracking Pressure (bar)	Weight (kg)
CRG-03	40	250	5: 0.5 50: 5	2.2
CRG-06	125			3.2
CRG-10	300			6.5

## Dimensions

### CRG-03-✱-50, CRG-06-✱-50

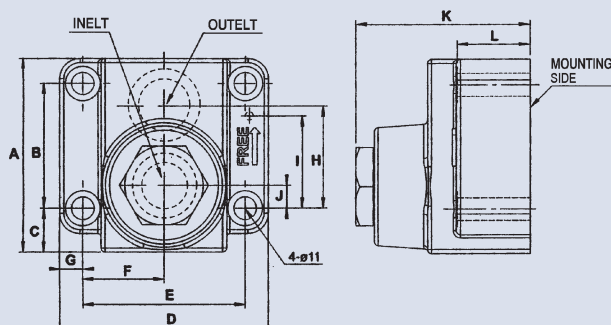

Model	A	B	C	D	E	F
CRG-03-✱-50	73	42.9	18	89	66.7	33.4
CRG-06-✱-50	94	60.3	21.5	102	79.4	39.7

Model	G	H	I	J	K	L
CRG-03-✱-50	11.2	35.7	31.8	7	68	33
CRG-06-✱-50	11.3	49.2	44.5	11.1	85	35

### CRG-10-✱-50

Unit: mm

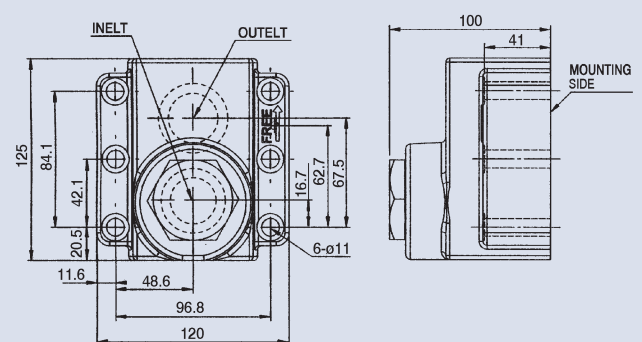

# PILOT OPERATED CHECK VALVE

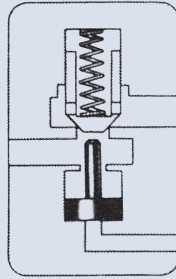
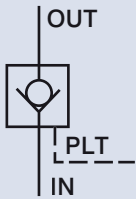

## How to order

### CPD - T - 06 - E - 50

- | 1 | 2   | 3 | 4 | 5 |
|---|---|---|---|---|
| 1 | Model   |   |   |   |
| 2 | Mounting type G: Sub-plate mounting T: Thread connection F: Flange connection |   |   |   |
| 3 | Valve size 03: 3/8" 06: 3/4" 10: 1-1/4" 16: 2"                                |   |   |   |
| 4 | E: External drain Omit: Internal drain  |   |   |   |
| 5 | Cracking pressure   |   |   |   |

## Specifications

Model			Max. Operating Pressure (bar)	Cracking Pressure (bar)	Rated Flow (lpm)	Weight(kg)		
Sub-Plate Mounting	Thread Connection	Flange Connection				G type	T type	F type
CPDG-03	CPDT-03	-	250	5: 0.5	50	5	3	-
CPDG-06	CPDT-06	-		35: 3.5	125	6.5	5.8	-
CPDG-10	CPDT-10	CPDF-10		50: 5	320	12	11.4	11.4
-	-	CPDF-16			500	-	-	30

## Dimensions

### CPDG-03, CPDG-06

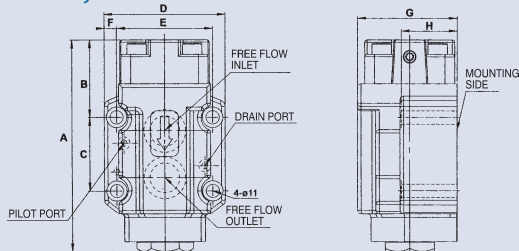

Model	A	B	C	D	E	F	G	H
CPDG-03	148	52.6	42.9	91	66.7	12.2	70	61
CPDG-06	174	63.4	60.3	100	79.4	10.3	82	46

### CPDG-10

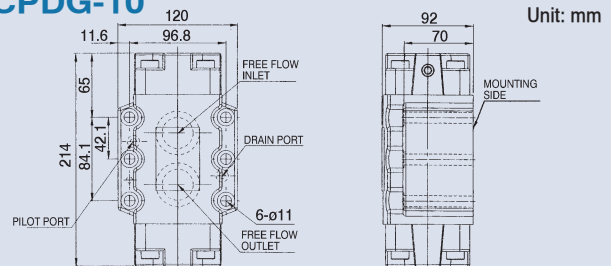

### CPDT-03,06,10

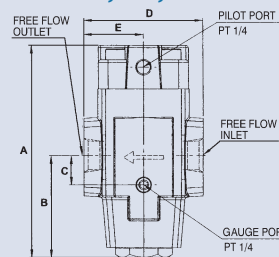

Model	A	B	C	D	E	F	G	H
CPDT-03	148	74	19	80	40	59	62	31
CPDT-06	174	84	24	98	49	72	75	37.5
CPDT-10	200	90.5	22.5	140	70	92.5	92	46

### CPDF-16

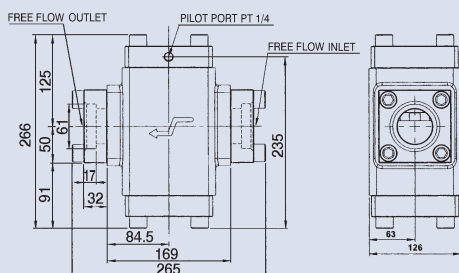

# IN-LINE PILOT OPERATED CHECK VALVE

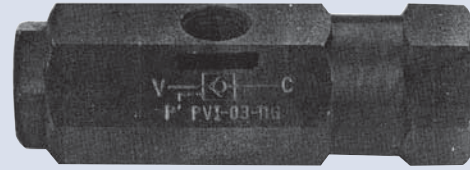
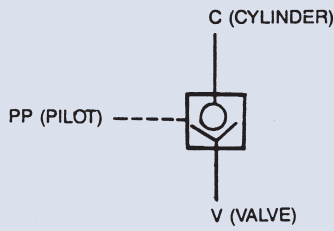

## How to order

### PCVI - 03 - T

- |   |                                    |
|---|------------------------------------|
| 1 | Model                              |
| 2 | Valve size 03: 3/8" 04: 1/2"       |
| 3 | Mounting type T: Thread connection |

## Specifications

Model	Max. Operating Pressure (bar)	Cracking Pressure (bar)	Max. Flow (lpm)	Weight (kg)
PCVI-03T	250	0.5	30	0.76
PCVI-04T			40	1.2

## Dimensions

### PCVI-03,04T

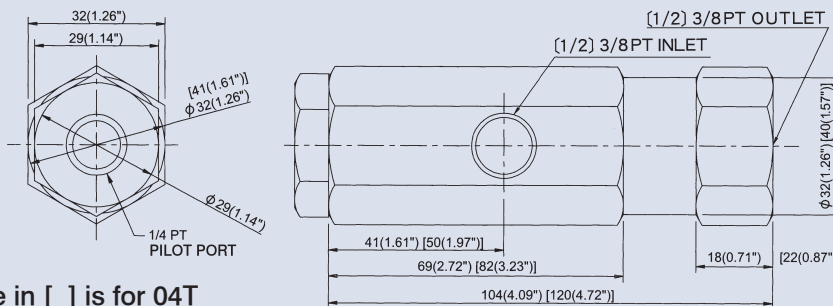

Unit: mm (inch)

Remark: The size in [ ] is for 04T

## Performance curves

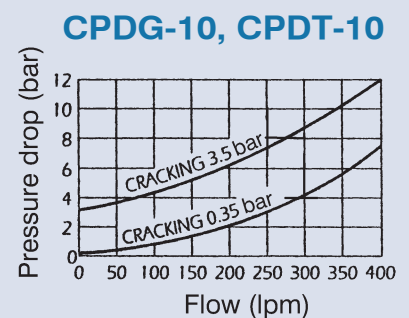
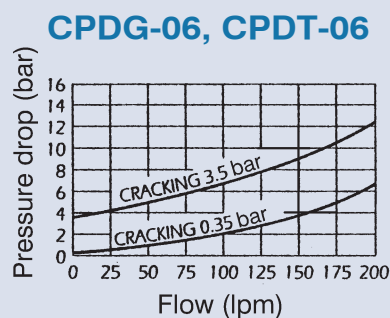
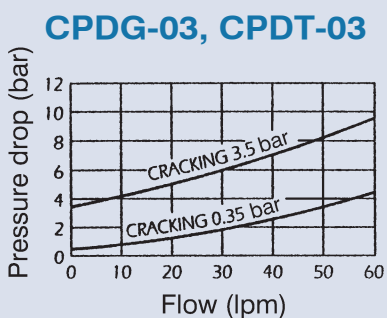



# PREFILL VALVE

## FEATURES:

- Material is FC30, Max. working pressure 3400psi.
- Both 180 and 90 degrees connection available.
- Min. pilot pressure required is 1/3 working pressure.
- Check operated in two stages to preclude shock.

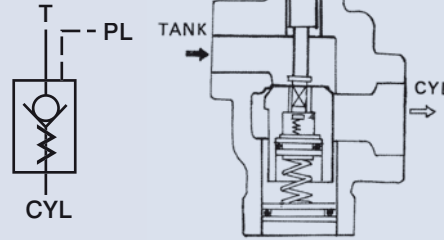

## How to order

### SG - 24 - ✱

1	2	3
1	Model	
2	Valve size	16: 2" 24: 3" 32: 4" 48: 6"
3	None: 180° L: 90°	

## Specifications

Model	Maximum Pressure (bar)	Max. Flow(lpm)		Operating Flow(lpm)		Cracking Pressure (bar)	Weight (kg)
		No Pilot	Pilot	No Pilot	Pilot		
SG-16	250	300	450	300 ± 70M	450 ± 70M	0.12	30
SG-24		600	900	600 ± 150M	900 ± 150M	0.14	55
SG-32		1100	1600	1100 ± 300M	1600 ± 300M	0.16	100
SG-48		2200	3200	2200 ± 600M	3200 ± 600M	0.16	240

## Dimensions

### SG-16, 24, 32, 48

Unit: mm

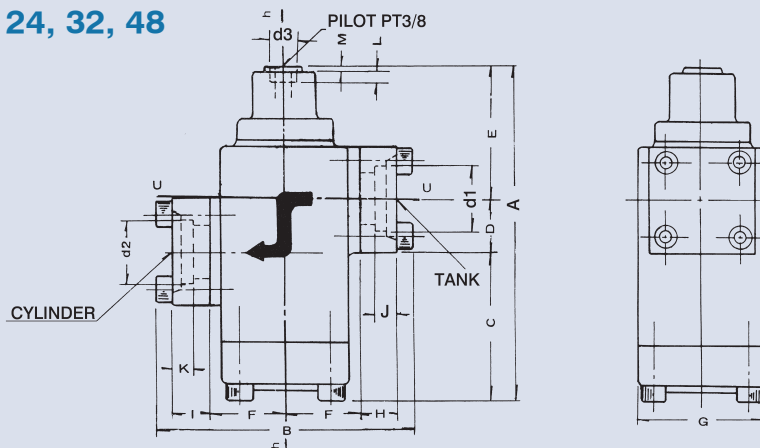

Model	A	B	C	D	E	F	G	H	I	J	K	L	M	d1	d2	d3
SG-16	322	242	136	53	133	70	120	35	24	20	20	21	12	61	61	PT 3/8
SG-24	396	294	168	90	160	92	150	30	44	13	21	28	12	95	95	PT 3/8
SG-32	556	358	215	96	255	120	194	30	44	28	28	25	12	116	138	28
SG-48	727	478	285	145	296	165	310	67	37	40	18	21	12	24	167	28

# FLANGE-CLAMPED TYPE PREFILL VALVE

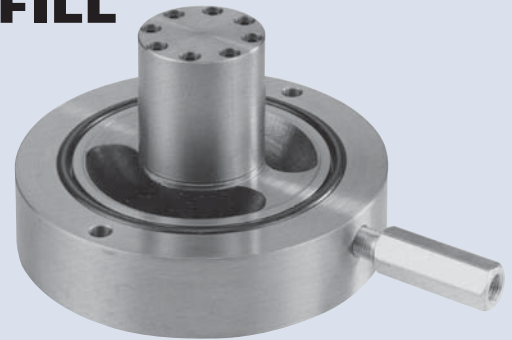
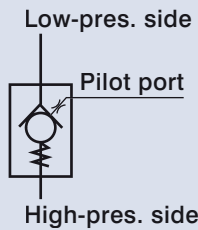

## How to order

### SVF - 100

1	Model	SVF: Steel body SCM4 (Max. 400 bar)	SCF: Ductile iron body FCD50 (Max. 250 bar)
2	Valve size		

## Specifications

Model	Port size Inch	Max. Flow (lpm)	Max. Operating Pressure (bar)	Pilot Ratio	Flange Bolts		Pipe size	Weight (kg)	
					Number	Nor. Diameter			
SVF-32	2	160	400	3.6	4	M16	2B	1.3	
SVF-40	2-1/2	250		3.3	4	M20	2.5B	2.2	
SVF-50	3	400		3.8	6	M16	3B	2.9	
SVF-63	3-1/2	630		4.2	8	M16	3.5B	4.5	
SVF-80	4	1000		4.3	8	M20	4B	6.2	
SVF-100	5	1600		4.3	10	M25	5B	12.3	
SVF-125	8	2500		4.3	16	M25	8B	23	
SVF-160	10	4000		4.2	16	M30	10B	50	
SVF-200	12	7000		4.1	20	M30	12B	85	
SVF-250	15	15000		4.4	24	M30	16B	156	
SCF-32	2	160		250	3.6	4	M16	2B	1.3
SCF-50	3	400			3.8	6	M16	3B	2.9
SCF-63	3-1/2	630	4.2		8	M16	3.5B	4.5	
SCF-80	4	1000	4.3		8	M20	4B	6.2	
SCF-100	5	1600	4.3		10	M25	5B	12.3	
SCF-125	8	2500	4.3		16	M25	8B	23	

## Dimensions / Performance curves

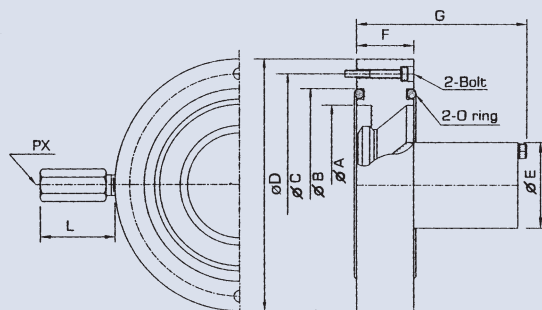

### Pilot port adaptor

Unit: mm

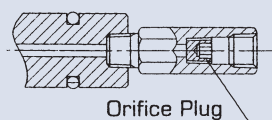

Model	Orifice	Plug
SVF (SCF)-32, 40, 50	0.7mm	PT1/8"
SVF (SCF)-63	0.8mm	
SVF (SCF)-80	1.0mm	PT1/4"
SVF (SCF)-100	1.2mm	
SVF (SCF)-125, 160	1.5mm	PT1/4"
SVF-200	1.8mm	

Model	øA	øB	øC	øD	øE	F	G	L	PX	Fixed bolt	O-ring		
SVF-32, SCF32	48	63	-	82	33	28	70	62	PT 1/4"	-	1517-6		
SVF-40	56.5	73	91	108	39	28	71.5			M4 x 30	1517-9		
SVF-50, SCF50	72	90	112	128	42	29	91			M4 x 30	1517-14		
SVF-63, SCF63	87	105	125	143	50	33.5	106			M5 x 35	P95		
SVF-80, SCF80	108	130.5	150	169	57	38.5	115			M5 x 40	P120		
SVF-100, SCF100	130	155	185	210	70	44	150			M6 x 45	P145		
SVF-125, SCF125	170	200	226	248	89	51	195			M6 x 60	P185		
SVF-160	218	250	284	310	120	70	230			70	PT 3/8"	M8 x 70	P235
SVF-200	272	310	355	390	145	95	300			85	PT 1/2"	M10 x 95	P295
SVF-250	350	398	445	490	176	110	390			85	PT 1/2"	M12 x 115	P375

### SVF(SCF)32-200

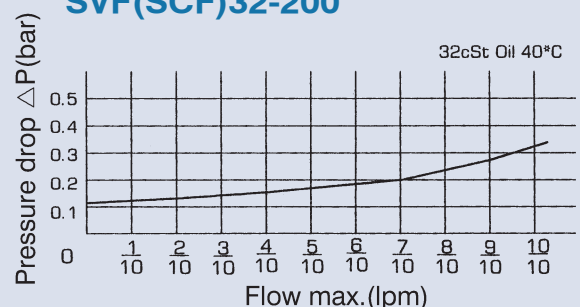

# FLANGE-CLAMPED TYPE PREFILL VALVE

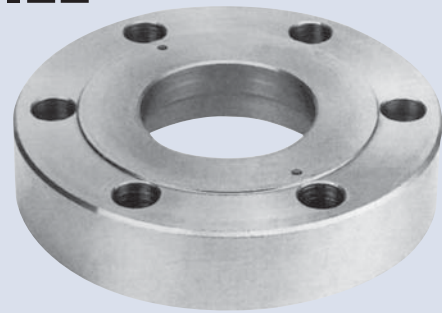

## How to order

### FGP - 100 - 2 - M25 - 5B

	1	2	3	4	5
1	Model	FGP: High-pres. Side flange	FGT: Low-pres. Side flange		
2	Valve size				
3	Pressure range	2: 250 bar	4: 400 bar		
4	Normal bolt size				
5	Normal pipe diameter				

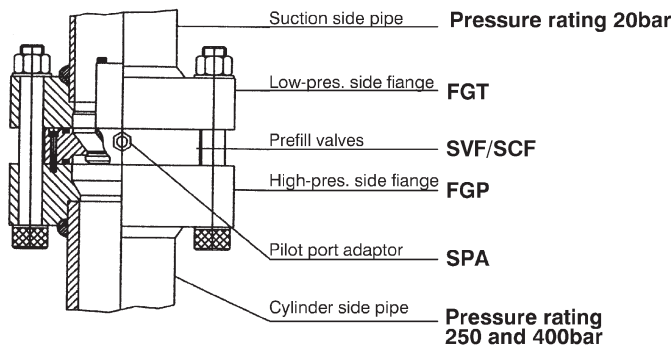

## Dimensions

### FGT

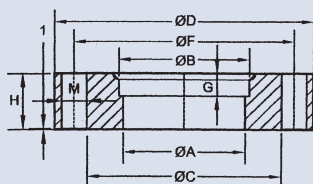

### FGP

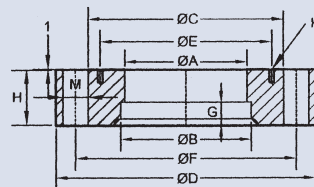

### FGT

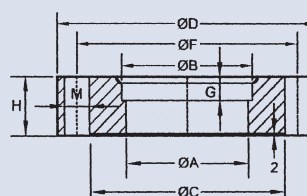

### FGP

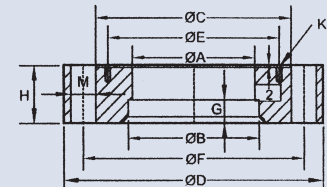

Unit: mm

Model	øD	øF	øB	øA	øE	øC	H	G	K	M
FGP-32-M16/2B FGT-32-M16/2B	135	103.2	60.25	48	-	82	33	15	-	4-ø18
FGP-40-M20/2.5B FGT-40-M20/2.5B	165	130	77	57	91	107	42	15	2-M4	4-ø22
FGP-50-M16/3B FGT-50-M16/3B	180	146	90	72	112	128	42	15	2-M4	6-ø18
FGP-63-M16/3.5B FGT-63-M16/3.5B	195	161	102.2	87	125	143	52/47	15	2-M5	8-ø18
FGP-80-M20/4B FGT-80-M20/4B	230	192	115.2	108	150	169	52/47	15	2-M5	8-ø22
FGP-100-M25/5B FGT-100-M25/5B	280	239	141	130	185	210	68/62	25	2-M6	10-ø27

Model	øD	øF	øB	øA	øE	øC	H	G	K	M
FGP-125-M25/8B FGT-125-M25/8B	352	300	219.2	168	226	249	77/67	25	2-M6	16-ø27
FGP-160-M30/10B FGT-160-M30/10B	422	367	273.1	218	284	311	87/77	30	2-M6	16-ø33
FGP-200-M30/12B FGT-200-M30/12B	510	442	324	270	355	391	97/87	30	2-M10	20-ø33
FGP-250-M30/16B FGT-250-M30/16B	630	555	407	350	445	492	107/97	30	2-M12	24-ø33

# FLANGE-CLAMPED TYPE PREFILL VALVE

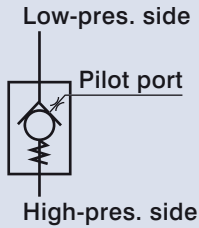

PF-80



PF-80F



## How to order

### PF - 80 - F - W

1	2	3	4
1	Model		
2	Valve size		
3	Mounting type	F: Flange None: Standard	
4	Flange type	None: No flange P: P port flange T: T port flange W: P&T port flange	

## Specifications

Model	Port Size (Inch)	Max. Operating Pressure (bar)	Max. Flow (lpm)	Cracking Pressure (bar)	Weight (kg)
PF-80 / PF-80F	3	250	400	0.12	2.8 / 8
PF-90 / PF-90F	3-1/2	250	630	0.12	3.8 / 11.3
PF-100 / PF-100F	4	250	1000	0.12	6 / 14.5
PF-125 / PF-125F	5	250	1600	0.12	10.8 / 23.8
PF-150 / PF-150F	6	250	2500	0.13	23.5 / 37
PF-200	8	250	4000	3	50

## Dimensions

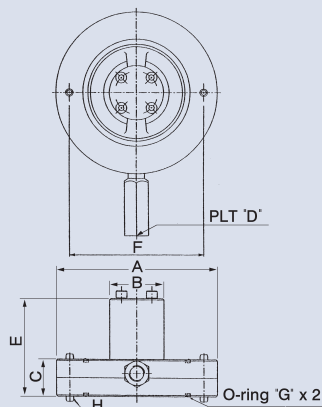

Model	A	B	C	D	E	F	G	H
PF-80	128	43	29	PT1/4	78	106	G80	6
PF-90	143	50	35	PT1/4	87	125	G100	6
PF-100	169	56	38.5	PT1/4	103	145	G115	6
PF-125	212	69	44	PT1/4	118	180	G140	6
PF-150	248	89	72	PT3/8	181	220	G180	10
PF-200	310	115	70	PT1/2	233	284	P235	10

### PF-80,90,100F

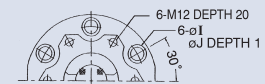

### PF-125F



### PF-150F

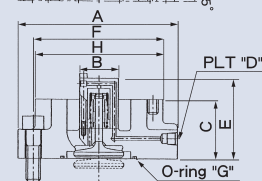
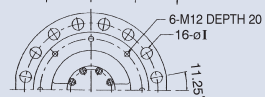

Model	A	B	C	D	E	F	G	H	I	J
PF-80F	180	43	65	PT1/4	94	146	G80	142	18	26
PF-90F	200	50	70	PT1/4	119	165	G100	160	20	29
PF-100F	230	56	71	PT1/4	132.5	191	G115	170	22	32
PF-125F	270	69	85	PT1/4	165	230	G140	200	22	-
PF-150F	300	91	105	PT3/8	204	260	G180	225	22	-

Unit: mm

# MANUALLY OPERATED DIRECTIONAL VALVE

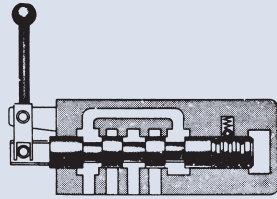
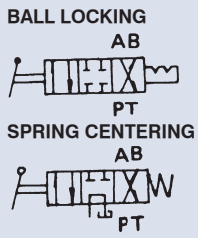

## How to order

### DM G - 02 - 3C6 - W

1	2	3	4	5
1	Model			
2	Mounting type	G: Sub-plate mounting	T: Thread connection	
3	Valve size			
4	Valve function Same as solenoidvalve DSG series			
5	Centered locking W: Spring centering O: Ball locking			

## Specifications

Model		Max. Operating Pressure(bar)	Max. Back Pressure (bar)	Max. Flow (lpm)	Weight (kg)		Bolt size DMG
Sub-Plate Mounting	Thread Connection				DMG	DMT	
DMG-02	-	250	140	40	1.5	1.5	M5 x 45L
DMG-03	DMT-03		100	70	3.3	4	M6 x 35L
-	DMT-04		140	350	-	7.5	-
DMG-06	DMT-06				500	12.5	12
-	DMT-10				-	23	-

## Dimensions

### DMT-03,04,06,10

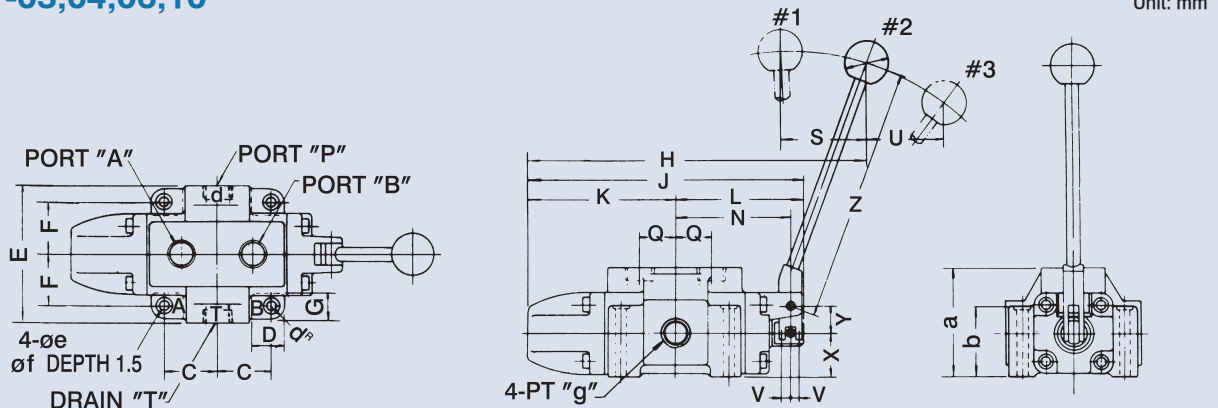

Model	C	D	E	F	G	H	J	K	L	N	Q	S	U	V	X	Y	Z	a	b	d	e	f	g(pT)
DMT-03	27	18	74	23	10	246	170	90	80	73.5	23	46	42	5	41	22	200	84.5	74	6	6M	-	3/8
DMT-04	45	33	109	40.5	18	280	222	116	106	96	25	75	60	10	37	19	240	90	55	9	9	14	1/2
DMT-06	50	30	130	49	20	320	255	137	118	107	33.5	86	76	9	40	25	250	100	65	12	11	17.5	3/4
DMT-10	67	40	162	62.5	33	402	320	173	147	135	40	102	90	12.5	50	35	270	124	82	15	13.5	21	1-1/4

# MANUALLY OPERATED DIRECTIONAL VALVE

## Dimensions

### DMG-02 (ISO CETOP 3, NFPA D03, DIN NG 6)

Unit: mm  
(inch)

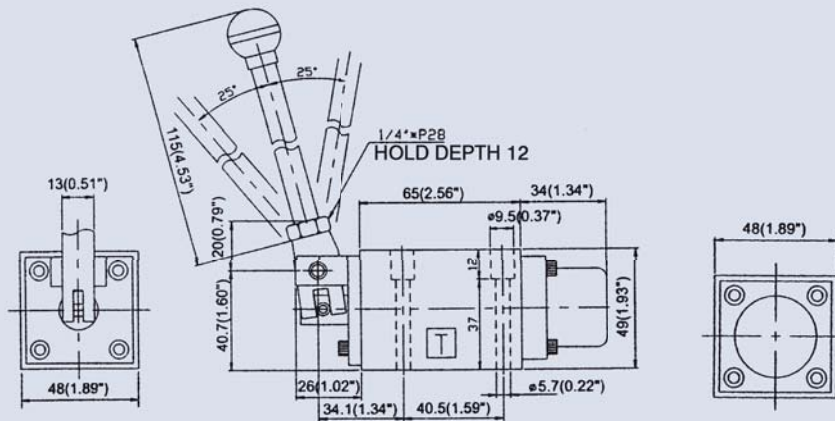

### DMG-03G (ISO CETOP 5, NFPA D05, DIN NG 10)

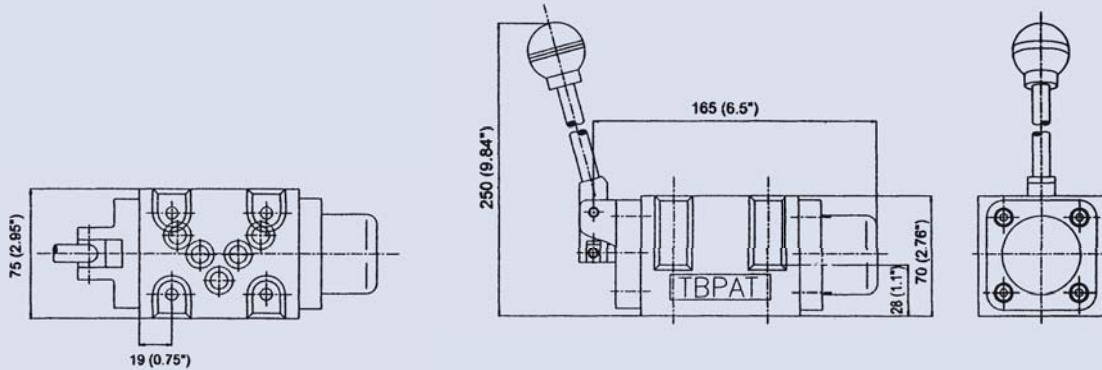

### DMG-06 (ISO CETOP 8, NFPA D08, DIN NG 25)

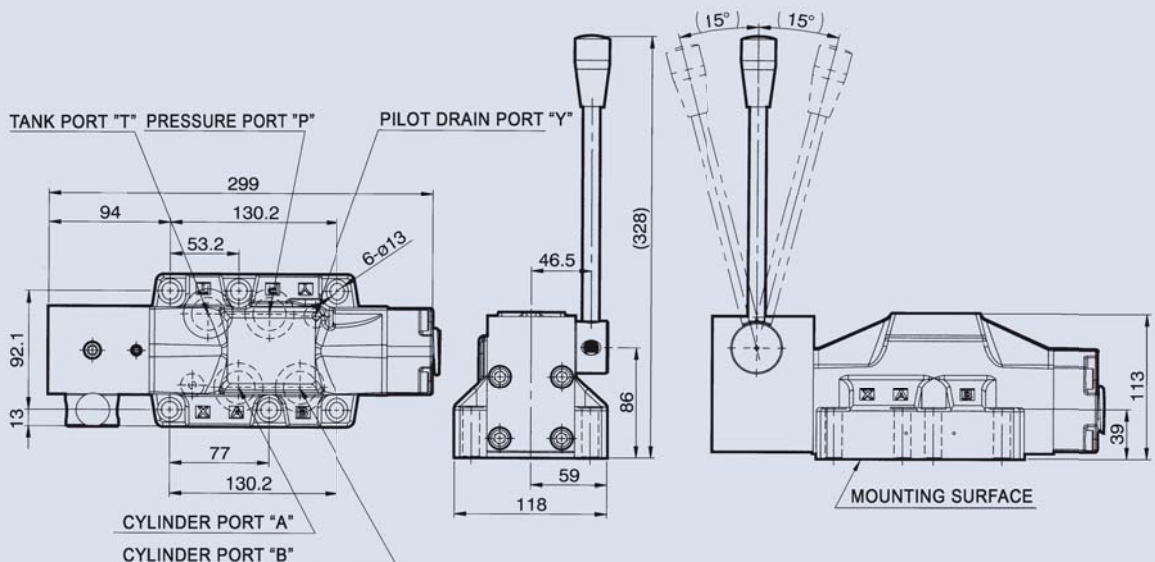



# MANUALLY OPERATED DIRECTIONAL VALVE

HV-03T

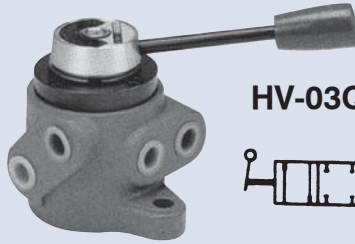

HV-03QT



DGH-T03

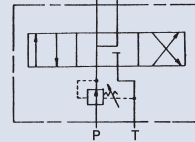

## Specifications

Model	Port size (PT)	Max. Pressure (bar)	Flow rated (lpm)	Weight (kg)
HV-03T	3/8"	100	50	3.1
HV-03QT	3/8"	100	30	2.62
DGH-T03	1/4"	70	20	2.8

## Dimensions

HV-03T

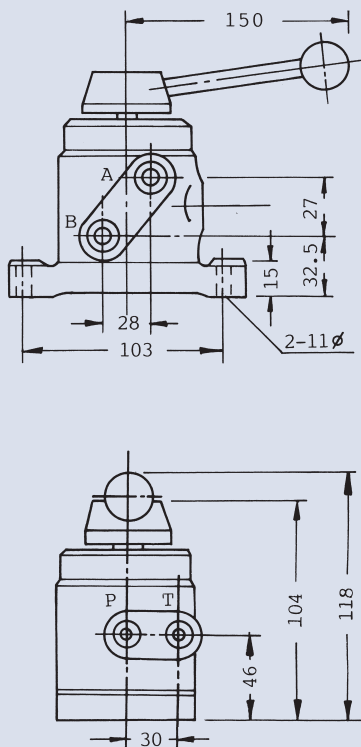

HV-03QT

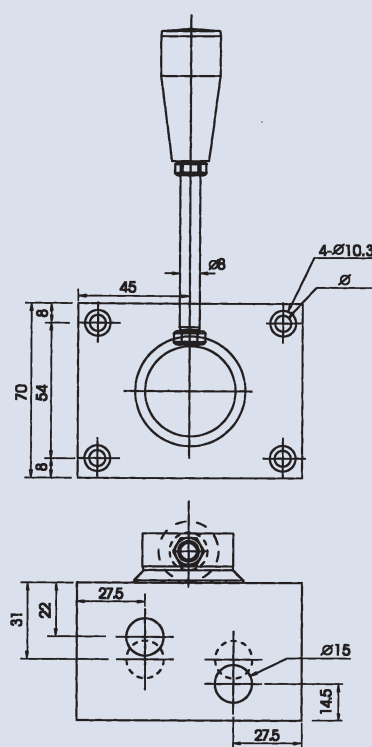

DGH-T03

Unit: mm

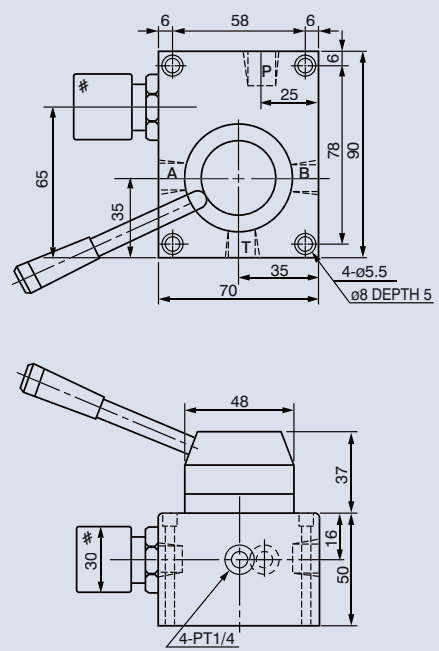



# MANUALLY OPERATED DIRECTIONAL VALVE

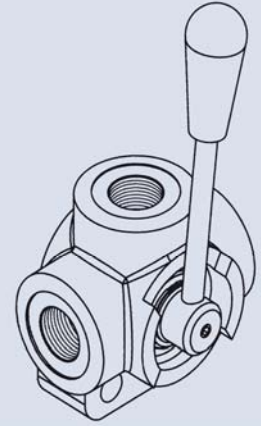
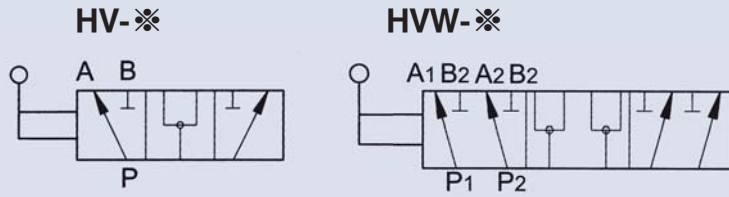

## How to order

### HV HVW - 380

1 2

1	Model	HV single lever	HVW double lever
2	Valve size	380: G3/8"	120: G1/2" 340: G3/4" 100: G1"

## Specifications

Model	Max. Pressure (bar)	Max. Flow (lpm)	Weight (kg)	
			HV	HVW
HV HVW -380	315	50	1.4	2.8
HV HVW -120	280	80		
HV HVW -340	220	120	1.8	3.6
HV HVW -100	220	180		

## Dimensions

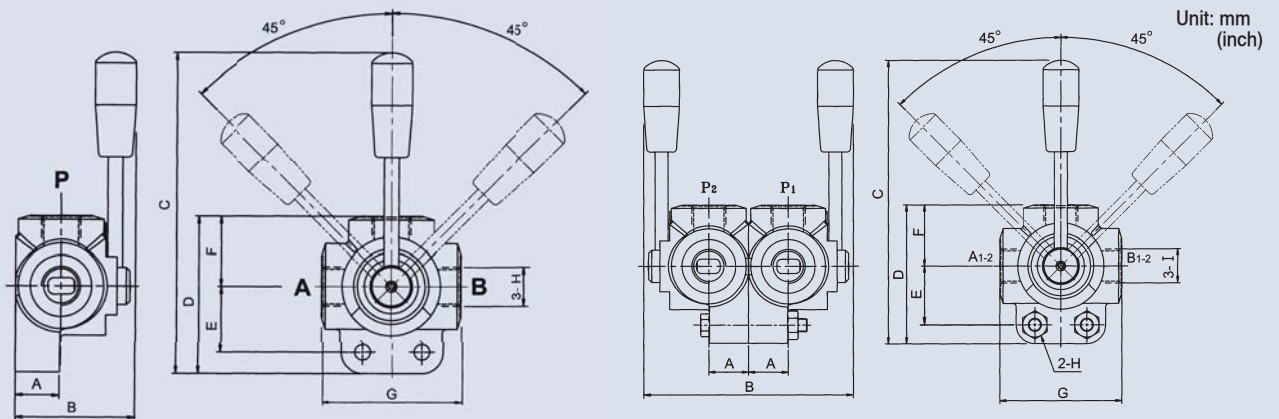

Model Size	HV-380	HV-120	HV-340	HV-100
A	24 (0.95")		26.5 (1.04")	
B	64.5 (2.54")		68.1 (2.68")	
C	173.4 (6.83")		180.7 (7.11")	
D	85 (3.35")		99.4 (3.91")	
E	36 (1.42")		42 (1.65")	
F	37.5 (1.47")		44.6 (1.77")	
G	75 (2.95")		90 (3.54")	
H	G3/8	G1/2	G3/4	G1

Model Size	HVW-380	HVW-120	HVW-340	HVW-100
A	24 (0.95")		26.5 (1.04")	
B	128.9 (5.08")		136.3 (5.37")	
C	173.4 (6.83")		180.7 (7.11")	
D	85 (3.35")		99.4 (3.91")	
E	36 (1.42")		42 (1.65")	
F	37.5 (1.47")		44.6 (1.76")	
G	75 (2.95")		90 (3.54")	
H	M8		M10	
I	G3/8	G1/2	G3/4	G1

# SERVO CONTROL VALVE

## FEATURES:

- Servo control accuracy up to  $\pm 0.005\text{mm}$ .
- Actuated by hydraulic system.
- The unit is applicable for plano-miller, milling machine, etc.
- Precision structure. Long service life.
- Various models for choice.

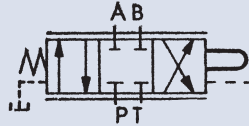

## How to order

### SA - G 03

1 2 3

- |   |               |                               |                                   |
|---|---------------|-------------------------------|-----------------------------------|
| 1 | Model         | SA: With cover and long shaft | SB: Without cover and short shaft |
| 2 | Mounting type | G: Sub-plate mounting         |                                   |
| 3 | Valve size    |                               |                                   |

## Specifications

Model	Max. Pressure (bar)	Oper. Pressure (bar)	Max. Back Pressure (bar)	Spool Shift mm	Max. Flow (lpm)	Weight (kg)
SA, SB-G02	70	12~15	20	$\pm 2$	70	2.5
SA, SB-G03					90	3.5
SA, SB-G04					110	4.5

## Examples of copy machining

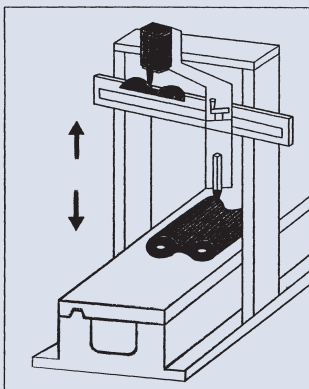

The servo control valve operated on a planomiller.

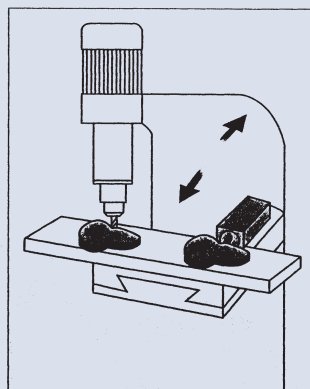

The servo control valve operated on a milling machine.

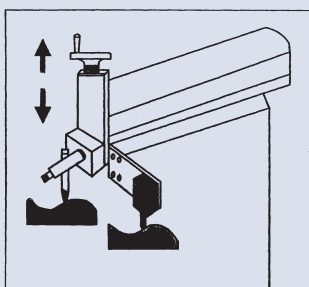

The servo control valve operated on a shaping machine.

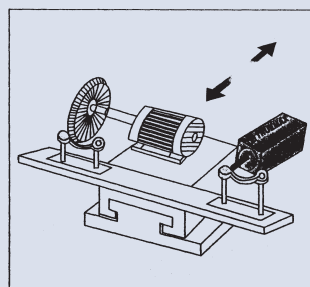

The servo control valve operated on a special purpose polishing machine.

### Basic hydraulic circuit

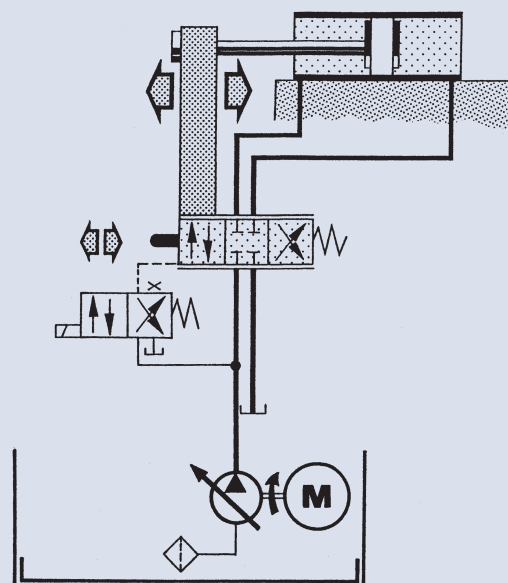



# CAM OPERATED DIRECTIONAL VALVE

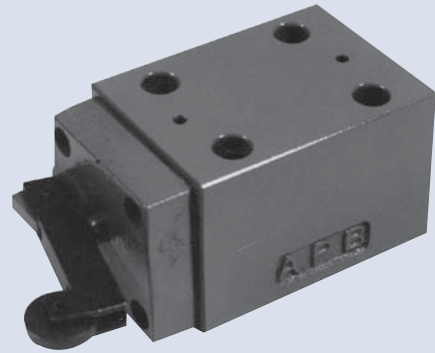

## How to order

### DC G - 01 - 2B2

1	2	3	4
1	Model		
2	Mounting type G: Sub-plate mounting T: Thread connection		
3	Valve size DCG-01: 1/8" (ISO CETOP 3, NFPA D03, DIN NG 6) DCT-01: PT 1/8"		
4	Spool type 2B2 2B3 2B8		

## Specifications

Model		Max. Operating Pressure(bar)	Rated Flow (lpm)	Weight (kg)	Bolt Size
Sub-Plate Mounting	Thread Connection				
DCG-01	DCT-01	250	30	1.2	M5 x 50L

## Dimensions

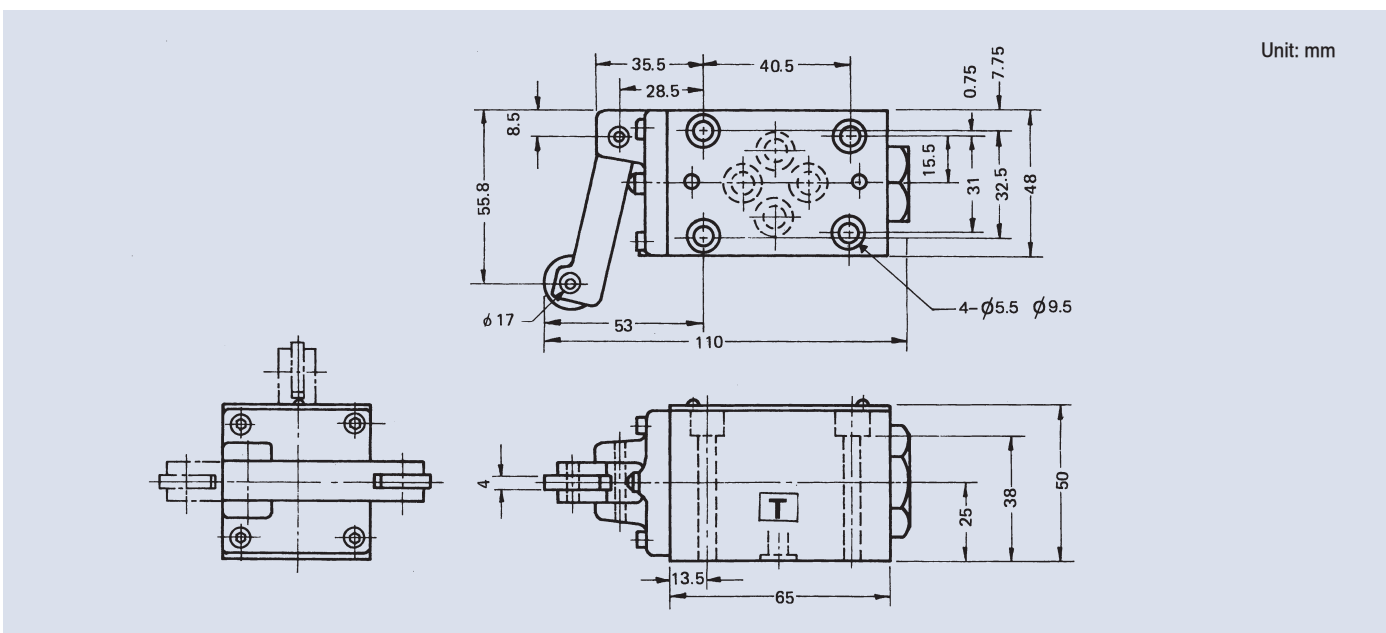

# SOLENOID OPERATED DIRECTIONAL VALVE

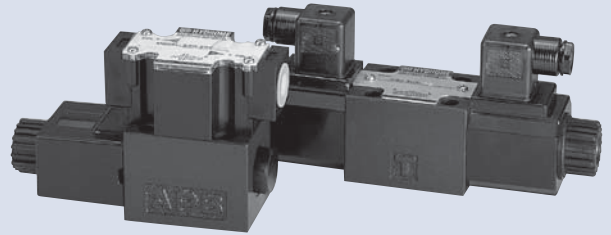
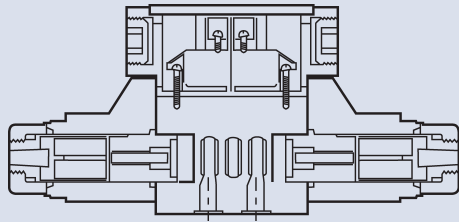

## How to order

### DSG - 02 - 3C2 - A2 - N

	1	2	3	4	5
1	Model				
2	Nominal valve size 1/4" (ISO CETOP 3, NFPA D03, DIN NG 6)				
3	Spool type				
4	Coil voltage A11: AC110V (50/60HZ) A22: AC220V (50/60HZ) A24: AC240V (50HZ) A38: AC380V (50HZ) D1: DC12V D2: DC24V R1: R110V (50/60HZ) R2: R220V (50/60HZ)				
5	No symbol: Joint box type N: Din connector type				

## Specifications

ITEM	Model Numbers	Spool Type	Rated Flow lpm (gpm)	
			AC / DC / R	Max. Flow lpm (gpm)
1	DSG-3C2		50 (13.2)	70 (18.5)
2	DSG-3C4			
3	DSG-3C5		30 (7.9)	70 (18.5)
4	DSG-3C10			
5	DSG-3C60		30 (7.9)	50 (13.2)
6	DSG-3C3			
7	DSG-2D2			
8	DSG-2D3		40 (10.6)	50 (13.2)
9	DSG-2B3			
10	DSG-2B2		40 (10.6)	70 (18.5)
11	DSG-2B8			

# SOLENOID OPERATED DIRECTIONAL VALVE

## Dimensions

### DSG-02-AC

Unit: mm  
(inch)

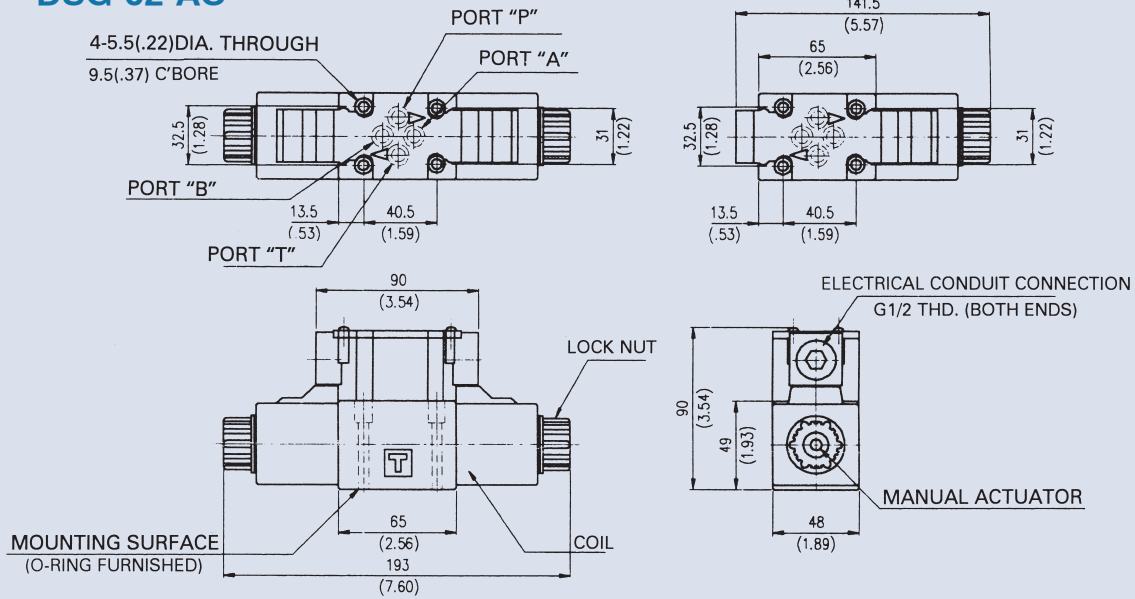

Parts name	Description	Tightening torque
Attachment SOC. HD. cap screw	M5 x 45Lg x 4pcs	5~7Nm
Attachment SOC. HD. cap screw	10-24UNC x 1-3/4"Lg x 4pcs	43~60in. lbs

### DSG-02-DC/RAC

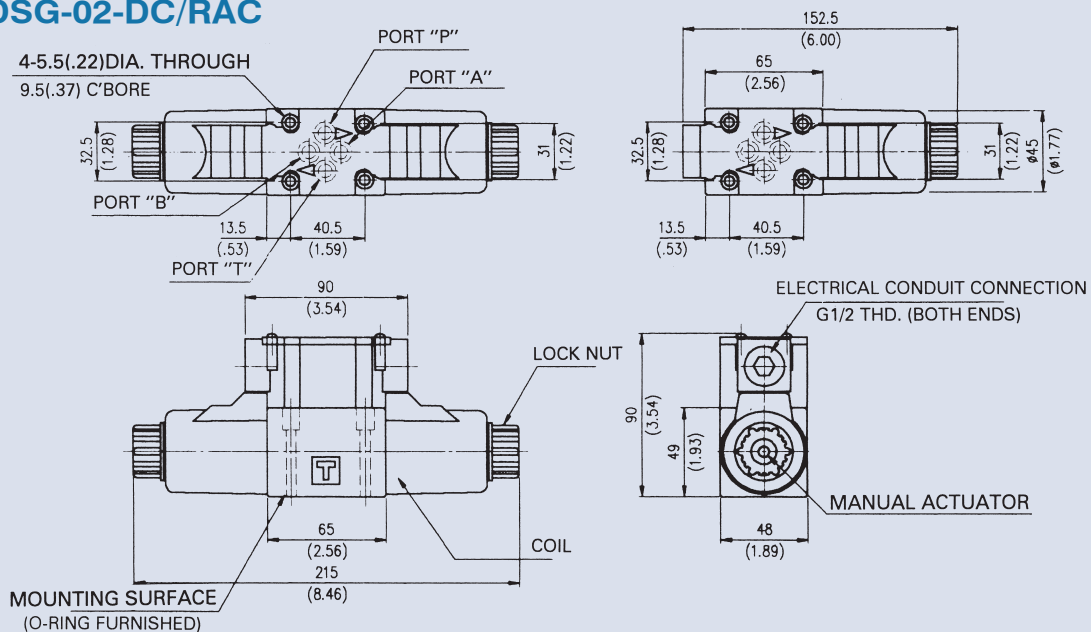

Parts name	Description	Tightening torque
Attachment SOC. HD. cap screw	M5 x 45Lg x 4pcs	5~7Nm
Attachment SOC. HD. cap screw	10-24UNC x 1-3/4"Lg x 4pcs	43~60in. lbs

# SOLENOID OPERATED DIRECTIONAL VALVE

## Dimensions

### DSG-02-AC-N

Unit: mm  
(inch)

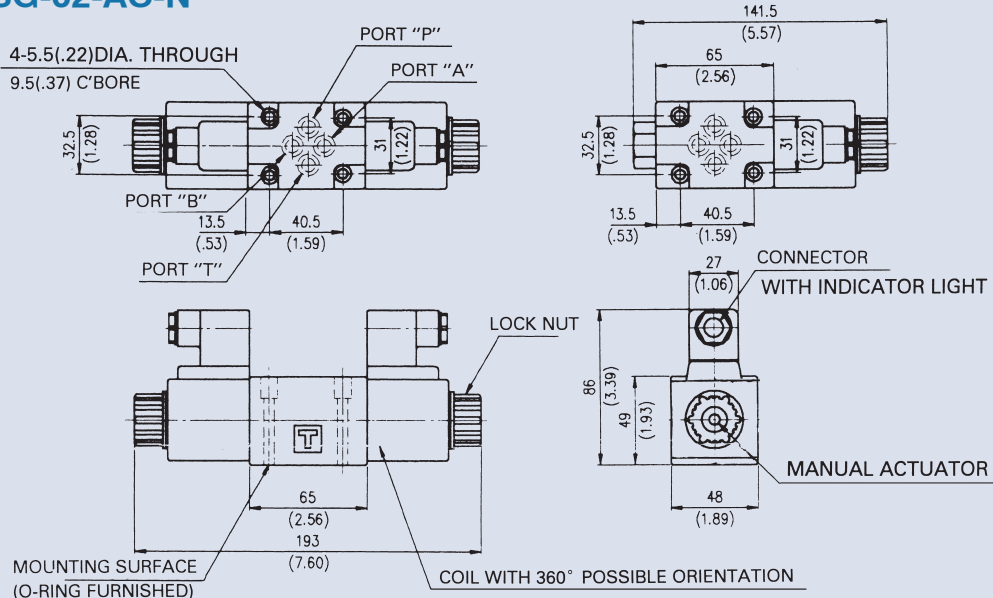

Parts name	Description	Tightening torque
Attachment SOC. HD. cap screw	M5 x 45Lg x 4pcs	5~7Nm
Attachment SOC. HD. cap screw	10-24UNC x 1-3/4"Lg x 4pcs	43~60in. lbs

### DSG-02-DC/RAC-N

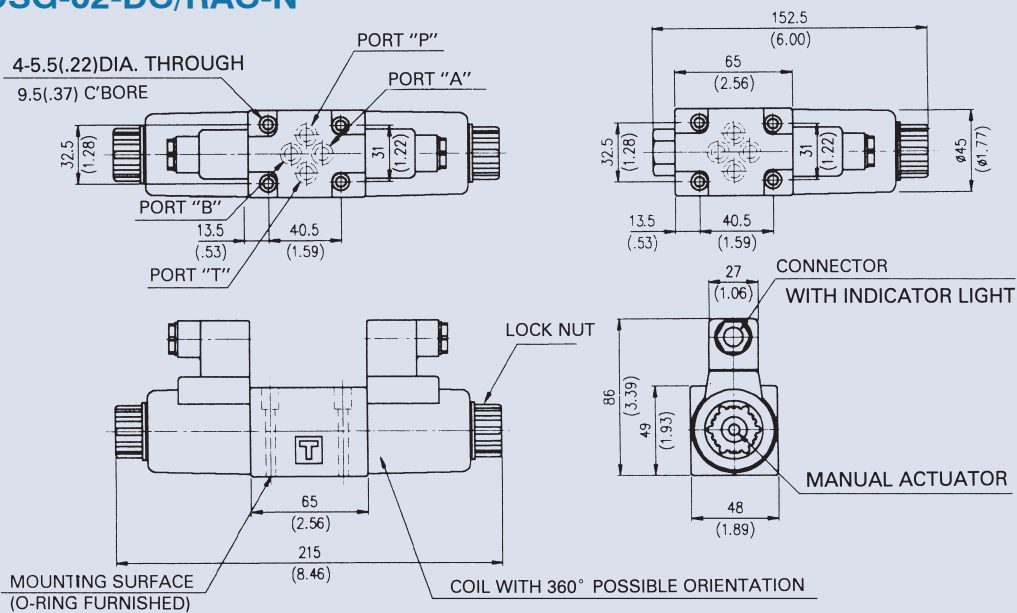

Parts name	Description	Tightening torque
Attachment SOC. HD. cap screw	M5 x 45Lg x 4pcs	5~7Nm
Attachment SOC. HD. cap screw	10-24UNC x 1-3/4"Lg x 4pcs	43~60in. lbs



# SOLENOID OPERATED DIRECTIONAL VALVE

## FEATURES:

- Plug-in solenoids for easier to change to coils.
- Easier maintenance with all spools and bodies are interchangeable by keeping the same limitation of internal leakage.
- Low noise level while all the movable parts are submerged in the working oil cushion impact reduces the operation noise.
- High voltage test up to 1500 v/min.
- Insulation resistance exceeds 100MΩ.
- Momentary signal for shifting action at approx. 0.1 second.
- Longer service life for durability to 30,000,000 spool shifts.
- High class insulation coil for high temperature resistance up to 180 °C.

## Specifications

Max. pressure	P.A.B.	315 bar (4600psi)	
Max. back pressure	T	70~160 bar (1400~2300psi)	
Weight kg (lb)	Single solenoid	AC 1.5 (3.3)	DC(R) 1.6 (3.5)
	Double solenoid	AC 1.85 (4)	DC(R) 2 (4.4)
Maximum frequency of operation (cycle/min)		150	
Ambient temperature range recommended		5~60 °C (67~166 °F)	
Using oil (cst)		20~300	
Filtration (micron)		25	

## Performance curves

### Performance chart

	P→A	P→B	A→T	B→T	P→T
3C2	③	③	③	③	—
3C3	①	①	③	③	④
3C4	③	③	①	①	—
3C5	①	⑥	③	⑤	④
3C60	⑥	⑥	⑤	⑤	④
3C10	③	③	③	①	—
2D2	②	②	⑤	⑤	—
2D3	①	①	③	③	—
2B2	②	②	⑤	⑤	—
2B3	④	③	①	④	—

Test fluid viscosity: 35 cst  
Test temperature: 50 °C (122 °F)

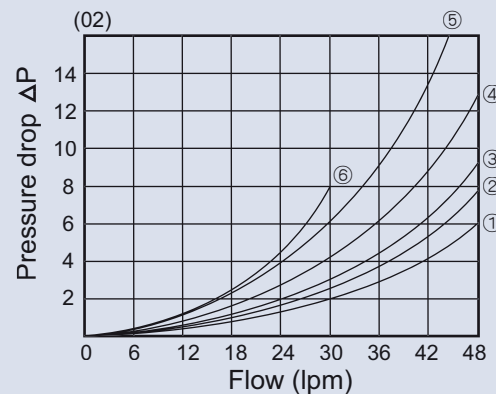

# SOLENOID OPERATED DIRECTIONAL VALVE

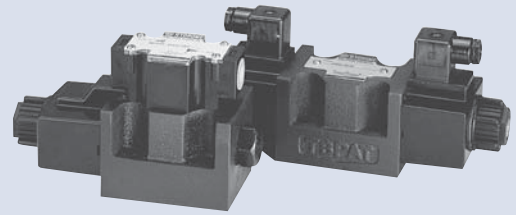
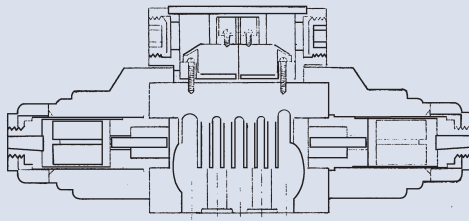

## How to order

### DSG - 03 - 3C2 - A2 - N

1      2      3      4      5

- 1 Model
- 2 Nominal valve size 3/8" (ISO CETOP 5, NFPA D05, DIN NG 10)
- 3 Spool type
- 4 Coil voltage A11: AC110V (50/60HZ) A22: AC220V (50/60HZ) A24: AC240V (50HZ) A38: AC380V (50HZ) D1: DC12V D2: DC24V  
R1: R110V (50/60HZ) R2: R220V (50/60HZ)
- 5 No symbol: joint box type N: Din connector type

ITEM	Model Numbers	Spool Type	Rated Flow lpm (gpm)	
			AC / DC / R	Max. Flow lpm (gpm)
1	DSG-3C2		70 (18.5)	120 (31.7)
2	DSG-3C4			
3	DSG-3C5			
4	DSG-3C10			
5	DSG-3C60		50 (13.2)	80 (21.1)
6	DSG-3C3			
7	DSG-2D2			
8	DSG-2D3		70 (18.5)	120 (31.7)
9	DSG-2B3			
10	DSG-2B2			
11	DSG-2B8		70 (18.5)	120 (31.7)

# SOLENOID OPERATED DIRECTIONAL VALVE

## Dimensions

### DSG-03-AC

Unit: mm  
(inch)

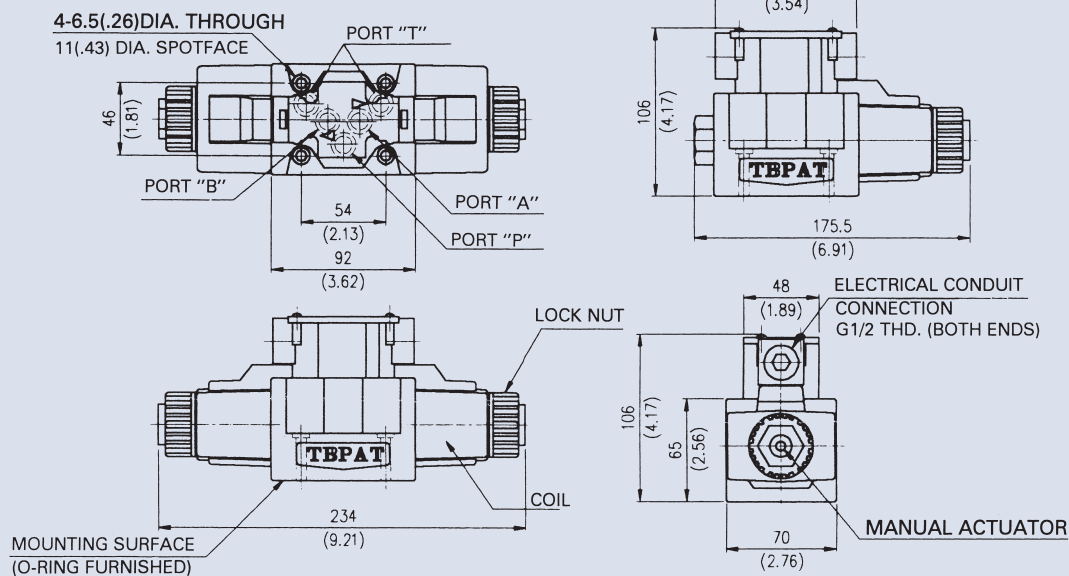

Parts name	Description	Tightening torque
Attachment SOC. HD. cap screw	M6 x 35Lg x 4pcs	12~15Nm
Attachment SOC. HD. cap screw	1/4-20UNC x 1-1/2"Lg x 4pcs	105~130in. lbs

### DSG-03-DC/RAC

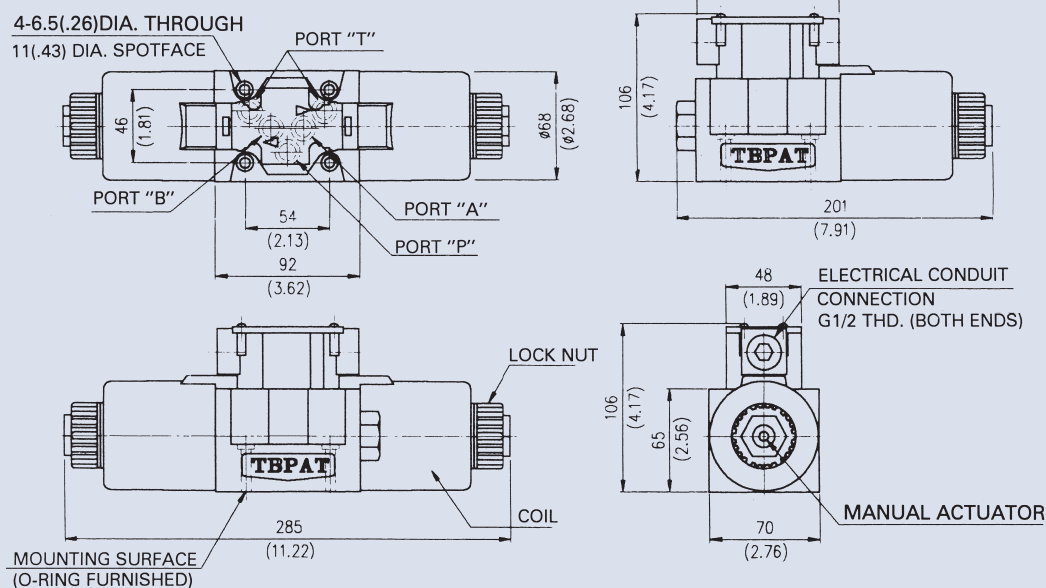

Parts name	Description	Tightening torque
Attachment SOC. HD. cap screw	M6 x 35Lg x 4pcs	12~15Nm
Attachment SOC. HD. cap screw	1/4-20UNC x 1-1/2"Lg x 4pcs	105~130in. lbs

# SOLENOID OPERATED DIRECTIONAL VALVE

## Dimensions

### DSG-03-AC-N

Unit: mm  
(inch)

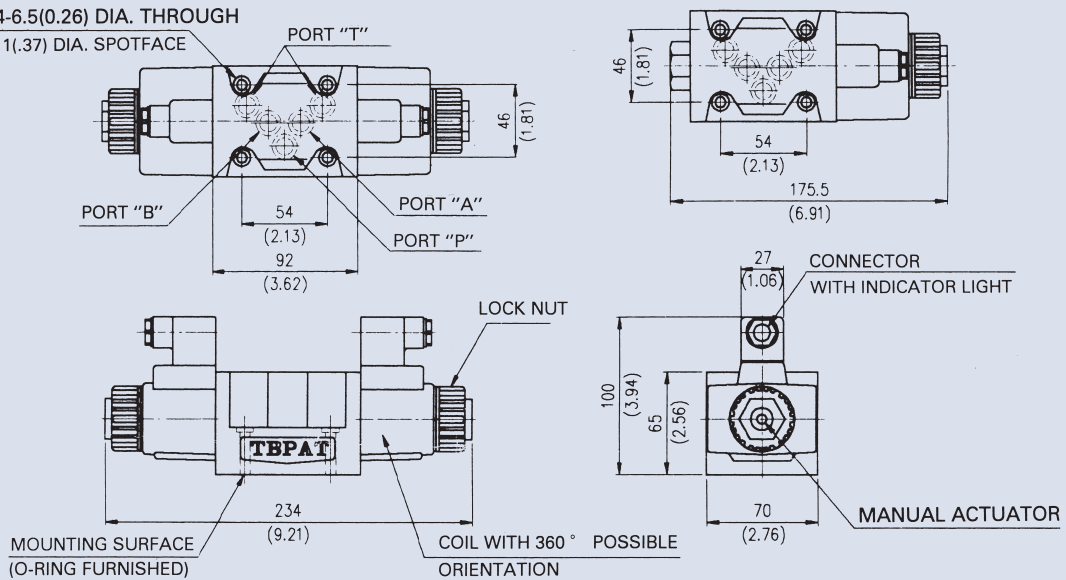

Parts name	Description	Tightening torque
Attachment SOC. HD. cap screw	M6 x 35Lg x 4pcs	12~15Nm
Attachment SOC. HD. cap screw	1/4-20UNC x 1-1/2"Lg x 4pcs	105~130in. lbs

### DSG-03-DC/RAC-N

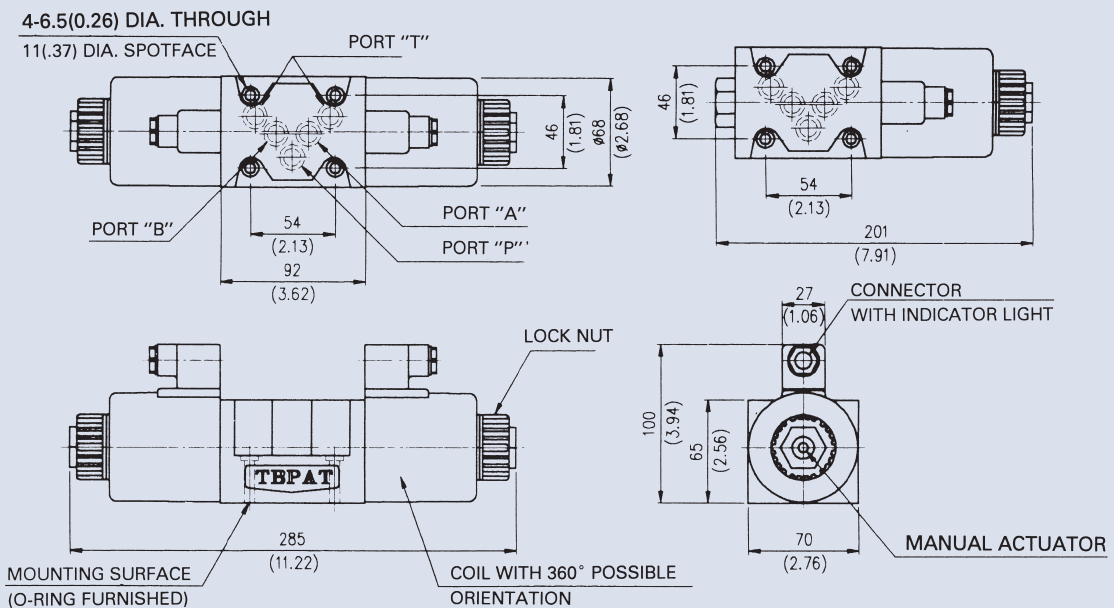

Parts name	Description	Tightening torque
Attachment SOC. HD. cap screw	M6 x 35Lg x 4pcs	12~15Nm
Attachment SOC. HD. cap screw	1/4-20UNC x 1-1/2"Lg x 4pcs	105~130in. lbs

# SOLENOID OPERATED DIRECTIONAL VALVE

## Specifications

Max. pressure	P.A.B.	315 bar (4600psi)	
Max. back pressure	T	70~160 bar (1400~2300psi)	
Weight kg (lb)	Single solenoid	AC 3.3 (7.3)	DC (R) 3.7 (8.2)
	Double solenoid	AC 4 (8.8)	DC (R) 4.8 (10.6)
Maximum frequency of operation (cycle/min)		150	
Ambient temperature range recommended		5~60 °C (67~166 °F)	
Using oil (cst)		20~300	
Filtration (micron)		25	

## Performance curves

### Performance chart

	P→A	P→B	A→T	B→T	P→T
3C2	③	③	③	③	—
3C3	①	①	③	③	④
3C4	③	③	①	①	—
3C5	①	⑥	③	⑤	④
3C60	⑥	⑥	⑤	⑤	④
3C10	③	③	③	①	—
2D2	②	②	⑤	⑤	—
2D3	①	①	③	③	—
2B2	②	②	⑤	⑤	—
2B3	④	③	①	④	—

Test fluid viscosity: 35 cst  
Test temperature: 50 °C (122 °F)

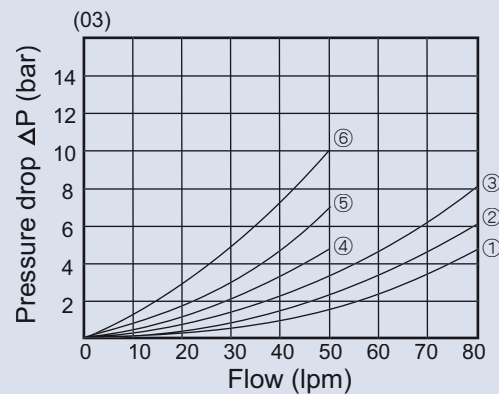

### Electrical wirings

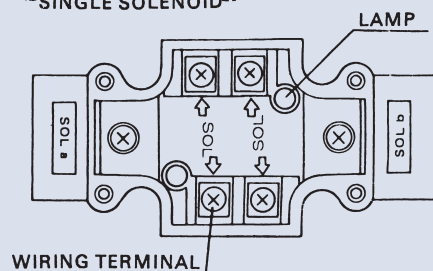
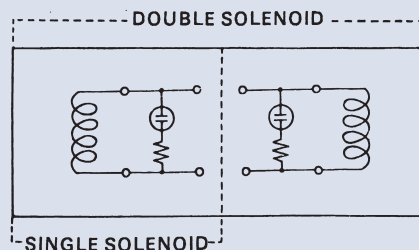

### Technical data

Current AC/DC	AC				DC	
Frequency (Hz)	50	60	50	60	—	—
Rating voltage (V)	110	110	220	220	12	24
(01) 1/4	In-rush current	2.7	2.3	1.4	1.2	2
	Holding current	0.45	0.38	0.23	0.19	
(03) 3/8"	In-rush current	4.8	4.4	2.4	2.1	3.0
	Holding current	0.79	0.72	0.39	0.34	
DSG 01R	In-rush current	0.5	0.5	0.25	0.25	—
	Holding current	0.35	0.35	0.18	0.18	
DSG 03R	In-rush current	0.66	0.66	0.33	0.33	—
	Holding current	0.45	0.45	0.28	0.28	
Permissible voltage (V)	Rating voltage +10% or -15%					
Insulation resistance (MΩ)	More than 100MΩ (DC 500V insulation tester)					

# PILOT OPERATED DIRECTIONAL VALVE

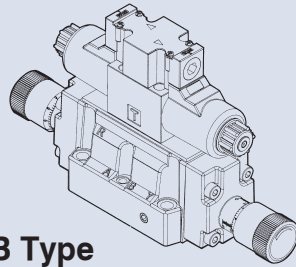

AB Type

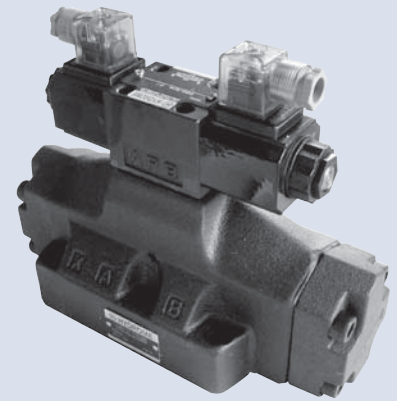

## How to order

### DSHG - 06 - 3C2 - AB - E - T - A1

1	2	3	4	5	6	7
1	Model					
2	Nominal valve size	03: 3/8" (ISO CETOP 5, NFPA D05, DIN NG 10) 06: 3/4" (ISO CETOP 8, NFPA D08, DIN NG 25)	04: 1/2" (ISO CETOP 7, NFPA D07, DIN NG 16) 10: 1-1/4" (ISO CETOP 10, NFPA D10, DIN NG 32)			
3	Spool type					
4	AB: With stroke adjusting both ends    A: With stroke adjusting port A    B: With stroke adjusting port B					
5	E: External pilot    Omit: Internal pilot					
6	T: Internal drain    Omit: External drain					
7	Voltage	A11: AC110V (50/60HZ)    R1: R110V (50/60HZ)	A22: AC220V (50/60HZ)    R2: R220V (50/60HZ)	A24: AC240V (50HZ)	A38: AC380V (50HZ)	D1: DC12V    D2: DC24V

## Dimensions

### DSHG-03

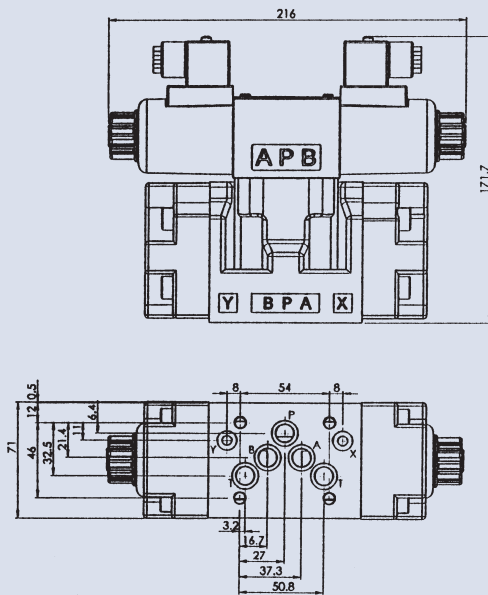

### DSHG-04, 06, 10

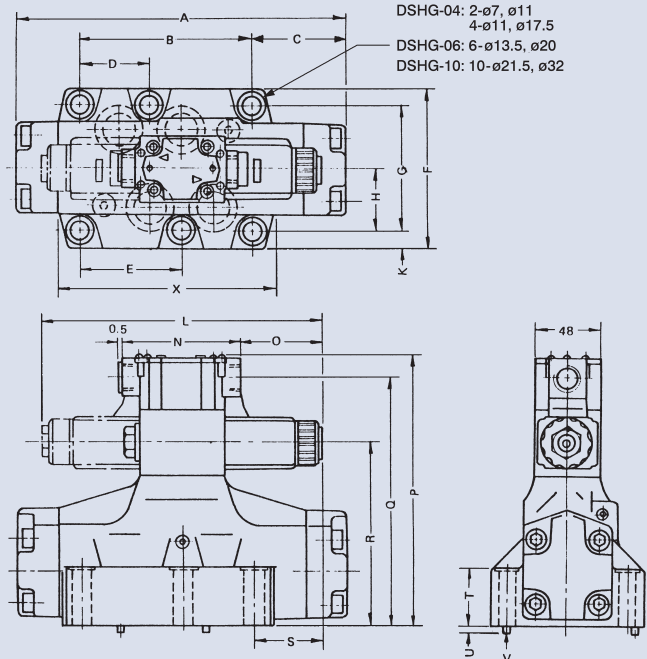









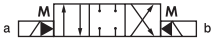

Unit: mm

Model	A	B	C	D	E	F	G	H	K	L	N	O	P	Q	R	S	T	U	V	X
DSHG-04	204	101.6	50.4	34	50	91	69.8	-	9	215	90	60	180.3	163	116	53.4	35	4	2-ø3	-
DSHG-06	255	130.2	74.3	53.2	77	118	92.1	46.1	13	215	90	60	201.5	184	137	51.3	41	6	2-ø6	156
DSHG-10	384	190.5	116	76.2	114.3	198	158.8	79.4	19.6	215	90	60	264.5	247	200	28.5	45	6	2-ø6	233.8

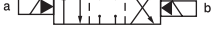
# PILOT OPERATED DIRECTIONAL VALVE

## Specifications

Model Numbers		DSHG-03		DSHG-04		DSHG-06		DSHG-10		
ITEM	Model Numbers	Spool Type	Rated Flow (lpm)	Max. Flow (lpm)	Rated Flow (lpm)	Max. Flow (lpm)	Rated Flow (lpm)	Max. Flow (lpm)	Rated Flow (lpm)	Max. Flow (lpm)
1	DSHG-3C2		90	160	135	300	310	500	570	1100
2	DSHG-3C4		90	160	135	300	310	500	570	1100
3	DSHG-3C5		90	160	245	280	230	450	570	950
4	DSHG-3C10		90	160	135	300	310	500	570	1100
5	DSHG-3C6		90	160	245	280	230	450	570	950
6	DSHG-3C3		90	160	135	300	230	450	570	950
7	DSHG-2D2		90	160	135	300	310	500	570	1100
8	DSHG-2D3		90	160	135	300	310	500	570	1100
9	DSHG-2B3		90	160	245	280	230	450	570	950
10	DSHG-2B2		90	160	245	280	230	450	570	950
11	DSHG-3C9		90	160	245	280	230	450	570	950
Max. pressure		P.A.B.	315 bar (4600 psi)							
Max. back pressure		T	70~160 bar (1400~2300 psi)							
Weight kg (lb)		Single solenoid	6.4 (14.08)		7.6 (16.72)		13.3 (29.26)		51.6 (113.52)	
		Double solenoid	6.9 (15.18)		8 (17.6)		13.7 (30.14)		52 (114.40)	
Maximum frequency of operation (cycle/min)		120								
Ambient temperature range recommended		5~60 °C (67~166 °F)								
Using oil (cst)		20~300								
Filtration (micron)		25								



# SPOOL FUNCTION TABLE

## Specifications

Three Position Spring Center	Standard Type	Two Position No Spring	Standard Type	Two Position No Spring	Standard Type
3C2		2D2		2D2A	
3C3		2D3		2D3A	
3C4		2D7		2D4A	
3C40		2D8		2D40A	
3C5		Spring Offset	Standard Type	2D5A	
3C60				2D7A	
3C7			2D9A		
3C8			2B2		2D10A
3C9		2B3		2D11A	
3C10		2B8		2D12A	
3C11					
3C12					

Two Position Spring Offset	Standard Type	Opposite Type	Two Position Spring Offset	Standard Type	Opposite Type
2B2A			2B2B		
2B3A			2B3B		
2B4A			2B4B		
2B40A			2B40B		
2B5A			2B5B		
2B60A			2B60B		
2B7A			2B7B		
2B8A			2B8B		
2B9A			2B9B		
2B10A			2B10B		
2B11A			2B11B		
2B12A			2B12B		

# SOLENOID OPERATED STACK VALVE (SECTIONAL)



## How to order

**DMW - \* - 02 T - \* - \* - \* - \***

1      2      3 4      5      6      7      8

<b>1</b>	Model							
<b>2</b>	Spool type	3C2	3C3	3C4	3C5	3C6	3C7	3C8
		3C9	3C10	3C11	3C12	3C40	2B2	2B3
<b>3</b>	Norminal valve size 1/4"							
<b>4</b>	Mounting type	T: Thread connection						
<b>5</b>	Voltage	A1: AC110V (60HZ)    A115: AC115V (50HZ)    A230: AC230V (50HZ)    A2: AC220V (60HZ) D1: DC12V    D2: DC24V						
<b>6</b>	Wiring type	None: Din type    X: Double lead						
<b>7</b>	Number of valve block	1N~7N: 1~7 blocks						
<b>8</b>	Release valve (selected mating) for inlet section	S1: DC12V    S2: DC24V    S3: RAC110V    S4: RAC220V NC: Normal closed    NO: Normal open						

## Specifications

Model	Max. Pressure (bar)	Max. Flow (lpm)	Weight (kg)
DMW-* -02T	250	70	

## Dimensions

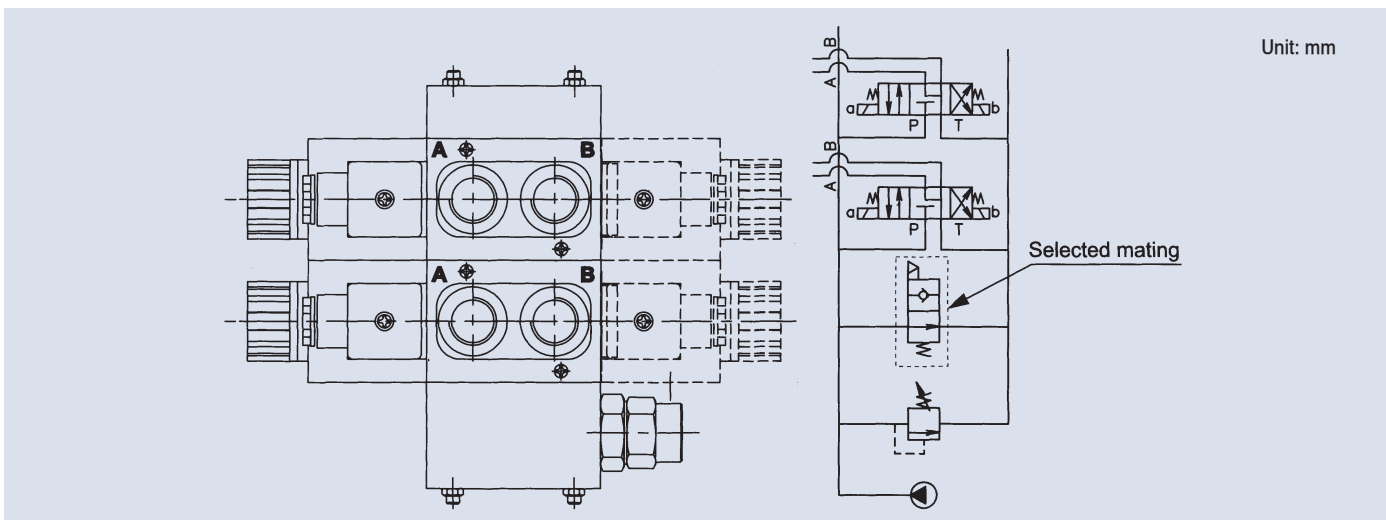

# SOLENOID OPERATED STACK VALVE (SECTIONAL)

## Dimensions

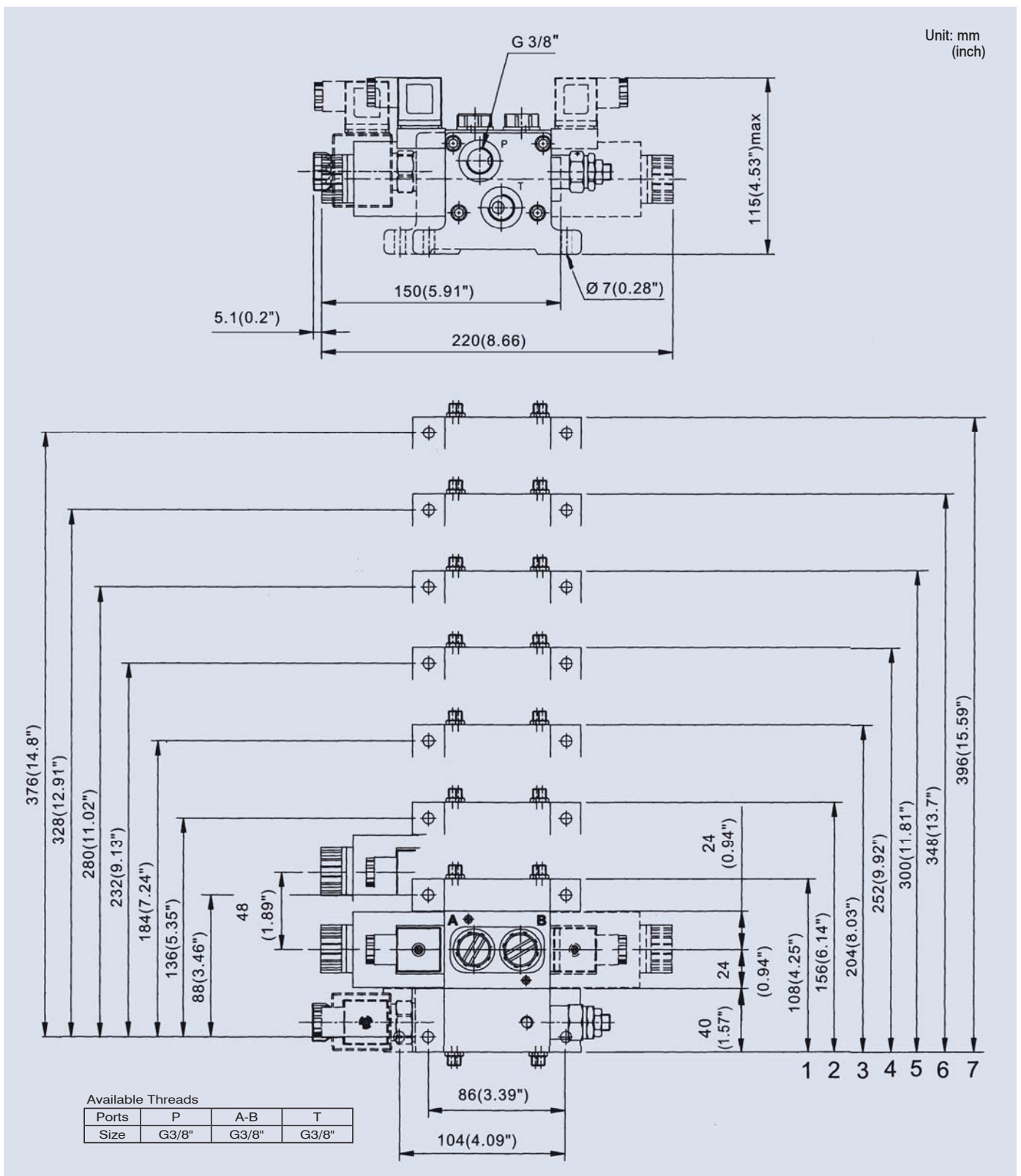

# SOLENOID MANUAL OPERATED DIRECTIONAL VALVE

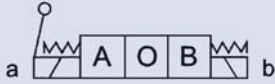

## How to order

**WED - \* - 02 G - \* - 30**

- |   |  |
|---|--|
| 1 | Model  |
| 2 | Spool type (refer to page 66)  |
| 3 | Nominal valve size 1/4" (ISO CETOP 3, NFPA D03, DIN NG 6)  |
| 4 | Mounting type G: Sub-plate mounting  |
| 5 | Voltage<br>A1: AC110V (60HZ) AC115: AC115V (60HZ) A230: AC230V (50HZ) A2: AC220V (60HZ)<br>D1: DC12V D2: DC24V R1: RF110V (50/60HZ) R2: RF220V (50/60HZ) |
| 6 | Wiring type 30: Din type  40: Amp type   |

## Specifications

Model	Max. Pressure (bar)	Max. Flow (lpm)	Weight (kg)			
			AC		DC (RF)	
			Single Sol.	Double Sol.	Single Sol.	Double Sol.
WED-**-02G	315	100	2	2.35	2.1	2.5

## Dimensions / Performance curve

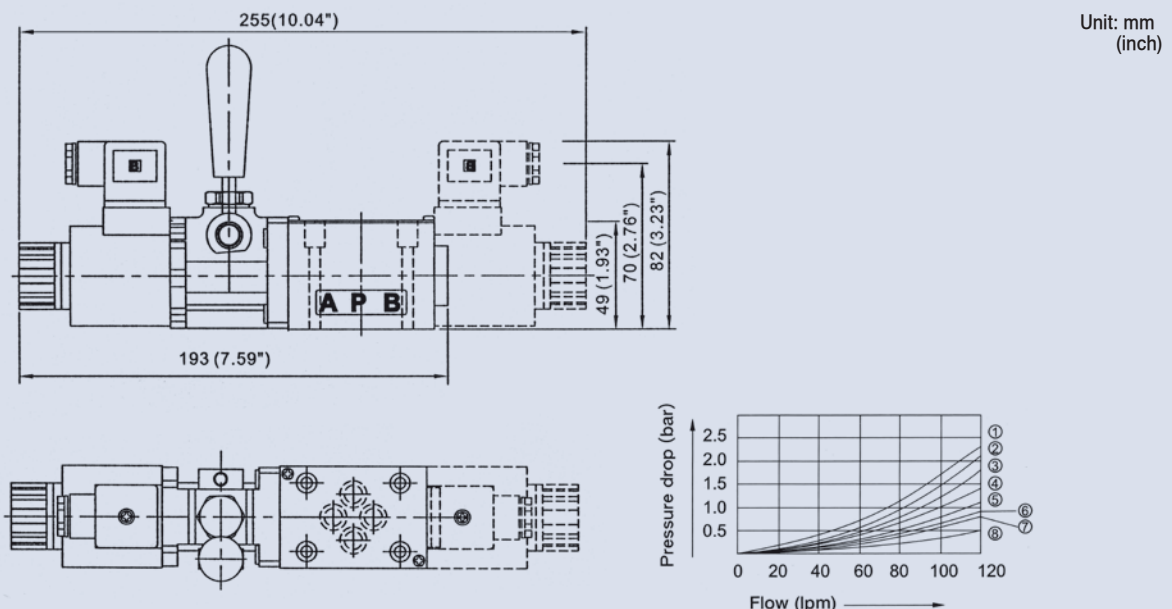

# SOLENOID OPERATED CHECK VALVE

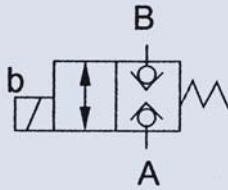

## How to order

### LVS - 02 G - A2

	1	2	3	4
1	Model			
2	Normal valve size	02: 1/4" (ISO CETOP 3, NFPA D03, DIN NG 6)	03: 3/8" (ISO CETOP 5, NFPA D05, DIN NG 10)	
3	Control type			
4	Voltage	A1: AC115V (50HZ) A2: AC230V (50HZ)	D1: DC12V D2: DC24V	

## Specifications

Model	Max. Operating Pressure (bar)	Max. Flow (lpm)	Weight (kg)
LVS-02G	250	35	1.6
LVS-03G		50	3.5

## Dimensions

### LVS-02G

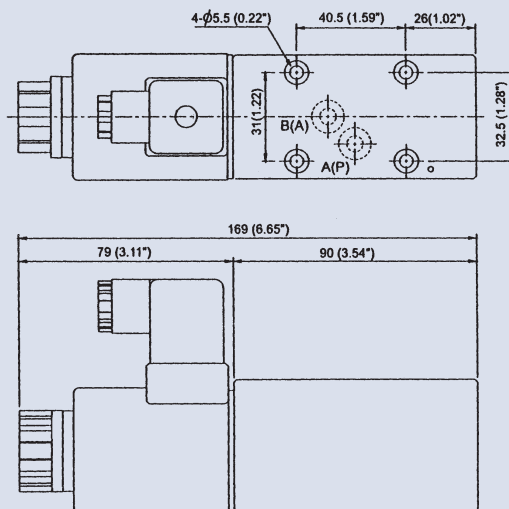

### LVS-03G

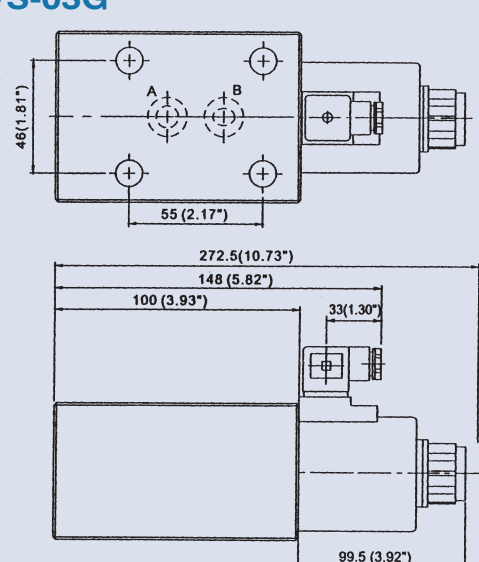

Unit: mm (inch)

# LIFT VALVE

Normal closed

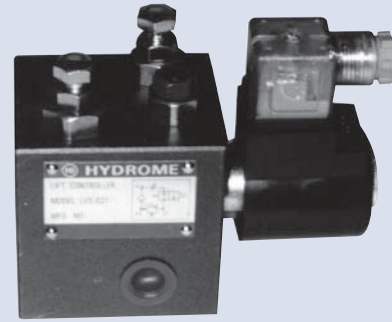
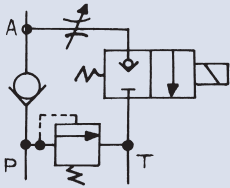

## How to order

### LVS - 03 T - NC - A22

1	2	3	4	5
1	Model LVS: Ductile iron body			
2	Valve size 03: 3/8"			
3	Mounting type T: Thread connection			
4	NC: Normal closed NO: Normal open			
5	Voltage A11: AC110V (50/60HZ) A22: AC220V (50/60HZ) D1: DC12V D2: DC24V			

## Specifications

Model	Max. Operating Pressure (bar)	Max. Flow (lpm)	Max. Frequency (cpm)	Weight (kg)
LVS-03T	250	25	120	2.8

## Dimensions / Performance curves

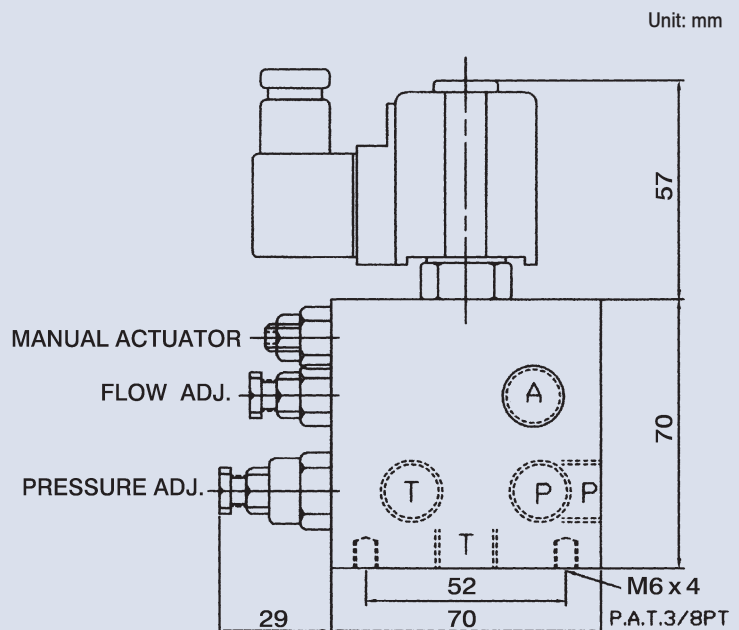
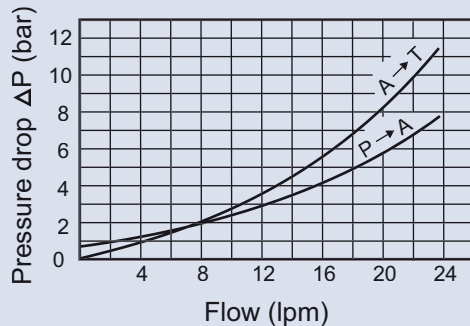

# LIFT VALVE

Normal closed

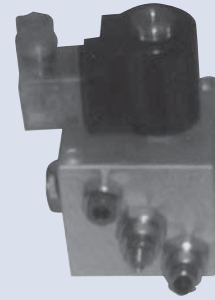
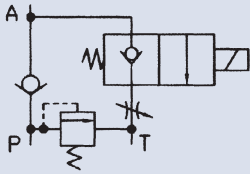

## How to order

### KVS - 03 TL - NC - A22

	1	2	3	4	5
1	Model	Aluminum alloy body			
2	Valve size	03: 3/8"	04: 1/2"		
3	Mounting type	TL: Thread connection			
4	NC: Normal closed	NO: Normal open			
5	Voltage	A11: AC110V (50/60HZ)	A22: AC220V (50/60HZ)	D1: DC12V	D2: DC24V

## Specifications

Model	Max. Operating Pressure (bar)	Max. Flow (lpm)	Rated Flow (lpm)	Weight (kg)
KVS-03TL	250	25	20	1.25
KVS-04TL		50	40	1.5

## Dimensions / Performance curves

### KVS-03TL

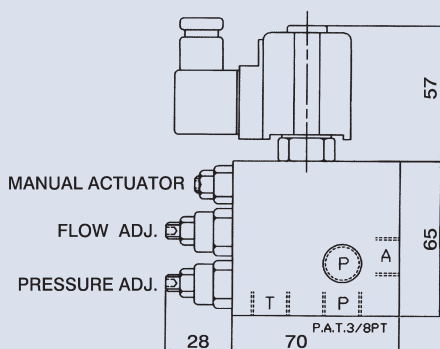
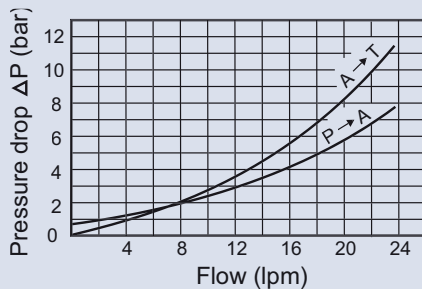

\*Holes for bolt fixing: 2-ø7 Through

### KVS-04TL

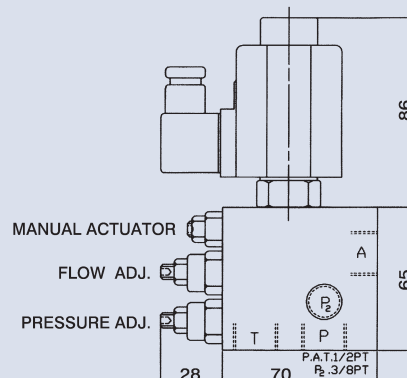
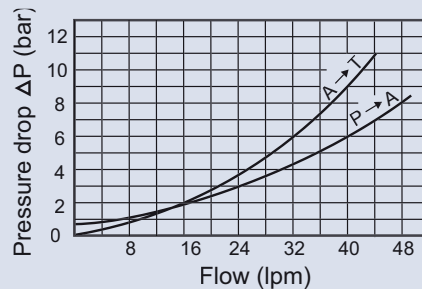

Unit: mm



# LIFT VALVE

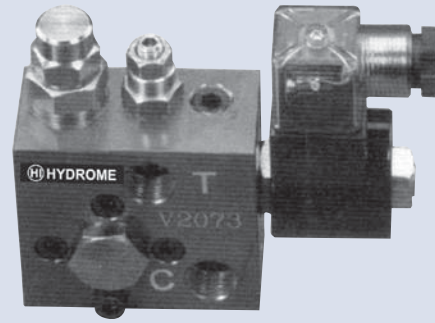
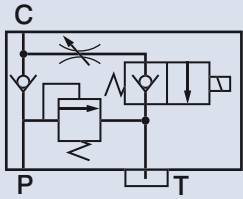

## How to order

### HV2073 - T 03 - NC - ☒ - A22

1	2	3	4	5	6
1	Model	Aluminum alloy body	Can be mounted on gear pump HGP-2A		
2	Thread connection type				
3	Port size	03: PT 3/8"			
4	NC: Normal closed	NO: Normal open			
5	None: General use	OM: With manual actuator			
6	Voltage	A11: AC110V (50/60HZ)	A22: AC220V (50/60HZ)	D1: DC12V	D2: DC24V

## Specifications

Model	Max. Operating Pressure (bar)	Max. Flow (lpm)	Rated Flow (lpm)	Weight (kg)
HV2073	250	20	15	0.93

## Dimensions

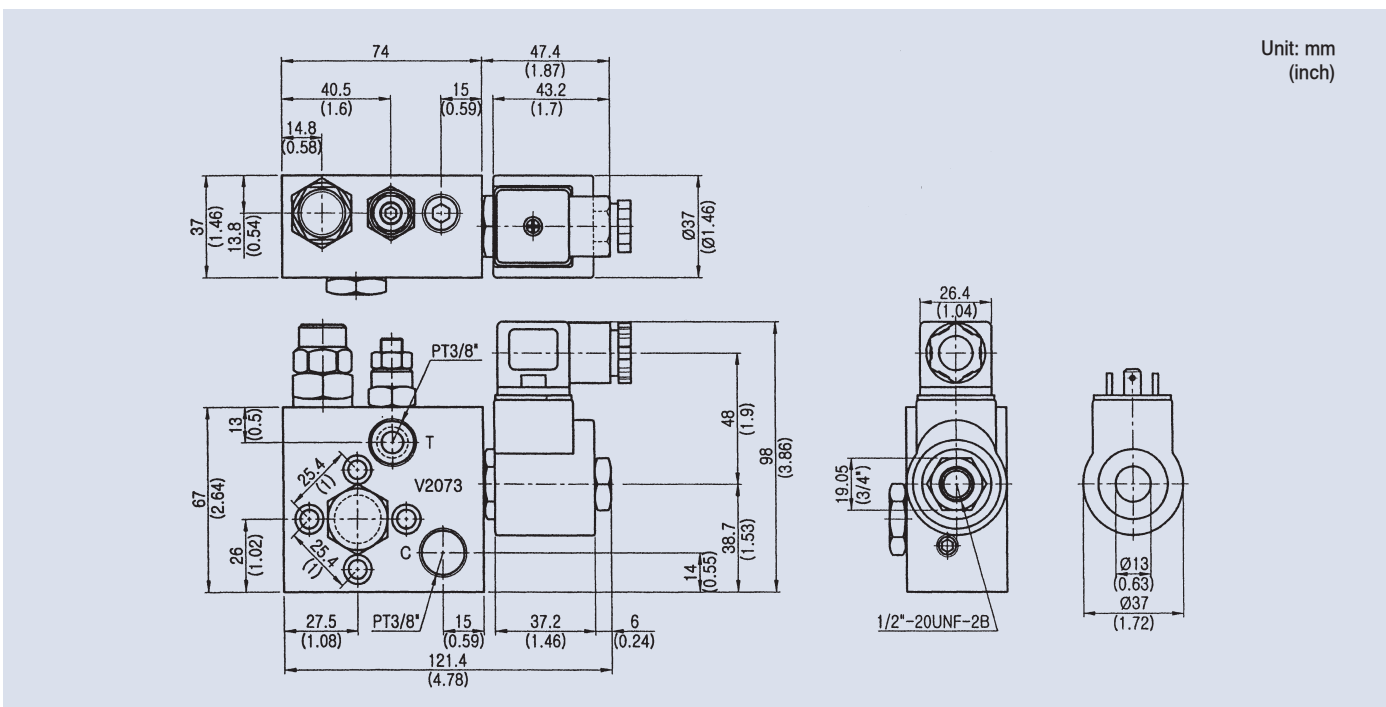

# LIFT VALVE

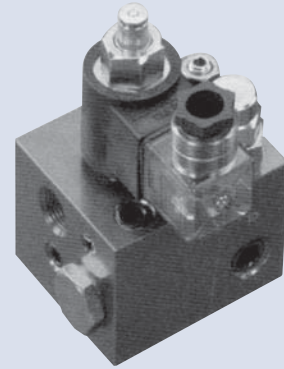
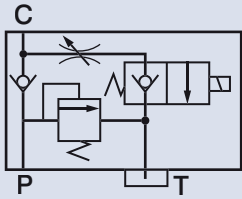

## How to order

**HV2074 - T 03 - NC - ✱ - A22**

1      2      3      4      5      6

1	Model	Aluminum alloy body
2	Thread connection type	
3	Port size	03: PT 3/8"
4	NC: Normal closed	NO: Normal open
5	None: General use	OM: With manual actuator
6	Voltage	A11: AC110V (50/60HZ)    A22: AC220V (50/60HZ)    D1: DC12V    D2: DC24V

## Specifications

Model	Max. Operating Pressure (bar)	Max. Flow (lpm)	Rated Flow (lpm)	Weight (kg)
HV2074	250	20	15	1.05

## Dimensions

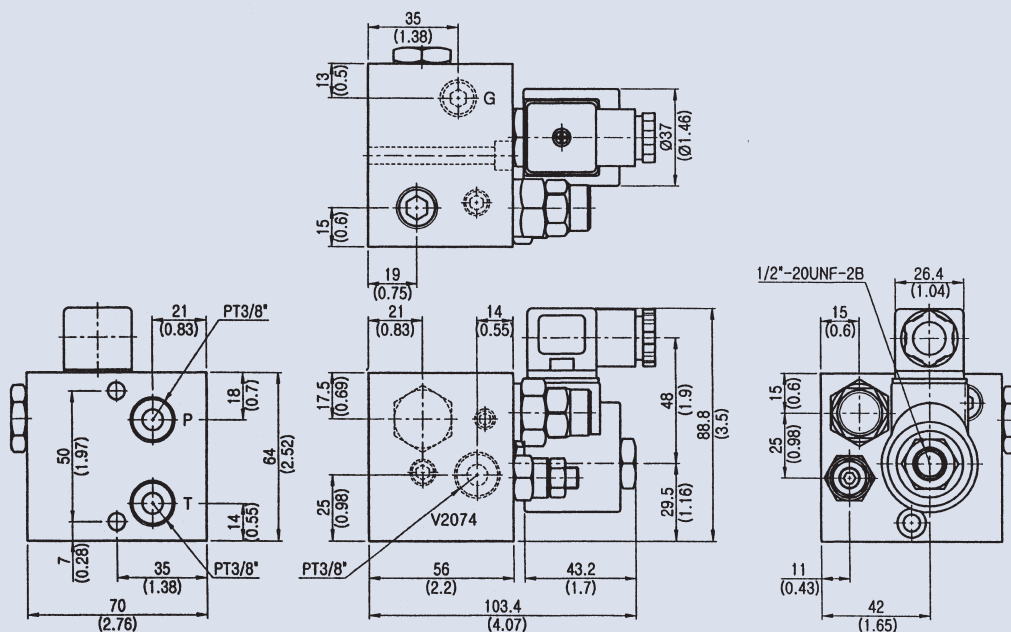

Unit: mm  
(inch)

# LIFT VALVE

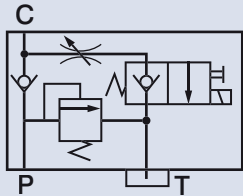

## How to order

### **HV3074 - T 04 - NC - \* - A22**

1	2	3	4	5	6
1	Model	Aluminum alloy body			
2	Thread connection type				
3	Port size	04: PT 1/2"			
4	NC: Normal closed NO: Normal open				
5	None: General use OM: With manual actuator				
6	Voltage	A11: AC110V (50/60HZ) A22: AC220V (50/60HZ) D1: DC12V D2: DC24V			

## Specifications

Model	Max. Operating Pressure (bar)	Max. Flow (lpm)	Rated Flow (lpm)	Weight (kg)
HV3074	250	50	45	1.6

## Dimensions

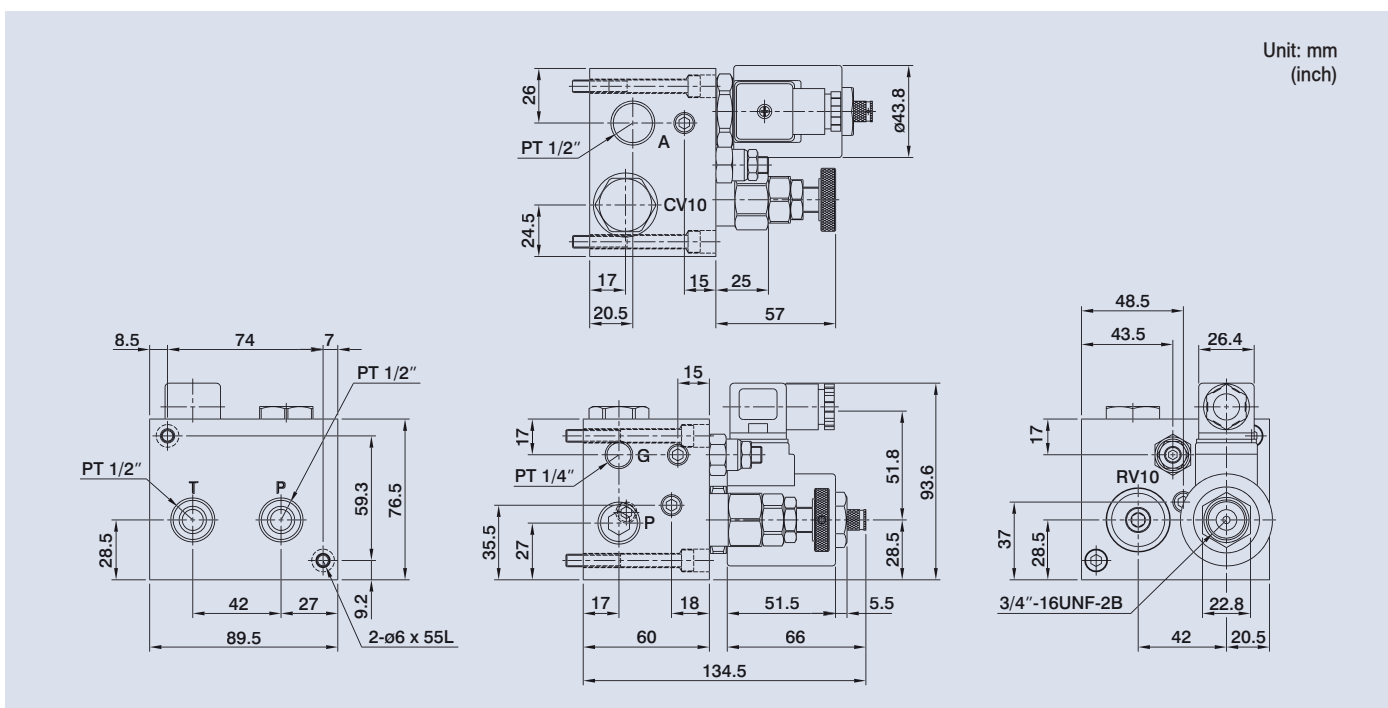

# LIFT VALVE

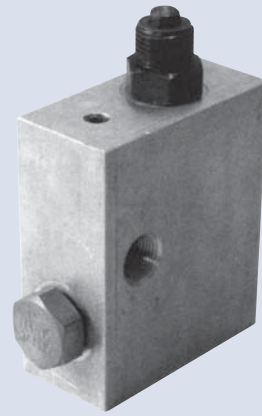
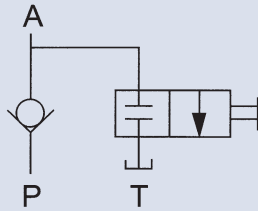

## How to order

### VLT - 03

1	2
1	Model Manual actuating
2	Port size 03: 3/8"

## Specifications

Model	Max. Operating Pressure (bar)	Max. Flow (lpm)	Rated Flow (lpm)	Weight (kg)
VLT-03	250	20	15	1

## Dimensions

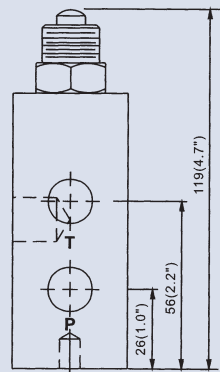
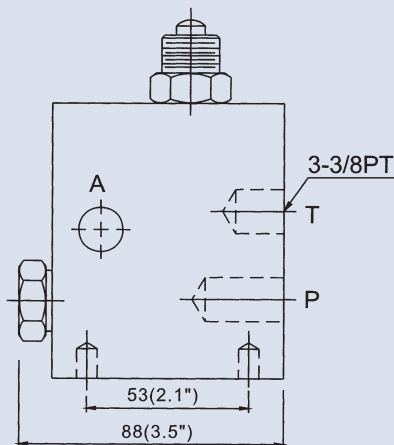
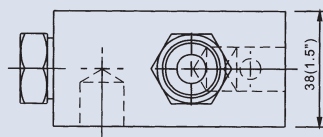

Unit: mm  
(inch)

# HOSE BURST PROTECTION VALVE

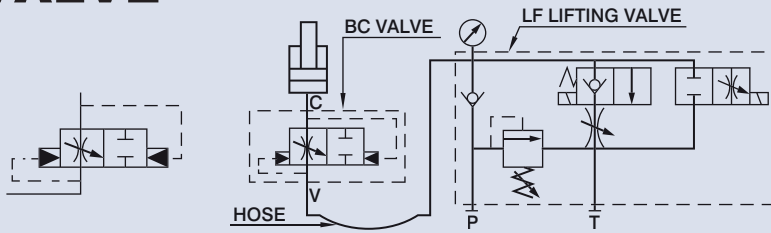

## FUNCTION:

Under normal operation conditions, this valve is normally open. When the system flow going through this valve has a sudden increase over the preset flow velocity level due to system failure, hose burst, or over-load, this valve will shut off automatically to provide safety for operators.

## FEATURES:

- The desired flow rate is adjustable and can be preset.
- Compact design provides ease for installation. If C port is mounted directly to T cylinder, the result is even better.

## Specifications

Model	A	B	C	D	E	F	G	H	I	J	Max. Operating Pressure (bar)	Max. Flow (lpm)	Weight (kg)
VF-30	38	25	13	36	15	51	25	4	25	PT3/8"	210	30	0.15
VF-80	50	33	17	46	17	63	31	4	32	PT1/2"	210	60	0.31
VF-120	63	42	21	52	20	72	30	4	44	PT3/4"	210	90	0.53
VF-160	50.8	25.4	25.4	53.5	29	82.5	25	6	50.8	PT1"	210	250	0.75

## Dimensions

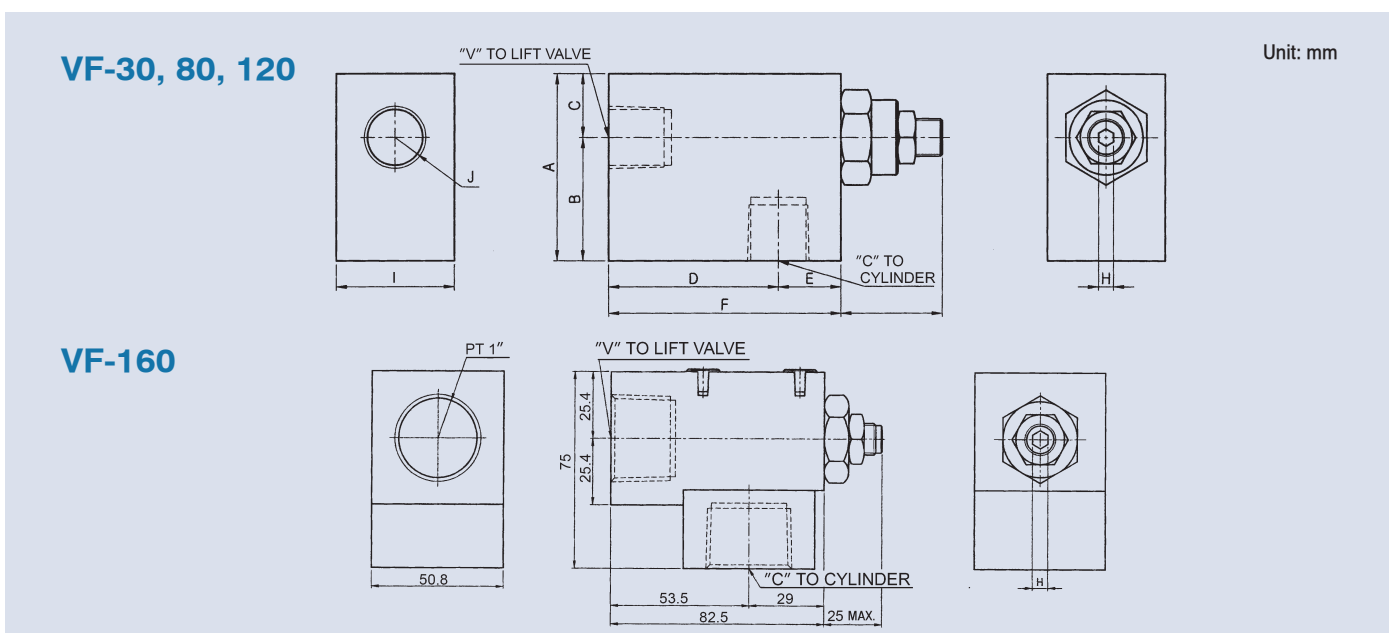

# HOSE BURST PROTECTION VALVE

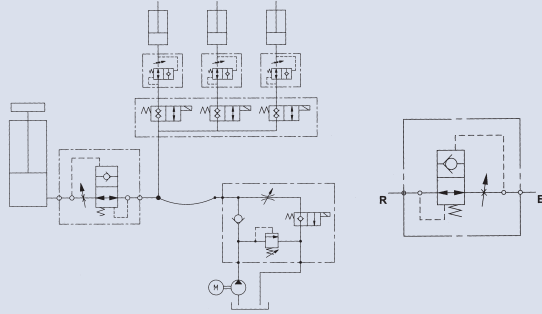

## Specifications

Model	Popt Size	Max. Pressure (bar)	Max. Flow (lpm)	Weight (kg)
VAS-02	G 1/4"	350	25	0.12
VAS-03	G 3/8"		50	0.15
VAS-04	G 1/2"		80	0.23
VAS-06	G 3/4"		150	0.36
VAS-08	G 1"		220	1.05

## Dimensions / Performance curves

Unit: mm  
(inch)

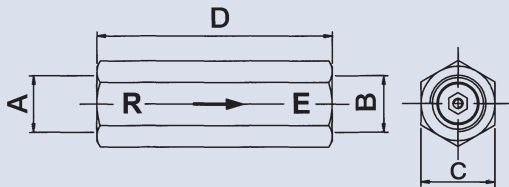

Model	A	B	C	D
VAS-02	G 1/4"	G 1/4"	19 (0.75")	66 (2.6")
VAS-03	G 3/8"	G 3/8"	22 (0.86")	70 (2.76")
VAS-04	G 1/2"	G 1/2"	27 (1.06")	80 (3.15")
VAS-06	G 3/4"	G 3/4"	32 (1.26")	100 (3.94")
VAS-08	G 1"	G 1"	46 (1.81")	115 (4.53")

### VAS-02

Pressure Drop (bar) R-E

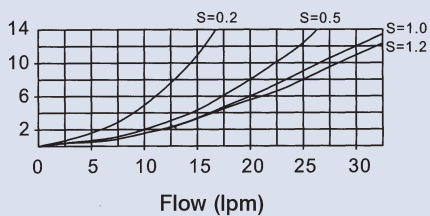

### VAS-04

Pressure Drop (bar) R-E

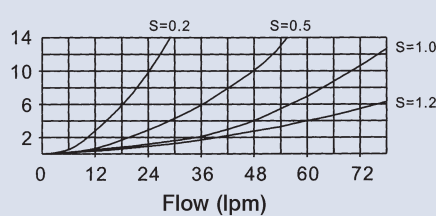

### VAS-08

Pressure Drop (bar) R-E

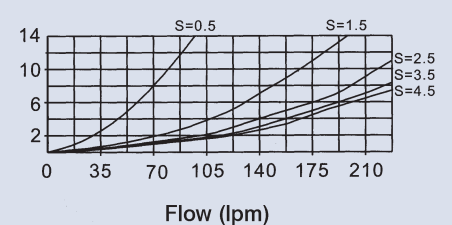

### VAS-03

Pressure Drop (bar) R-E

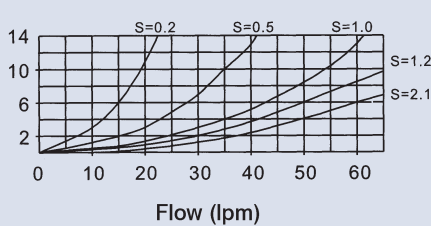

### VAS-06

Pressure Drop (bar) R-E

