

HYDRAULIC CYLINDER

How to order

HOB - 63 * **35** * **100ST** - **LB** + **Y** + * + *

1 2 3 4 5 6 7 8

1	Model	HOB : Standard type	HOD : Double rod	HOBH : HOB with magnet	HODH : HOD with magnet						
2	Bore DIA.	3 Rod DIA.									
	Bore DIA. (mm)	40	50	63	80	100	125	150	180	200	
	Rod DIA. (mm)	Standard-heavy duty (Max.)		25	30-35	35-40	40-50	50-60	60-80	80-100	100-120
	With cushion	18	25	35	40	50	60	80	100		
4	Stroke	Carbon steel tube: For bore ø40-200 stroke Max. 4 meters				Stainless steel tube: For bore ø40-100 stroke Max. 2.8 meters					
5	Mounting type	FA : Front flange	FB : Rear flange	LA : Side lugs	LB : Foot stand	TC : Center trunnion	CA : Male clevis	CB : Female clevis	CBP : CB clevis with pin		
6	Mounting accessory	Y : Adaptor	YP : Y adaptor with pin	I : Adaptor	KG : Compensating joint	PHS : Rod end	A : Adjustable nut	T : T rod end	H : H rod end		
7	Cushion	None: Without cushion PPV: With cushion									
8	Sensor switch	None: Without sensor switch ES1: 1pc of sensor switch ES2: 2 pcs of sensor switch									

Specifications

Bore Size of Cylinder (mm)	Power Fluid	Material of Cylinder tube	The range of pressure (bar)	The range of temperature (°C)	The range of speed (mm/sec)	Cushion Stroke (mm)	Piston length (PM) For Stroke 1501~2500 mm	Piston length (PM) For Stroke 2501~4000 mm
ø40	Filtered oil	Carbon steel STKM-13C/ stainless steel SUS 304	3~160	-10°~+60°	8~300	20	60	120
ø50						25	70	140
ø63						25	70	140
ø80						30	80	150
ø100						35	100	180
ø125						40	100	180
ø150						45	100	180
ø180						50	140	200
ø200						55	140	200

Parts list

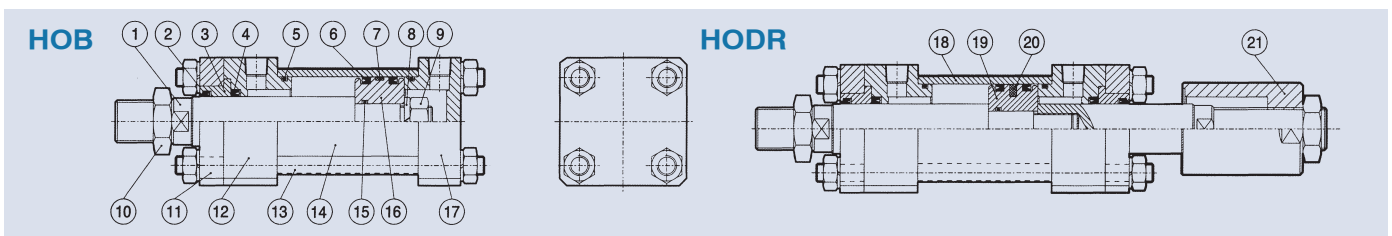

No.	Part Name	Quantity	No.	Part Name	Quantity	No.	Part Name	Quantity	No.	Part Name	Quantity
1	Piston rod	1	7	Wearing ring	1	13	Tie bolt	4	19	Piston	1
2	Dust wiper	1	8	Spring washer	1	14	Cylinder tube	1	20	Magnet ring	1
3	Rod bush	1	9	Nut	1	15	O-Ring	1	21	Adjustable nut	1
4	Rod packing	1	10	Rod nut	1	16	Piston	1			
5	O-Ring	2	11	End plate	1	17	Rear cover	1			
6	Piston packing	2	12	Rod cover	1	18	Cylinder tube	1			

HYDRAULIC CYLINDER

Dimensions

HOB HO+B (Standard Type)

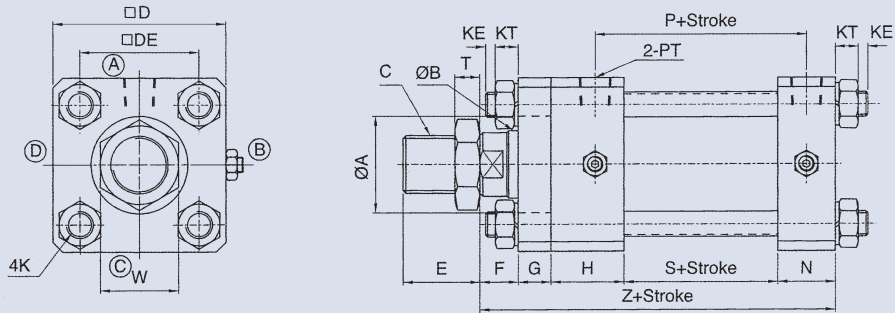

HOD HO+D (Double rod Type)

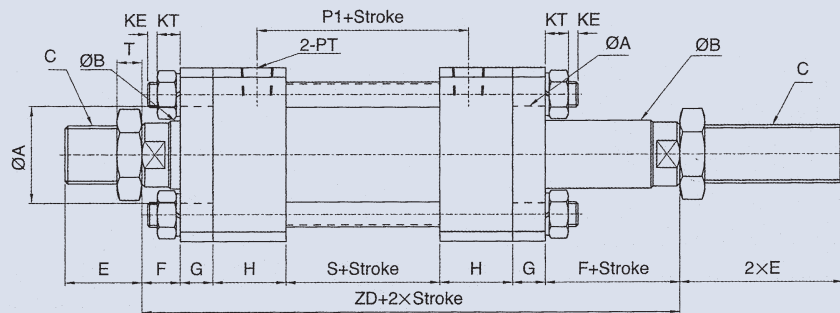

HOD HOD+AST (With adjustable nut)

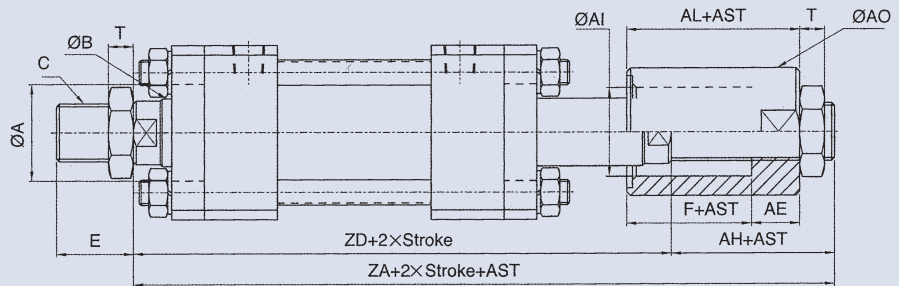

HOB-HOD Type																				Adjustable Type								
Size Bore	øA	øB	C	□D	□DE	E	F	G	H	N	P	P1	PM	PT	K	KE	KT	S	T	W	Z	ZD	ZA	AH	AE	øAI	øAO	AL
ø40	40	25	M22xP1.5	65	45	40	20	17	33	28	76	74	30	3/8	M10xP1.25	10	10.5	50	13	32	148	190	225	35	20	30	45	40
ø50	45	30	M26xP1.5	80	56	40	20	17	38	30	85	85	35	3/8	M12xP1.5	10	13	55	13	35	160	205	245	40	25	37	55	45
ø63	50	35	M30xP1.5	90	62	45	20	17	38	30	85	85	35	3/8	M14xP1.5	10	14.5	55	13	41	160	205	245	40	25	42	60	45
ø80	55	40	M30xP1.5	110	80	45	20	20	38	35	107	105	50	1/2	M16xP1.5	10	17	75	13	41	188	231	276	45	30	47	70	50
ø100	65	50	M40xP2.0	131	95	55	25	20	41	37	123.5	120	60	1/2	M18xP1.5	10	19.5	90	15	55	213	262	307	45	30	57	90	55
ø125	80	60	M50xP2.0	162	122	70	35	30	57	47	143	140	70	3/4	M22xP1.5	10	23.5	100	15	65	269	344	394	50	35	68	100	70
ø150	100	80	M70xP2.0	195	144	80	35	30	60	50	135	130	60	3/4	1"-8 UNC	5	30	90	20	90	265	340	400	60	40	90	120	75
ø180	120	100	M90xP2.0	235	175	100	35	40	65	55	172	170	70	1	1,1/4"-8 UNC	10	35	120	20	110	315	400	465	65	40	110	150	75
ø200	120	100	M90xP2.0	262	193	100	40	40	65	60	175	170	70	1	1,1/4"-8 UNC	10	35	120	20	110	325	410	475	65	40	110	150	80

- The length and size of the piston rod were not specified when being enlarged or reduced, the size will be constructed according to the dimensions table.
- When the stroke exceeds (includes) 1501 mm, see the specifications table for the length of the piston. Within 1500 mm (included) see the (PM) length of piston in the dimensions table.
- When the stroke exceeds (includes) 2000 mm, the fixed base for the tie rod must be added in the middle.
- The screw nut for piston rod over M50 is round shape.
- AST is the custom-made adjustable stroke.

HYDRAULIC CYLINDER

Dimensions

HOB HOB+FA Type

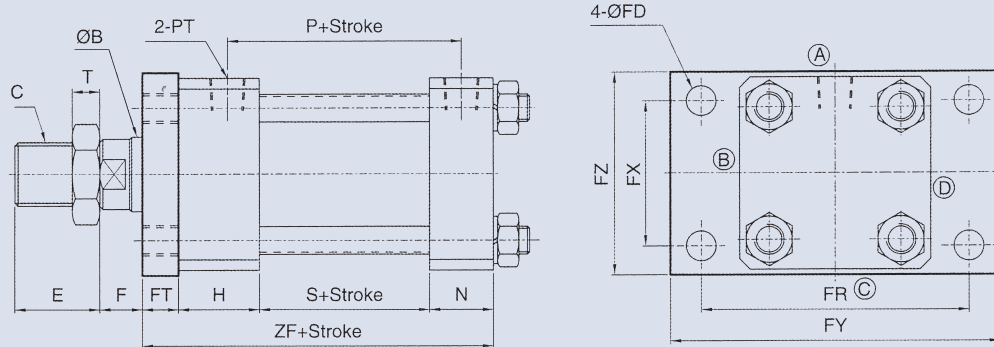

HOD HOD+FA Type

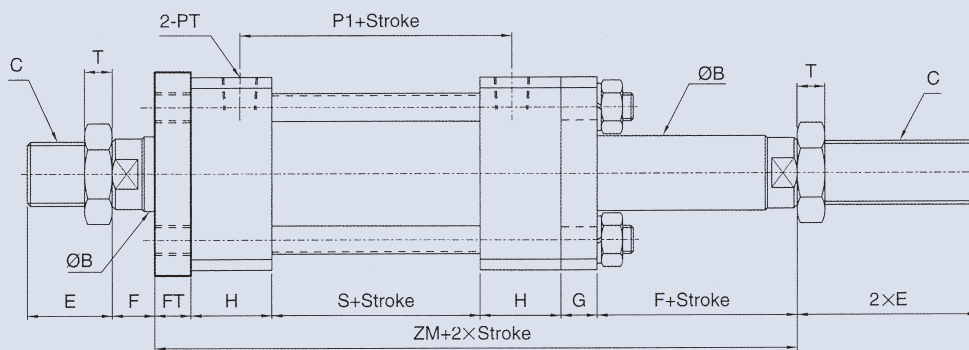

HOB-HOD Type															FA Type						
Size Bore	$\varnothing B$	C	E	F	G	H	N	P	P1	PM	PT	S	T	ZF	ZM	$\varnothing FD$	FT	FR	FX	FY	FZ
$\varnothing 40$	25	M22 x P1.5	40	20	17	33	28	76	74	30	3/8	50	13	128	170	12	17	93	50	115	75
$\varnothing 50$	30	M26 x P1.5	40	20	17	38	30	85	85	35	3/8	55	13	140	185	14	17	110	56	150	85
$\varnothing 63$	35	M30 x P1.5	45	20	17	38	30	85	85	35	3/8	55	13	140	185	14	17	126	68	155	95
$\varnothing 80$	40	M30 x P1.5	45	20	20	38	35	107	105	50	1/2	75	13	168	211	18	20	152	75	190	120
$\varnothing 100$	50	M40 x P2.0	55	25	20	41	37	123.5	120	60	1/2	90	15	188	237	20	20	180	100	220	140
$\varnothing 125$	60	M50 x P2.0	70	35	30	57	47	143	140	70	3/4	100	15	234	309	24	30	222	122	280	170
$\varnothing 150$	80	M70 x P2.0	80	35	30	60	50	135	130	60	3/4	90	20	230	305	28	30	260	155	310	206
$\varnothing 180$	100	M90 x P2.0	100	35	40	65	55	172	170	70	1	120	20	280	365	35	40	315	188	375	250
$\varnothing 200$	100	M90 x P2.0	100	40	40	65	60	175	170	70	1	120	20	285	370	35	40	355	207	425	272

- The length and size of the piston rod were not specified when being enlarged or reduced, the size will be constructed according to the dimensions table.
- When the stroke exceeds (includes) 1501 mm, see the specifications table for the length of the piston. Within 1500 mm (included) see the (PM) length of piston in the dimensions table.
- The screw nut for piston rod over M50 is round shape.

HYDRAULIC CYLINDER

Dimensions

HOB HOB+FB Type

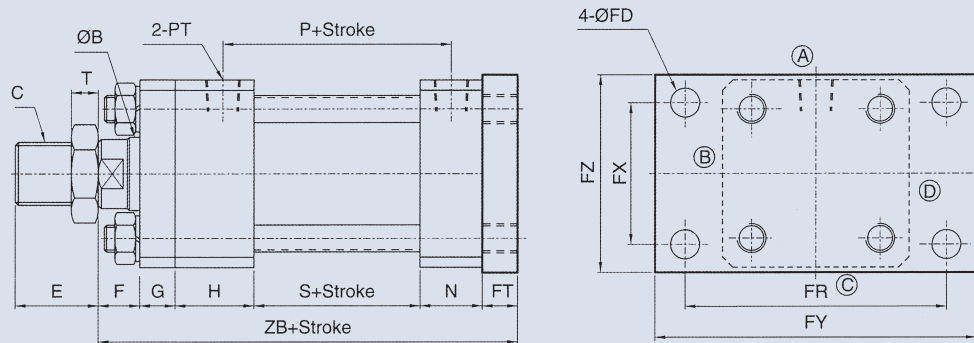

HOD HOD+FB Type

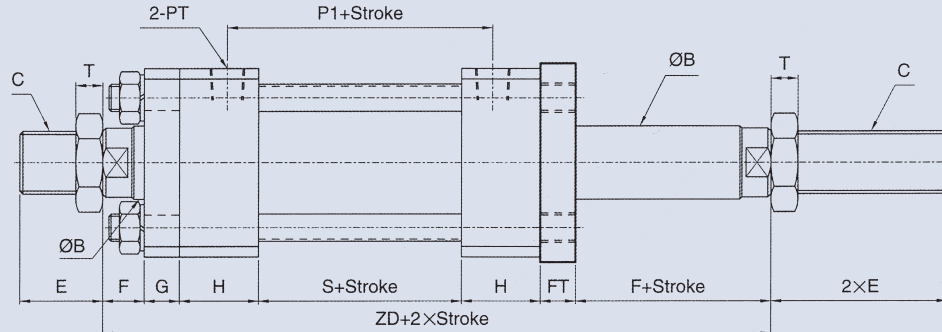

Bore	Size	HOB-HOD Type														FB Type					
		$\varnothing B$	C	E	F	G	H	N	P	P1	PM	PT	S	T	ZB	ZD	$\varnothing FD$	FT	FR	FX	FY
$\varnothing 40$	25	M22 x P1.5	40	20	17	33	28	76	74	30	3/8	50	13	165	190	12	17	93	50	115	75
$\varnothing 50$	30	M26 x P1.5	40	20	17	38	30	85	85	35	3/8	55	13	177	205	14	17	110	56	150	85
$\varnothing 63$	35	M30 x P1.5	45	20	17	38	30	85	85	35	3/8	55	13	177	205	14	17	126	68	155	95
$\varnothing 80$	40	M30 x P1.5	45	20	20	38	35	107	105	50	1/2	75	13	208	231	18	20	152	75	190	120
$\varnothing 100$	50	M40 x P2.0	55	25	20	41	37	123.5	120	60	1/2	90	15	233	262	20	20	180	100	220	140
$\varnothing 125$	60	M50 x P2.0	70	35	30	57	47	143	140	70	3/4	100	15	299	344	24	30	222	122	280	170
$\varnothing 150$	80	M70 x P2.0	80	35	30	60	50	135	130	60	3/4	90	20	295	340	28	30	260	155	310	206
$\varnothing 180$	100	M90 x P2.0	100	35	40	65	55	172	170	70	1	120	20	355	400	35	40	315	188	375	250
$\varnothing 200$	100	M90 x P2.0	100	40	40	65	60	175	170	70	1	120	20	365	410	35	40	355	207	425	272

- The length and size of the piston rod were not specified when being enlarged or reduced, the size will be constructed according to the dimensions table.
- When the stroke exceeds (includes) 1501 mm, see the specifications table for the length of the piston. Within 1500 mm (included) see the (PM) length of piston in the dimensions table.
- The screw nut for piston rod over M50 is round shape.

HYDRAULIC CYLINDER

Dimensions

HOB HOB+LA Type

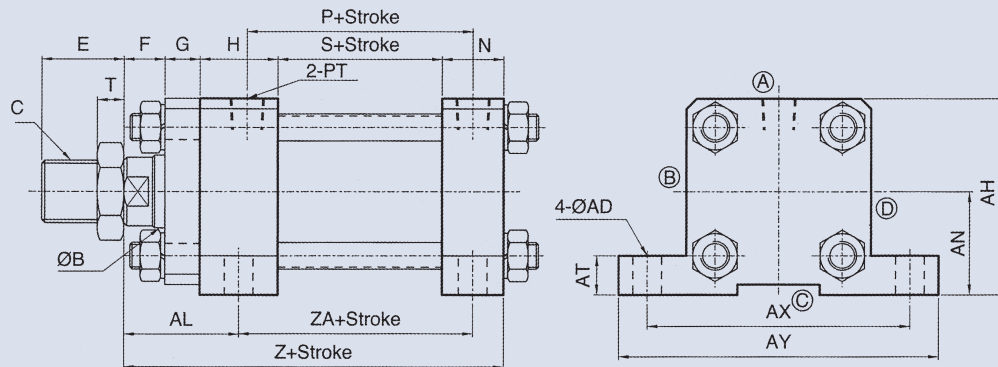

HOD HOD+LA Type

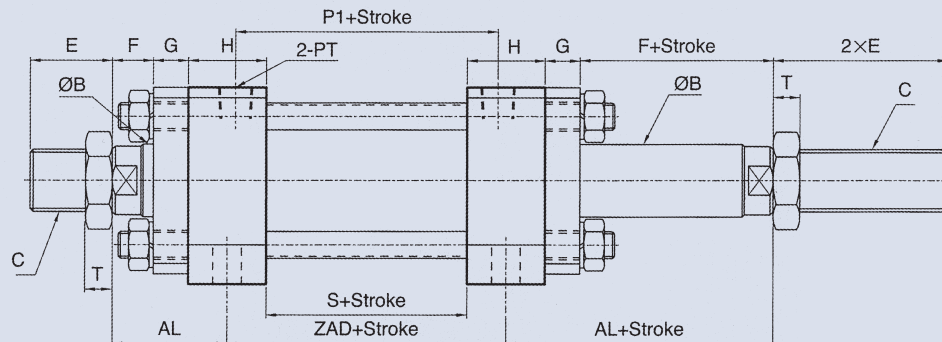

Size Bore	HOB-HOD Type																			LA Type			
	ØB	C	E	F	G	H	N	AH	AL	AN	P	P1	PM	PT	S	T	ZA	ZAD	Z	ØAD	AT	AX	AY
ø40	25	M22 x P1.5	40	20	17	33	28	69.5	53.5	37	76	74	30	3/8	50	13	80.5	83	148	12	14	90	112
ø50	30	M26 x P1.5	40	20	17	38	30	85	56	45	85	85	35	3/8	55	13	89	93	160	14	17	115	140
ø63	35	M30 x P1.5	45	20	17	38	30	95	56	50	85	85	35	3/8	55	13	89	93	160	14	19	128	156
ø80	40	M30 x P1.5	45	20	20	38	35	115	59	60	107	105	50	1/2	75	13	111.5	113	188	18	25	152	184
ø100	50	M40 x P2.0	55	25	20	41	37	135.5	65.5	70	123.5	120	60	1/2	90	15	129	131	213	21	27	178	210
ø125	60	M50 x P2.0	70	35	30	57	47	171	93.5	90	143	140	70	3/4	100	15	152	157	269	24	30	230	280
ø150	80	M70 x P2.0	80	35	30	60	50	208	95	113	135	130	60	3/4	90	20	145	150	265	28	35	270	325
ø180	100	M90 x P2.0	100	35	40	65	55	260.5	107.5	143	172	170	70	1	120	20	180	185	315	35	45	330	395
ø200	100	M90 x P2.0	100	40	40	65	60	292	112.5	161	175	170	70	1	120	20	182.5	185	325	35	50	360	430

- The length and size of the piston rod were not specified when being enlarged or reduced, the size will be constructed according to the dimensions table.
- When the stroke exceeds (includes) 1501 mm, see the specifications table for the length of the piston. Within 1500 mm (included) see the (PM) length of piston in the dimensions table.
- When the stroke exceeds (includes) 2000 mm, the fixed base for the tie rod must be added in the middle.
- The screw nut for piston rod over M50 is round shape.

HYDRAULIC CYLINDER

Dimensions

HOB HOB+LB Type

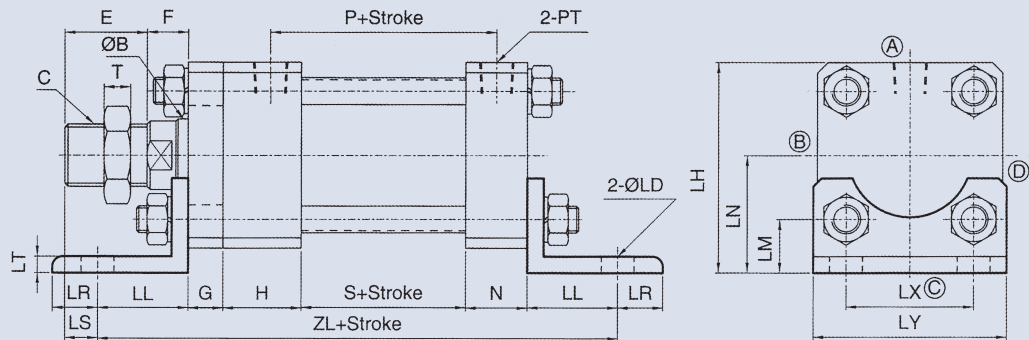

HOD HOD+LB Type

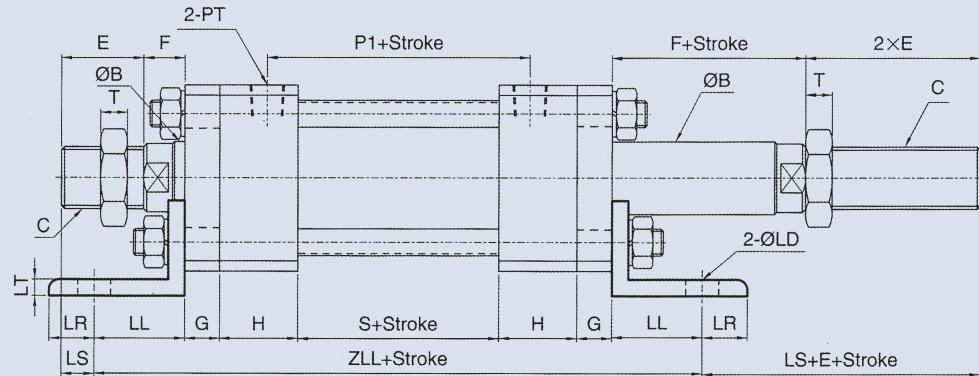

HOB-HOD Type																	LB Type								
Size Bore	ØB	C	E	F	G	H	N	LH	LN	LS	P	P1	PM	PT	S	T	ZL	ZLL	ØLD	LL	LM	LR	LT	LX	LY
ø40	25	M22 x P1.5	40	20	17	33	28	78.5	46	22.5	76	74	30	3/8	50	13	203	225	11	37.5	23.5	12.5	6	45	68
ø50	30	M26 x P1.5	40	20	17	38	30	94	54	18	85	85	35	3/8	55	13	224	249	14	42	26	22	8	56	85
ø63	35	M30 x P1.5	45	20	17	38	30	102	57	21	85	85	35	3/8	55	13	228	253	16	44	26	22	8	62	95
ø80	40	M30 x P1.5	45	20	20	38	35	131	76	2	107	105	50	1/2	75	13	294	317	18	63	36	27	13	80	120
ø100	50	M40 x P2.0	55	25	20	41	37	158.5	93	14	123.5	120	60	1/2	90	15	320	344	20	66	45.5	24	15	100	140
ø125	60	M50 x P2.0	70	35	30	57	47	195	114	25	143	140	70	3/4	100	15	394	434	24	80	53	30	15	122	169
ø150	80	M70 x P2.0	80	35	30	60	50	220	125	35	135	130	60	3/4	90	20	390	430	28	80	53	30	20	144	200
ø180	100	M90 x P2.0	100	35	40	65	55	267.5	150	45	172	170	70	1	120	20	460	510	35	90	62.5	40	20	175	240
ø200	100	M90 x P2.0	100	40	40	65	60	301	170	45	175	170	70	1	120	20	475	520	35	95	73.5	40	25	193	265

- The length and size of the piston rod were not specified when being enlarged or reduced, the size will be constructed according to the dimensions table.
- When the stroke exceeds (includes) 1501 mm, see the specifications table for the length of the piston. Within 1500 mm (included) see the (PM) length of piston in the dimensions table.
- When the stroke exceeds (includes) 2000 mm, the fixed base for the tie rod must be added in the middle.
- The screw nut for piston rod over M50 is round shape.

HYDRAULIC CYLINDER

Dimensions

HOB HOB+TA Type

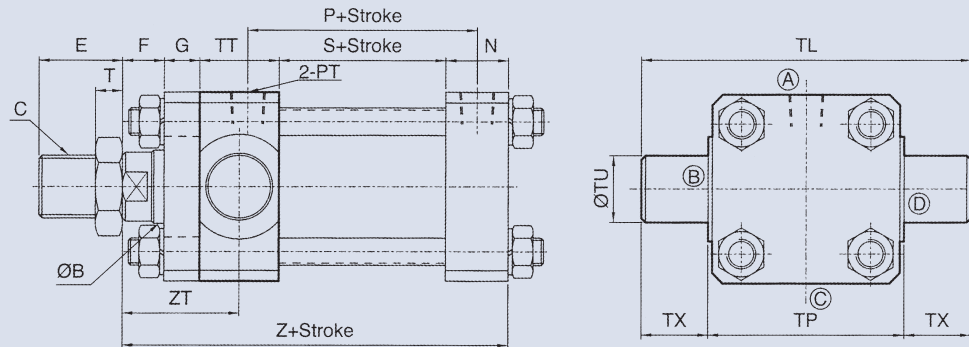

HOD HOD+TA Type

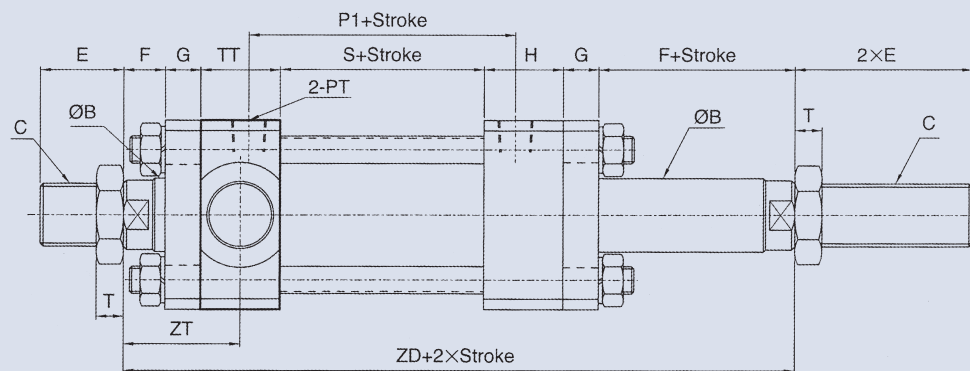

HOB-HOD Type																	TA Type				
Size Bore	øB	C	E	F	G	H	N	P	P1	PM	PT	S	T	Z	ZD	ZT	øTU	TL	TP	TT	TX
ø40	25	M22 x P1.5	40	20	17	33	28	76	74	30	3/8	50	13	148	190	53.5	20	109	69	33	20
ø50	30	M26 x P1.5	40	20	17	38	30	85	85	35	3/8	55	13	160	205	56	25	134	84	38	25
ø63	35	M30 x P1.5	45	20	17	38	30	85	85	35	3/8	55	13	160	205	56	32	154	94	38	30
ø80	40	M30 x P1.5	45	20	20	38	35	107	105	50	1/2	75	13	188	231	59	32	174	114	38	30
ø100	50	M40 x P2.0	55	25	20	41	37	123.5	120	60	1/2	90	15	213	262	65.5	35	205	135	41	35
ø125	60	M50 x P2.0	70	35	30	57	47	143	140	70	3/4	100	15	269	344	93.5	45	258	168	57	45
ø150	80	M70 x P2.0	80	35	30	60	50	135	130	60	3/4	90	20	265	340	95	50	300	200	60	50

- The length and size of the piston rod were not specified when being enlarged or reduced, the size will be constructed according to the dimensions table.
- When the stroke exceeds (includes) 1501 mm, see the specifications table for the length of the piston. Within 1500 mm (included) see the (PM) length of piston in the dimensions table.
- When the stroke exceeds (includes) 2000 mm, the fixed base for the tie rod must be added in the middle.
- The screw nut for piston rod over M50 is round shape.

HYDRAULIC CYLINDER

Dimensions

HOB HOB+TC Type

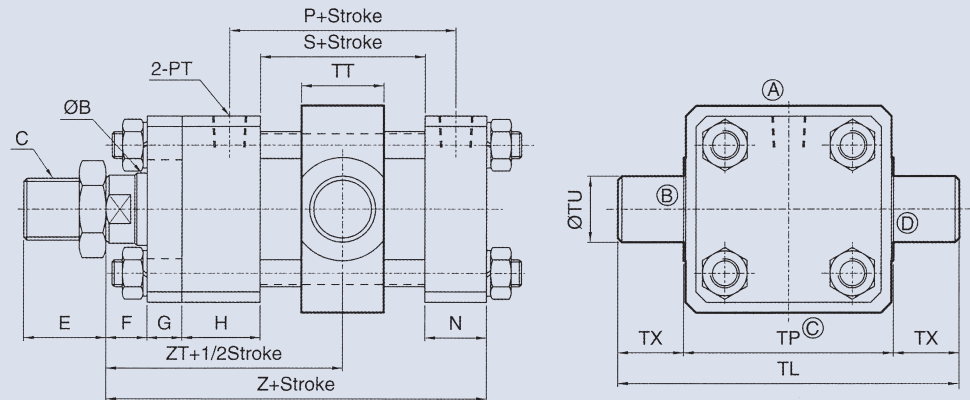

HOD HOD+TC Type

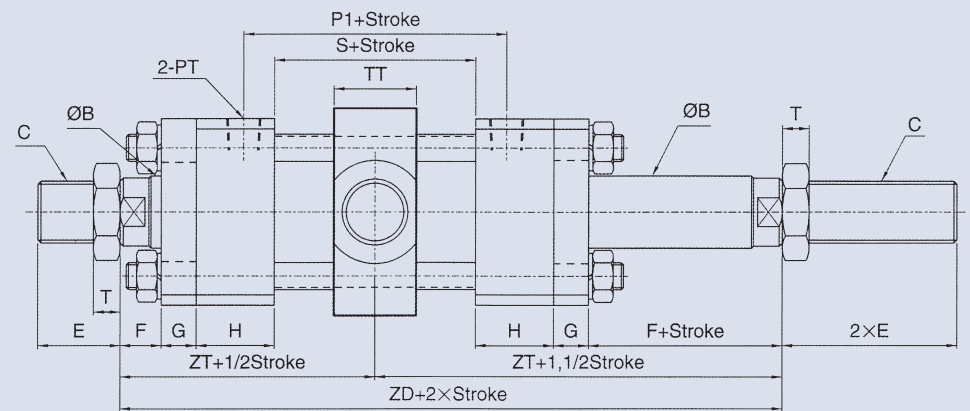

HOB-HOD Type																	TC Type				
Size	ØB	C	E	F	G	H	N	P	P1	PM	PT	S	T	Z	ZD	ZT	ØTU	TL	TP	TT	TX
Ø40	25	M22 x P1.5	40	20	17	33	28	76	74	30	3/8	50	13	148	190	95	20	115	75	28	20
Ø50	30	M26 x P1.5	40	20	17	38	30	85	85	35	3/8	55	13	160	205	102.5	25	140	90	33	25
Ø63	35	M30 x P1.5	45	20	17	38	30	85	85	35	3/8	55	13	160	205	102.5	32	166	102	40	32
Ø80	40	M30 x P1.5	45	20	20	38	35	107	105	50	1/2	75	13	188	231	115.5	32	184	120	43	32
Ø100	50	M40 x P2.0	55	25	20	41	37	123.5	120	60	1/2	90	15	213	262	131	40	220	140	53	40
Ø125	60	M50 x P2.0	70	35	30	57	47	143	140	70	3/4	100	15	269	344	172	50	275	175	58	50
Ø150	80	M70 x P2.0	80	35	30	60	50	135	130	60	3/4	90	20	265	340	170	60	326	206	73	60
Ø180	100	M90 x P2.0	100	35	40	65	55	172	170	70	1	120	20	315	400	200	80	403	243	98	80
Ø200	100	M90 x P2.0	100	40	40	65	60	175	170	70	1	120	20	325	410	205	90	452	272	108	90

- The length and size of the piston rod were not specified when being enlarged or reduced, the size will be constructed according to the dimensions table.
- When the stroke exceeds (includes) 1501 mm, see the specifications table for the length of the piston. Within 1500 mm (included) see the (PM) length of piston in the dimensions table.
- The screw nut for piston rod over M50 is round shape.

HYDRAULIC CYLINDER

Dimensions

HOB HOB+CA Type

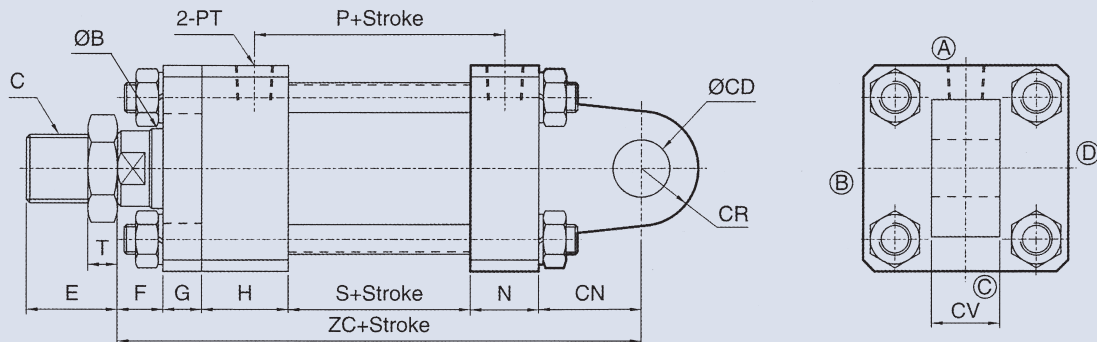

HOB HOB+CB Type

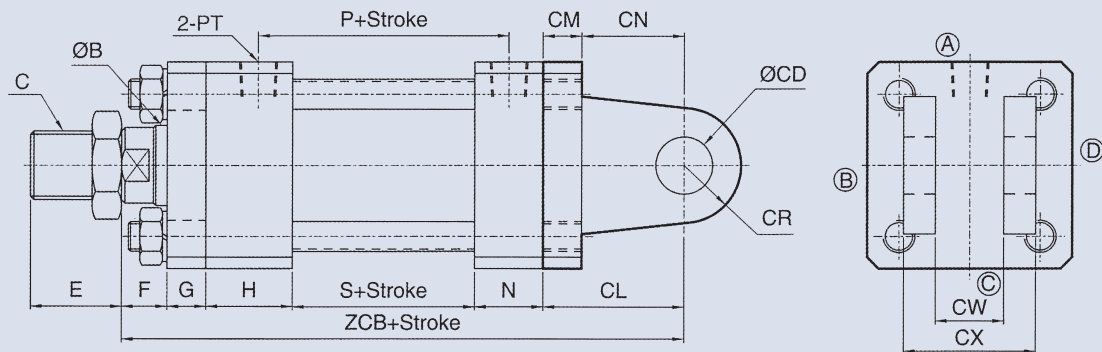

Size Bore	HOB Type													CA-CB Type								
	$\varnothing B$	C	E	F	G	H	N	P	PM	PT	S	T	ZC	ZCB	$\varnothing CD$	CL	CM	CN	CR	CV	CW	CX
$\varnothing 40$	25	M22 x P1.5	40	20	17	33	28	76	30	3/8	50	13	173	190	16	42	17	25	15	22	23	47
$\varnothing 50$	30	M26 x P1.5	40	20	17	38	30	85	35	3/8	55	13	195	212	20	52	17	35	20	22	23	47
$\varnothing 63$	35	M30 x P1.5	45	20	17	38	30	85	35	3/8	55	13	205	222	25	62	17	45	25	30	31	59
$\varnothing 80$	40	M30 x P1.5	45	20	20	38	35	107	50	1/2	75	13	238	258	30	70	20	50	30	35	36	76
$\varnothing 100$	50	M40 x P2.0	55	25	20	41	37	123.5	60	1/2	90	15	273	293	35	80	20	60	35	40	41	81
$\varnothing 125$	60	M50 x P2.0	70	35	30	57	47	143	70	3/4	100	15	339	369	50	100	30	70	50	55	56	106
$\varnothing 150$	80	M70 x P2.0	80	35	30	60	50	135	60	3/4	90	20	345	375	60	110	30	80	60	60	61	121
$\varnothing 180$	100	M90 x P2.0	100	35	40	65	55	172	70	1	120	20	415	455	80	140	40	100	80	80	81	161
$\varnothing 200$	100	M90 x P2.0	100	40	40	65	60	175	70	1	120	20	435	475	90	150	40	110	90	90	91	171

- The length and size of the piston rod were not specified when being enlarged or reduced, the size will be constructed according to the dimensions table.
- When the stroke exceeds (includes) 1501 mm, see the specifications table for the length of the piston. Within 1500 mm (included) see the (PM) length of piston in the dimensions table.
- When the stroke exceeds (includes) 2000 mm, the fixed base for the tie rod must be added in the middle.
- The screw nut for piston rod over M50 is round shape.

HYDRAULIC CYLINDER

How to order

CROC - 63* 35* 100ST - LB + Y

1 2 3 4 5 6

1	Model					
	CROB : LB type	CROC : CA type	CROA : FLAT type			
2	Bore DIA.	3 Rod DIA.				
	Bore DIA. (mm)	50	63	80	100	125
	Rod DIA. (mm) Standard-heavy duty (Max.)	30	35-45	40-55	50-70	60-80
4	Stroke					
5	Mounting type					
	FA : Front flange	FB : Rear flange	TC : Center trunnion			
6	Mounting accessory					
	Y : Adaptor	YP : Y adaptor with pin	I : Adaptor	H : H rod end		
	KG : Compensating joint	PHS : Rod end	T : T rod end			

Specifications

Bore Size of Cylinder (mm)	Power Fluid	Material of Cylinder tube	The range of pressure (bar)	The range of temperature (°C)	The range of speed (mm/sec)	Piston length (PM) For Stroke 1500~3500 mm	Piston length (PM) For Stroke 3501~6000 mm
ø50	Filtered oil	Carbon steel STKM-13C	3~160	-10°~+60°	8~300	90	120
ø63						100	150
ø80						100	150
ø100						120	180
ø125						140	200

Parts list

CROC

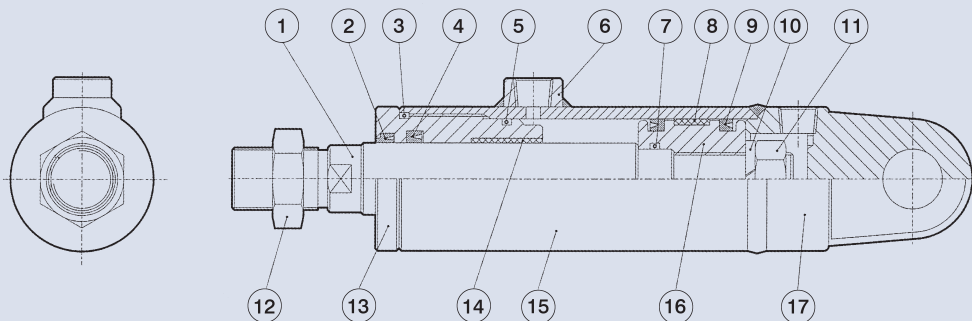

No.	Part Name	Quantity	No.	Part Name	Quantity	No.	Part Name	Quantity	No.	Part Name	Quantity
1	Piston rod	1	6	PT connectors	1	11	Nut	1	16	Piston	1
2	Dust wiper	1	7	O-Ring	1	12	Rod nut	1	17	Rear cover	1
3	O-Ring	1	8	Wearing ring	1	13	Rod cover	1			
4	Rod packing	1	9	Piston packing	2	14	Drymet bush	1			
5	O-Ring	1	10	Spring washer	1	15	Cylinder tube	1			

HYDRAULIC CYLINDER

Dimensions

CROC CRO+CA Type

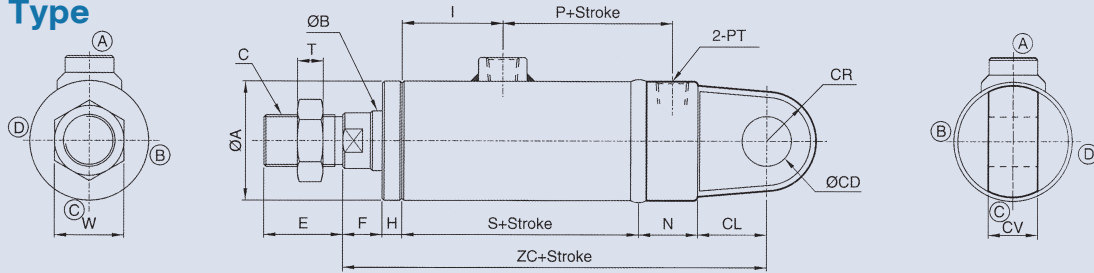

Bore	Size	CRO Type														CA Type			
		$\varnothing A$	$\varnothing B$	C	E	F	H	I	N	P	PM	PT	S	W	T	ZC	$\varnothing CD$	CL	CV
$\varnothing 50$	60	30	M26 x P1.5	40	20	10	56	30	71	45	3/8	110	35	13	205	25	35	25	25
$\varnothing 63$	73	35	M30 x P1.5	45	25	10	56	35	79	50	3/8	115	41	13	230	30	45	30	30
$\varnothing 80$	95	40	M30 x P1.5	50	25	15	64	40	83	50	3/8	125	41	13	255	30	50	35	30
$\varnothing 100$	114	50	M40 x P2.0	55	25	20	78	40	94	60	1/2	150	55	15	295	35	60	40	35
$\varnothing 125$	140	60	M50 x P2.0	70	35	20	78	50	109	70	1/2	160	65	15	335	50	70	55	50

1. The length and size of the piston rod were not specified when being enlarged or reduced, the size will be constructed according to the dimensions table.
2. When the stroke exceeds (includes) 1500 mm, see the specifications table for the length of the piston. Within 1499 mm (included) see the (PM) length of piston in the dimensions table.
3. The position of $\varnothing CD$ and $\varnothing PT$ on CA clevis showing on the drawing is for normal type and on the same direction is for optional type.

CROCB CRO+CB Type

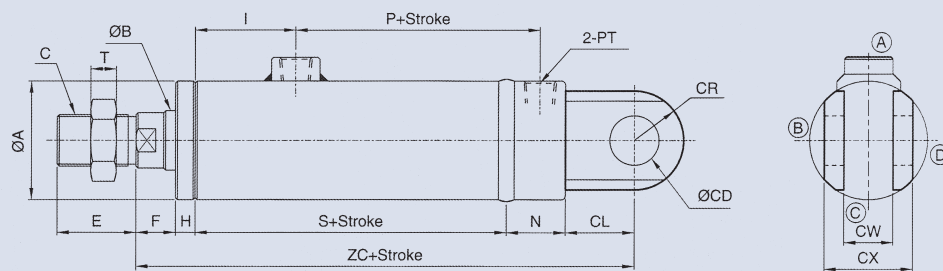

Bore	Size	CRO Type														CB Type				
		$\varnothing A$	$\varnothing B$	C	E	F	H	I	N	P	PM	PT	S	T	ZC	$\varnothing CD$	CL	CR	CW	CX
$\varnothing 50$	60	30	M26 x P1.5	40	20	10	56	30	71	45	3/8	110	13	205	25	35	25	26	46	
$\varnothing 63$	73	35	M30 x P1.5	45	25	10	56	35	79	50	3/8	115	13	230	30	45	30	31	56	
$\varnothing 80$	95	40	M30 x P1.5	50	25	15	64	40	83	50	3/8	125	13	255	30	50	30	36	66	
$\varnothing 100$	114	50	M40 x P2.0	55	25	20	78	40	94	60	1/2	150	15	295	35	60	35	41	81	
$\varnothing 125$	140	60	M50 x P2.0	70	35	20	78	50	109	70	1/2	160	15	335	50	70	50	56	106	

1. The length and size of the piston rod were not specified when being enlarged or reduced, the size will be constructed according to the dimensions table.
2. When the stroke exceeds (includes) 1500 mm, see the specifications table for the length of the piston. Within 1499 mm (included) see the (PM) length of piston in the dimensions table.
3. The position of $\varnothing CD$ and $\varnothing PT$ on CB clevis showing on the drawing is for normal type and on the same direction is for optional type.

HYDRAULIC CYLINDER

Dimensions

CROA CROA+FA Type

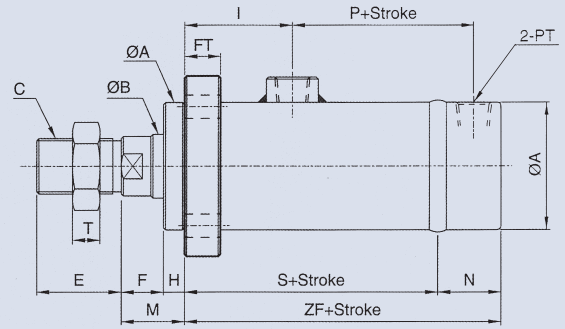
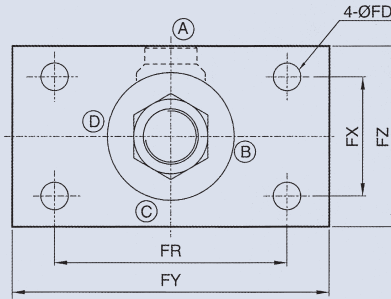

Bore	Size	CROA Type														FA Type					
		ØA	ØB	C	E	F	H	I	M	N	P	PM	PT	S	T	ZF	ØFD	FT	FR	FX	FY
Ø50	60	30	M26 x P1.5	40	20	10	56	30	30	71	45	3/8	110	13	140	14	17	110	56	150	85
Ø63	73	35	M30 x P1.5	45	25	10	56	35	35	79	50	3/8	115	13	150	14	17	126	68	155	95
Ø80	95	40	M30 x P1.5	50	25	15	64	40	40	83	50	3/8	125	13	165	18	20	152	75	190	120
Ø100	114	50	M40 x P2.0	55	25	20	78	45	40	94	60	1/2	150	15	190	20	20	180	100	220	140
Ø125	140	60	M50 x P2.0	70	35	20	78	55	50	109	70	1/2	160	15	210	24	30	222	122	280	170

1. The length and size of the piston rod were not specified when being enlarged or reduced, the size will be constructed according to the dimensions table.
2. When the stroke exceeds (includes) 1500 mm, see the specifications table for the length of the piston. Within 1499 mm (included) see the (PM) length of piston in the dimensions table.

CROB CROB+FB Type

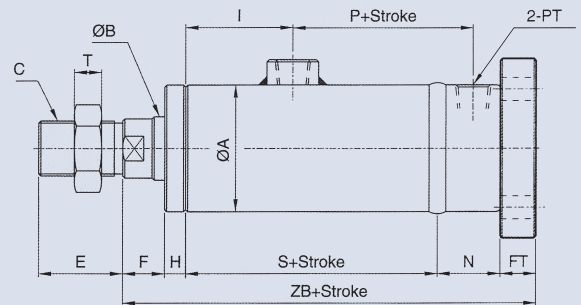
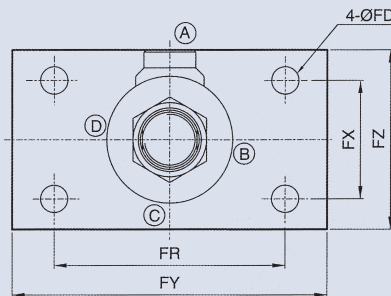

Bore	Size	CRO Type														FB Type				
		ØA	ØB	C	E	F	H	I	N	P	PM	PT	S	T	ZB	ØFD	FT	FR	FX	FY
Ø50	60	30	M26 x P1.5	40	20	10	56	30	71	45	3/8	110	13	187	14	17	110	56	150	85
Ø63	73	35	M30 x P1.5	45	25	10	56	35	79	50	3/8	115	13	202	14	17	126	68	155	95
Ø80	95	40	M30 x P1.5	50	25	15	64	40	83	50	3/8	125	13	225	18	20	152	75	190	120
Ø100	114	50	M40 x P2.0	55	25	20	78	40	94	60	1/2	150	15	255	20	20	180	100	220	140
Ø125	140	60	M50 x P2.0	70	35	20	78	50	109	70	1/2	160	15	295	24	30	222	122	280	170

1. The length and size of the piston rod were not specified when being enlarged or reduced, the size will be constructed according to the dimensions table.
2. When the stroke exceeds (includes) 1500 mm, see the specifications table for the length of the piston. Within 1499 mm (included) see the (PM) length of piston in the dimensions table.

HYDRAULIC CYLINDER

Dimensions

CROB CROB Type

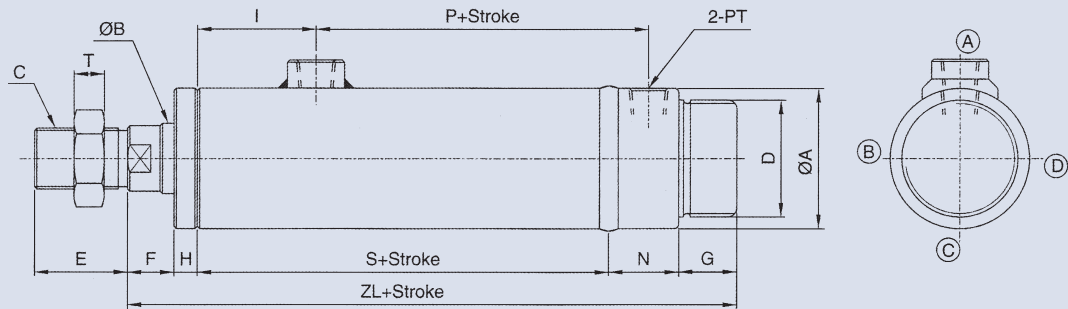

CROB Type

Bore \ Size	øA	øB	C	D	E	F	G	H	I	N	P	PM	PT	S	T	ZL
ø50	60	30	M26 x P1.5	M50 x P2.0	40	20	25	10	56	30	71	45	3/8	110	13	195
ø63	73	35	M30 x P1.5	M60 x P2.0	45	25	30	10	56	35	79	50	3/8	115	13	215
ø80	95	40	M30 x P1.5	M70 x P2.0	50	25	30	15	64	40	83	50	3/8	125	13	235
ø100	114	50	M40 x P2.0	M90 x P2.0	55	25	30	20	78	40	94	60	1/2	150	15	265
ø125	140	60	M50 x P2.0	M120 x P2.0	70	35	30	20	78	50	109	70	1/2	160	15	295

1. The length and size of the piston rod were not specified when being enlarged or reduced, the size will be constructed according to the dimensions table.
2. When the stroke exceeds (includes) 1500 mm, see the specifications table for the length of the piston. Within 1499 mm (included) see the (PM) length of piston in the dimensions table.

CROA CROA+TC Type

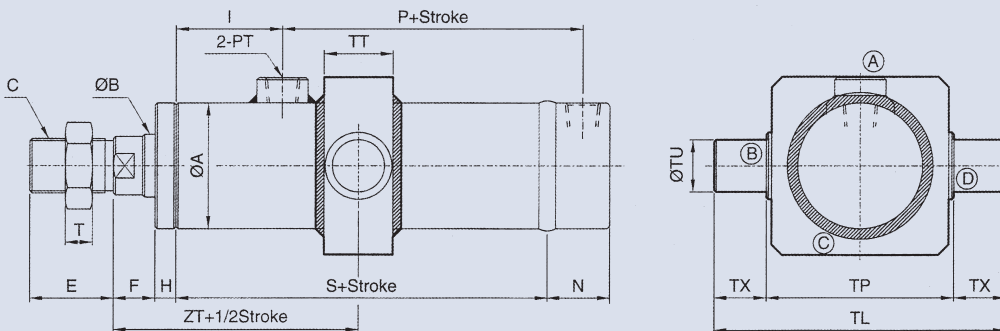

CROA Type

TC Type

Bore \ Size	øA	øB	C	E	F	H	I	N	P	PM	PT	S	T	ZT	øTU	TP	TL	TT	TX
ø50	60	30	M26 x P1.5	40	20	10	56	30	71	45	3/8	110	13	85	25	90	140	33	25
ø63	73	35	M30 x P1.5	45	25	10	56	35	79	50	3/8	115	13	92.5	32	102	166	40	32
ø80	95	40	M30 x P1.5	50	25	15	64	40	83	50	3/8	125	13	102.5	32	120	184	43	32
ø100	114	50	M40 x P2.0	55	25	20	78	40	94	60	1/2	150	15	120	40	140	220	53	40
ø125	140	60	M50 x P2.0	70	35	20	78	50	109	70	1/2	160	15	135	50	175	275	58	50

1. The length and size of the piston rod were not specified when being enlarged or reduced, the size will be constructed according to the dimensions table.
2. When the stroke exceeds (includes) 1500 mm, see the specifications table for the length of the piston. Within 1499 mm (included) see the (PM) length of piston in the dimensions table.

HYDRAULIC CYLINDER-ACCESSORIES

Dimensions

Adaptor I, Y

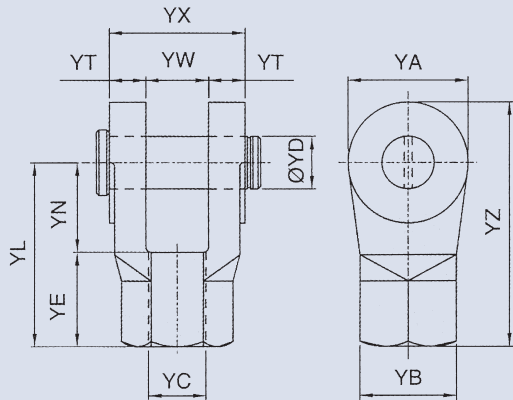

Y type adaptor with pin Material: FCD45 (ductile iron body)

Type	YA	YB	YC	YD	YE	YL	YN	YT	YW	YX	YZ
MY-014	29	27.5	M14 x P1.5	12	35	56	21	14	16	44	70
MY-016	29	27.5	M16 x P1.5	12	35	56	21	14	16	44	70
MY-018	29	27.5	M18 x P1.5	12	35	56	21	14	16	44	70
MY-022	46	37	M22 x P1.5	20	36	70	34	14	24	52	93
MY-026	52	42	M26 x P1.5	20	35	70	35	15	28	58	96
MY-030	55	42	M30 x P1.5	20	41	80	39	20	32	72	107
MY-030A	55	47	M30 x P1.5	25	41	80	39	22	40	84	107

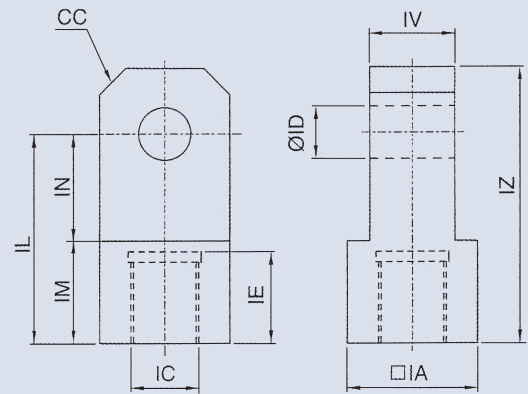

I type adaptor Material: SS41 (steel)

Type	IA	IC	ID	IE	IL	IM	IN	IV	IZ	CC
FI-018	32	M18 x P1.5	16	23	50	25	25	18	70	8
FI-022	40	M22 x P1.5	20	23	55	25	30	20	80	10
FI-026	50	M26 x P1.5	25	28	60	30	30	25	90	10
FI-036	60	M36 x P1.5	30	32	75	35	40	35	110	10
FI-045	70	M45 x P2.0	35	38	90	40	50	40	130	10

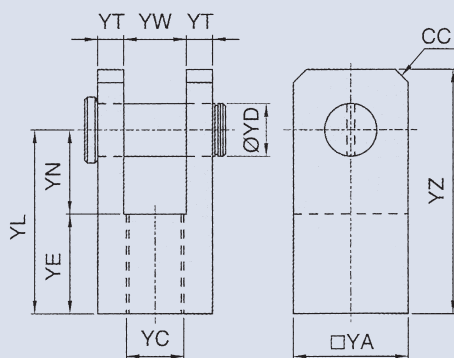

Y type adaptor with pin Material: SS41 (steel)

Type	YA	YC	YD	YE	YN	YL	YT	YW	YZ	CC
HY-014	32	M14 x P1.5	12	36	20	56	8	16	70	6
HY-016	32	M16 x P1.5	12	36	20	56	8	16	70	6
HY-018	38	M18 x P1.5	16	36	20	56	8	16	70	6
HY-022	44	M22 x P1.5	20	38	32	70	10	24	93	10
HY-026	50	M26 x P1.5	20	37	33	70	11.5	27	96	10
HY-030	60	M30 x P1.5	30	40	48	88	15	30	115	10
HY-040	70	M40 x P2.0	35	47	46	93	20	30	127	15
HY-050	80	M50 x P2.0	40	50	50	100	22.5	35	140	15
HY-070	115	M70 x P2.0	50	60	60	120	27.5	60	170	25
HY-090	150	M90 x P2.0	70	85	85	170	40	70	240	30

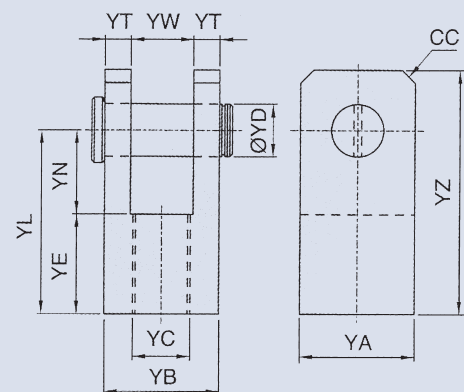

Y type adaptor with pin Material: SS41 (steel)

Type	YA	YB	YC	YD	YE	YN	YL	YT	YW	YZ	CC
FY-018	32	38	M18 x P1.5	16	25	25	50	10	18	70	8
FY-022	40	44	M22 x P1.5	20	25	30	55	12	20	80	10
FY-026	50	55	M26 x P1.5	25	30	30	60	15	25	90	15
FY-036	60	65	M36 x P1.5	30	35	40	75	15	35	110	15
FY-045	70	80	M45 x P2.0	35	40	50	90	20	40	135	15

HYDRAULIC CYLINDER-ACCESSORIES

Dimensions

Adaptor I, H, T

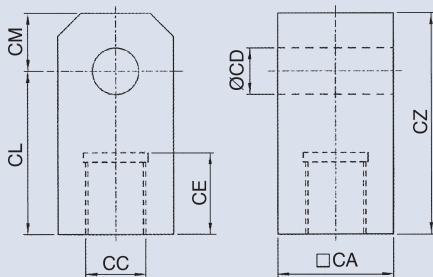

I type adaptor Material: SS41 (steel)

Type	CA	CC	CD	CE	CL	CM	CZ
CI-026	44.5	M26 x P1.5	25	40	60	25	85
CI-030	50.8	M30 x P1.5	30	45	70	30	100
CI-040	60	M40 x P2.0	30	50	75	30	105
CI-050	70	M50 x P2.0	35	55	85	35	120
CI-060	90	M60 x P2.0	50	70	105	50	155

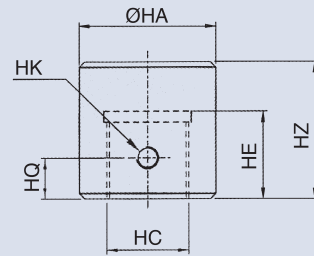

H type adaptor for welding Material: SS41 (steel)

Type	øHA	HC	HE	HK	HQ	HZ
HH-010	20	M10 x P1.25	20	M6 x P1.0	10	30
HH-014	35	M14 x P1.5	25	M8 x P1.25	12	40
HH-016	35	M16 x P1.5	25	M8 x P1.25	12	40
HH-018	35	M18 x P1.5	25	M8 x P1.25	12	40
HH-022	40	M22 x P1.5	32	M8 x P1.25	15	50
HH-026	45	M26 x P1.5	32	M8 x P1.25	15	50
HH-030	50	M30 x P1.5	35	M8 x P1.25	20	55
HH-036	55	M36 x P2.0	40	M8 x P1.25	20	60
HH-040	60	M40 x P2.0	48	M10 x P1.5	25	65
HH-045	70	M45 x P2.0	52	M10 x P1.5	25	70
HH-050	80	M50 x P2.0	55	M10 x P1.5	25	75
HH-060	90	M60 x P2.0	55	M10 x P1.5	30	80
HH-070	100	M70 x P2.0	65	M12 x P1.75	30	100
HH-090	140	M90 x P2.0	85	M12 x P1.75	40	120

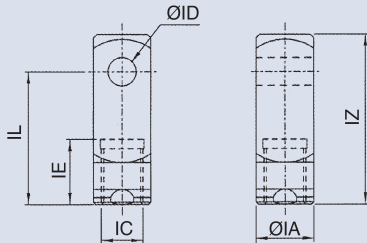

I type adaptor Material: SS41 (steel)

Type	IA	IC	ID	IE	IL	IZ
SI-014	25.4	M14 x P1.5	12	40	57	73
SI-016	25.4	M16 x P1.5	12	40	57	73
SI-018	25.4	M18 x P1.5	12	40	57	73
SI-022	31.75	M22 x P1.5	16	40	59	76

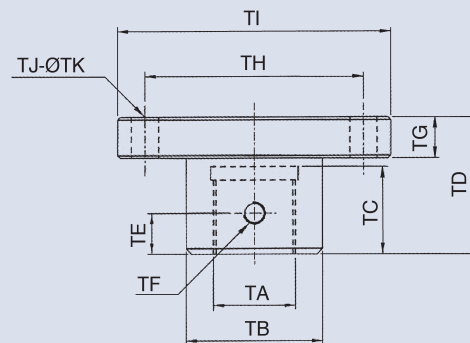

T type adaptor Material: SS41 (steel)

Type	TA	TB	TC	TD	TE	TF	TG	TH	TI	TJ	TK
HT-010	M10 x P1.25	20	20	30	10	M6 x P1.0	8	40	60	4	8
HT-014	M14 x P1.5	30	25	40	12	M8 x P1.25	10	55	80	4	10
HT-016	M16 x P1.5	30	25	40	12	M8 x P1.25	10	55	80	4	10
HT-018	M18 x P1.5	30	25	40	12	M8 x P1.25	10	55	80	4	10
HT-022	M22 x P1.5	35	32	50	15	M8 x P1.25	15	65	85	4	10
HT-026	M26 x P1.5	40	32	50	15	M8 x P1.25	15	70	90	4	10
HT-030	M30 x P1.5	55	35	55	20	M8 x P1.25	20	75	100	4	12
HT-036	M36 x P2.0	50	48	55	20	M8 x P1.25	20	80	105	4	12
HT-040	M40 x P2.0	60	48	65	25	M10 x P1.5	25	90	115	6	12
HT-045	M45 x P2.0	70	55	65	25	M10 x P1.5	25	100	125	6	12
HT-050	M50 x P2.0	80	55	75	25	M10 x P1.5	25	110	140	6	14
HT-060	M60 x P2.0	90	55	80	30	M10 x P1.5	30	120	150	6	14
HT-070	M70 x P2.0	100	65	100	30	M12 x P1.75	30	140	180	6	18
HT-090	M90 x P2.0	140	85	120	40	M12 x P1.75	40	180	220	6	18

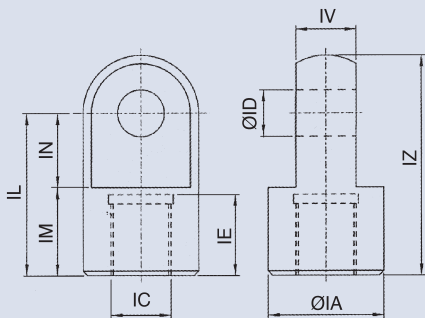

I type adaptor Material: SS41 (steel)

Type	IA	IC	øID	IE	IL	IM	IN	IV	IZ
HI-026	50	M26 x P1.5	25	40	85	45	40	30	110
HI-030	55	M30 x P1.5	25	40	83	45	38	35	110
HI-040	75	M40 x P2.0	35	50	90	40	50	45	130
HI-050	90	M50 x P2.0	50	60	105	50	55	55	150
HI-070	115	M70 x P2.0	60	65	120	65	55	60	177
HI-090	150	M90 x P2.0	70	82	180	90	90	70	250