



**Robust valve control device giving a confidence in reliable performance and outstanding durability under harsh working environments**

### Features

- ▶ Easy maintenance
- ▶ Precise calibration with simple SPAN and ZERO adjustments
- ▶ Simple conversion to direct acting or reverse acting
- ▶ 1/2 split range available
- ▶ Rugged aluminum housing with corrosion-resistant coating
- ▶ Vibration resistant design
- ▶ Stainless steel gauges standard
- ▶ Restricted pilot valve orifice kit for small actuators included

### Options

- ▶ High temperature

### Specifications

	PPL	
	Linear Type (Lever Feedback)	
	Single	Double
Input Signal	0.2 - 1.0 bar (3 - 15 psi) (Note.1, 2)	
Supply Air Pressure	Max. 7.0 bar (100 psi)	
Standard Stroke	10 - 80 mm (Note.3)	
Pneumatic Connections	PT(Rc) 1/4 or NPT 1/4	
Ambient Temperature	-20 ~ +70°C (Note. 4)	
Pressure Gauge	Stainless steel	
Output Characteristics	Linear	
Linearity	Within $\pm 1.0$ % F.S	Within $\pm 1.5$ % F.S
Sensitivity	Within $\pm 0.2$ % F.S	Within $\pm 0.5$ % F.S
Hysteresis	Within 1.0 % F.S	
Repeatability	Within $\pm 0.5$ % F.S	
Air Consumption	5 LPM (Sup. 1.4 bar)	
Flow Capacity	80 LPM (Sup. 1.4 bar)	
Body Material	Aluminium die-cast	
Weight	2.1 kg	

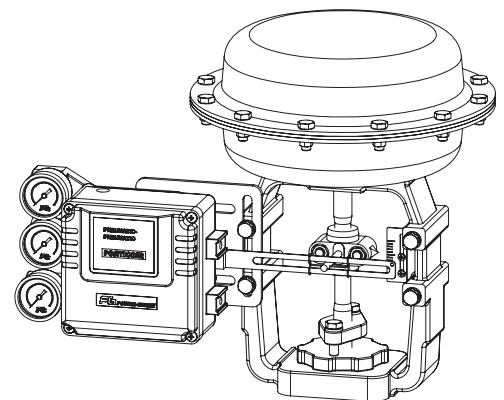

- Note** : 1) 1/2 split range is available for 3~9 psi input signal or 9~15 psi input signal  
 2) Please contact for 6~30 psi input signal  
 3) Feedback lever can be extended to stroke 80 ~ 150mm  
 4) High temperature option : up to +120 °C

## How to Order

**PPL** —

Feedback  
Lever

Pressure  
Gauge

Pilot  
Valve  
Orifice

Connection  
Threads

Operating  
Temperature

Mounting  
Bracket

Description	Code
<b>Feedback Lever :</b>	A : Stroke 10 ~ 40mm B : Stroke 10 ~ 80mm C : Stroke 80 ~ 150mm
<b>Pressure Gauge :</b>	1 : 6 bar (90psi) 2 : 10 bar (150psi)
<b>Pilot Valve Orifice :</b>	S : Standard (Actuator volume over 180cm <sup>3</sup> ) M : Small orifice (∅ 1.0 or ∅ 0.7) (Actuator volume 90 ~ 180cm <sup>3</sup> )

Description	Code
<b>Connection Threads :</b> (pneumatic)	3 : PT(Rc) 1/4 4 : NPT 1/4
<b>Operating Temperature :</b>	T : 70°C (standard) H : 120°C L : -40°C
<b>Mounting Bracket</b>	N : None L : DIN / IEC 60534-6-1

## Dimensions

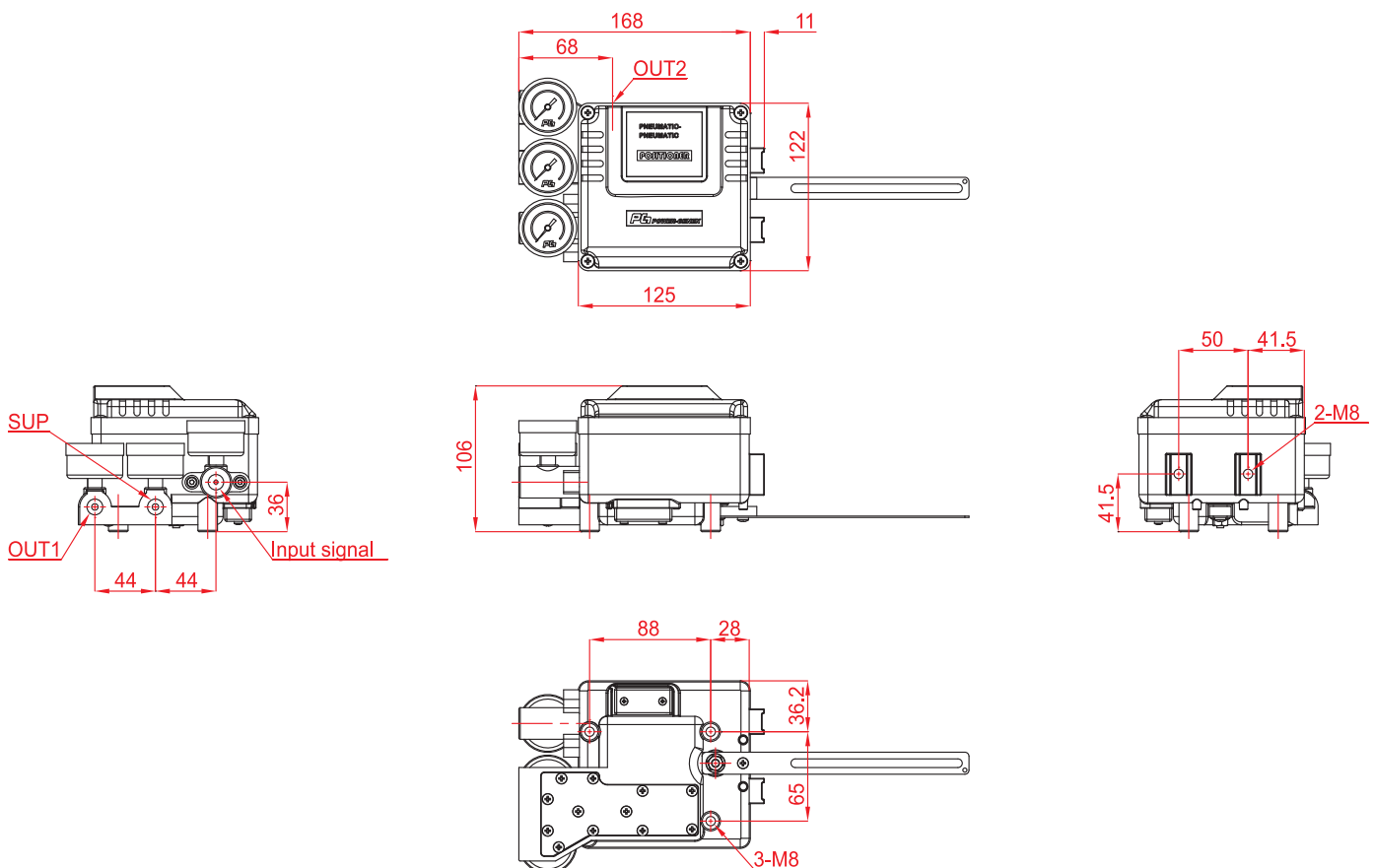

**Robust valve control device giving a confidence in reliable performance and outstanding durability under harsh working environments**



### Features

- ▶ Easy maintenance
- ▶ Precise calibration with simple SPAN and ZERO adjustments
- ▶ Simple conversion to direct acting or reverse acting
- ▶ 1/2 split range available
- ▶ Rugged aluminum housing with corrosion-resistant coating
- ▶ Vibration resistant design
- ▶ Stainless steel gauges standard
- ▶ Restricted pilot valve orifice kit for small actuators included

### Options

- ▶ Position transmitter (4-20mA output signal)
- ▶ 2 x SPDT limit switch
- ▶ 2 x P&F proximity sensor NJ2-V3-N
- ▶ Visual dome indicator
- ▶ High temperature

### Specifications

	PPR	
	Rotary Type (Cam Feedback)	
	Single	Double
Input Signal	0.2 - 1.0 bar (3 - 15 psi) (Note.1, 2)	
Supply Air Pressure	Max. 7.0 bar (100 psi)	
Standard Stroke	60 - 100° (Note.3)	
Pneumatic Connections	PT(Rc) 1/4 or NPT 1/4	
Ambient Temperature	-20 ~ +70°C (Note. 4)	
Pressure Gauge	Stainless steel	
Output Characteristics	Linear	
Linearity	Within ± 1.0 % F.S	Within ± 1.5 % F.S
Sensitivity	Within ± 0.5 % F.S	
Hysteresis	Within 1.0 % F.S	
Repeatability	Within ± 0.5 % F.S	
Air Consumption	5 LPM (Sup. 1.4 bar)	
Flow Capacity	80 LPM (Sup. 1.4 bar)	
Body Material	Aluminium die-cast	
Weight	2.5 kg	



**With Dome Indicator**

- Note** : 1) 1/2 split range is available for 3~9 psi input signal or 9~15 psi input signal  
 2) Please contact for 6~30 psi input signal  
 3) Operating angle can be adjusted to 0~60° or 0~100°  
 4) High temperature option : up to +120°C without feedback options  
 up to +85°C with feedback options

## How to Order

<b>PPR</b>	Feedback Lever	Pressure Gauge	Pilot Valve Orifice	Position Feedback	Connection Threads	Dome Indicator	Operating Temperature	Mounting Bracket
------------	----------------	----------------	---------------------	-------------------	--------------------	----------------	-----------------------	------------------

Description	Code
<b>Feedback Shaft :</b>	N : NAMUR shaft (direct mounting) A : Fork lever M6 x 40L B : Fork lever other size on request
<b>Pressure Gauge :</b>	1 : 6 bar (90psi) 2 : 10 bar (150psi)
<b>Pilot Valve Orifice :</b>	S : Standard (Actuator volume over 180cm <sup>3</sup> ) M : Small orifice (Ø 1.0 or Ø 0.7) (Actuator volume 90 ~ 180cm <sup>3</sup> )
<b>Position Feedback :</b>	N : None (standard) O : Position transmitter (4 ~ 20mA output signal) L : 2 x SPDT limit switch P : 2 x proximity sensor P&F NJ2-V3-N M : O + L Q : O + P

Description	Code
<b>Connection Threads :</b> (pneumatic)	3 : PT(Rc) 1/4 4 : NPT 1/4
<b>Dome Indicaotr :</b>	N : Flat indicator (standard) D : Dome indicator
<b>Operating Temperature :</b>	T : 70°C (standard) H : 120°C (without position feedback option) 85°C (with position feedback option) L : -40°C (without position feedback option)
<b>Mounting Bracket</b> <b>- NAMUR Shaft Type :</b>	N : None R : Multi-size NAMUR bracket for DIN VDI/VE 3845 (130 x 30 x 50 bracket on request)
<b>- Fork Lever Type</b>	F : DHCT bracket 80x30 for fork lever type E : Multi-size NAMUR bracket for Fork lever type (130 x 30 x 50 bracket on request)

## Dimensions

### A. With Flat Indicator

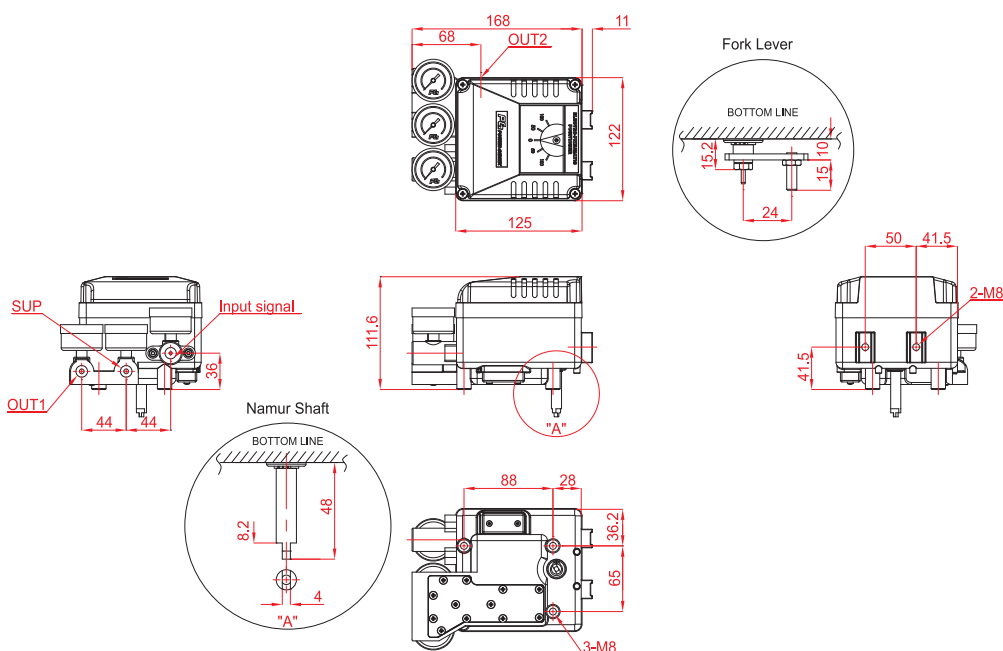

### B. With Dome Indicator

