

Contents

A series
Part List

A series
Selection guide
Dimension

A series
Torque table

R series
Part list

R series
Selection guide
Dimension

R series
Torque table

Various option

Limit switch
box

Positioner

► Part list

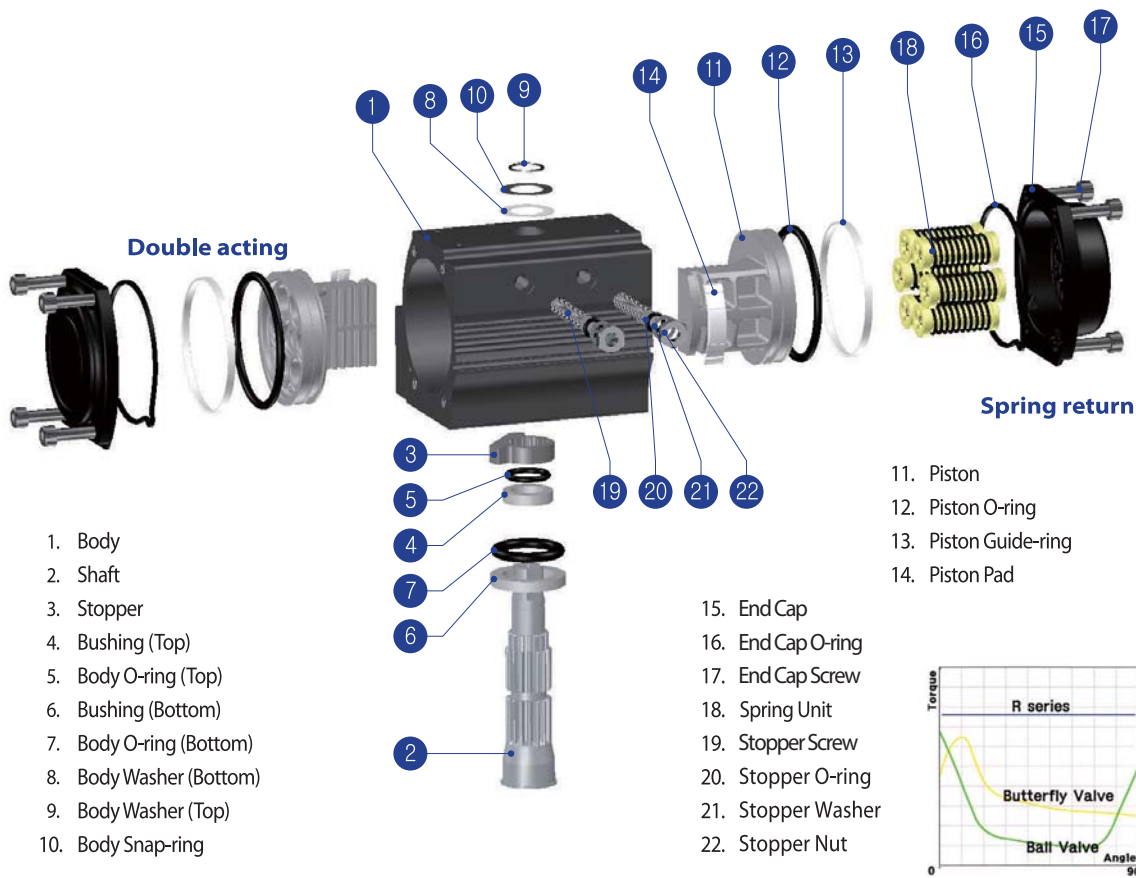

► Operating mechanism

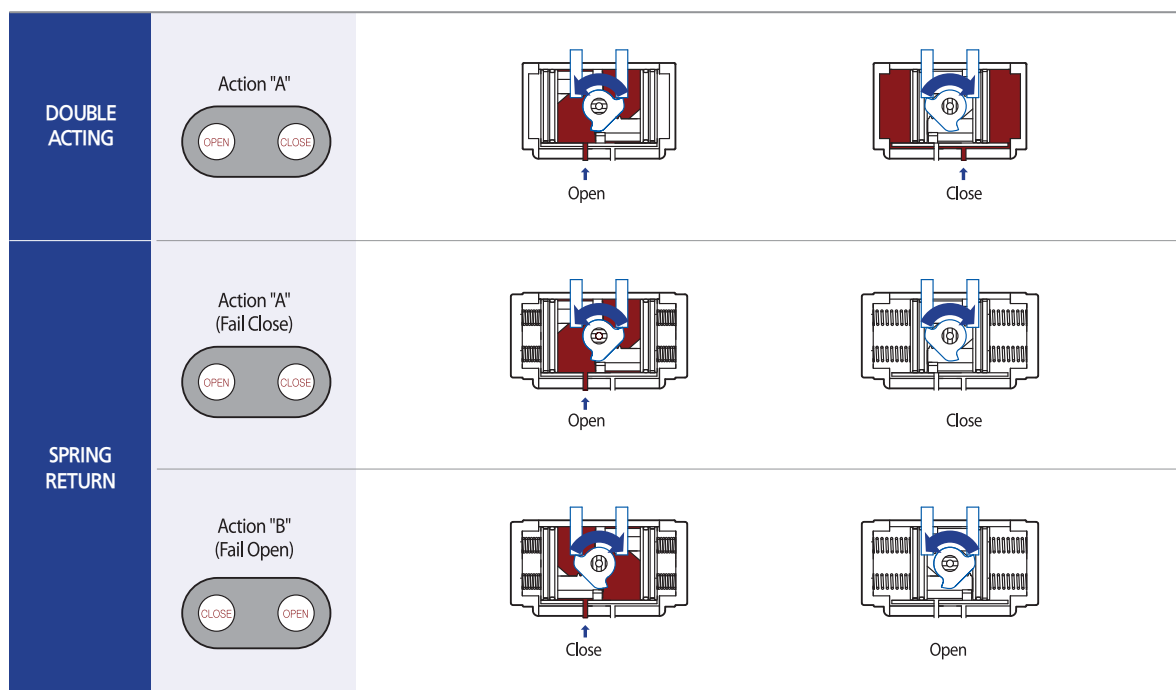

► Selection guide

Contents

A series
Part list

A series
Selection guide
Dimension

A series
Torque table

R series
Part list

R series
Selection guide
Dimension

R series
Torque table

Various option

Limit switch
box

Positioner

Valve Size		Double acting		Spring return	
		Ball valve	Butterly valve	Ball valve	Butterly valve
1/2"	15A	RD32 (1piece)	RD50	RS40	
3/4"	20A	RD40 (1piece)		RS50	
1"	25A		RD65	RS65	
1-1/4"	32A			RS80	
1-1/2"	40A		RD80	RS90	RS50
2"	50A			RD65	RS100
2-1/2"	65A		RD90		RS115
3"	80A		RD100 / RD115	RS125	RS90
4"	100A			RD115 / RD125	RS140
5"	125A		RD140	RS160 / RS185	RS115
6"	150A		RD160	RS185 / RS210	RS125
8"	200A		RD185	RD125	RS140
10"	250A		RD210	RD140	RS160
12"	300A			RD160	RS185
14"	350A			RD185	RS210
16"	400A			RD210	

•Based on 10K/#150

•The above data is for reference only; the actual assembly may be different depending on valve material, pressure, structure, fluid and operational environment.

•The data is not legally effective and therefore should not be used as legal ground.

► Dimension table

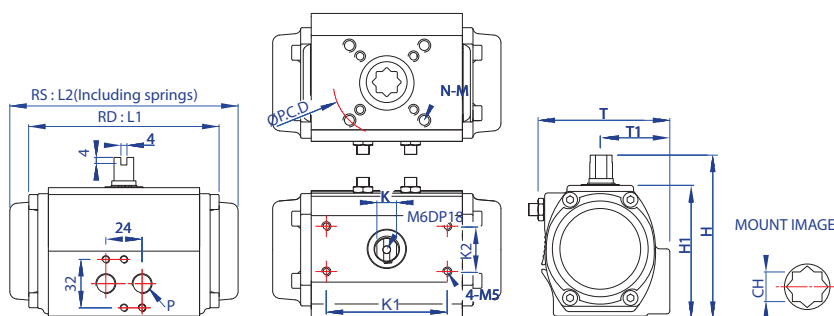

P		
R32,R40	PT1/8	
R50~R210	PT1/4	
	K1	K2
R32	25,5	25,5
R40	50	25
R50~R160	80	30
R210	130	30

※Unit:mm

MODEL	ISO	P.C.D.(∅)	N-G	K	RD L1	RS L2	T	T1	H	H1	CH	Stem depth	RD Wt(Kg)	RS Wt(Kg)
@RD32	F03	36	4-M5	7	66	-	45	25	55	45	9*9	9	0.3	-
@R40	F03/F05	36/50	4-M5/M6	9	97	97	63	32	75	55	9*9	9	0.5	0.6
	#F04	#42	#4-M5											
R50	F03/F05/F07	36/50/70	4-M5/M6/M8	9	119	133	75	40	90	70	11*11	13	1.0	1.1
	#F04	#42	#4-M5											
R65	F05/F07	50/70	4-M6/M8	13	131	154	89	46	106.5	86.5	14*14	16	1.4	1.5
	#F07	#70	#4-M8											
R80	F07	70	4-M8	19	189	220	101	49.5	126	106	17*17	19	2.9	3.3
R90	F07	70	4-M8	19	188	223	104	54.5	136	116	17*17	19	3.4	3.8
R100	F07/F10	70/102	4-M8/M10	19	229	256	132	61.5	148	128	22*22	26	4.7	5.4
											#17*17	19		
R115	F07/F10	70/102	4-M8/M10	19	264	302	137	67.5	163	143	22*22	26	6.7	5.4
R125	F07/F10	70/102	4-M8/M10	19	299	330	151	71.5	174	154	22*22	26	8.6	9.9
R140	F10/F12	102/125	4-M10/M12	25	332	389	164	77	192	172	27*27	30	12.4	14.5
											#22*22	26		
R160	F10/F12	102/125	4-M10/M12	24	364	416	188	103.5	216	196	27*27	30	16.9	19.5
R185	F10/F12	102/125	4-M10/M12	24	434	465	217	103	244	224	36*36	30	24.2	29.0
R210	F14	140	4-M12	36	444	527	231	115	284	254	36*36	30	32.3	37.9

#Option

Contents

► RD series Torque table

※ Unit : Nm

MODEL	Supply air						
	3Bar	4Bar	4.5Bar	5Bar	6Bar	7Bar	8Bar
RD32	2.4	3.1	3.5	3.9	4.8	5.7	6.6
RD40	5.5	7.4	8.4	9.2	11.1	13.0	14.8
RD50	9.4	12.5	14.3	15.9	19.1	22.5	25.8
RD65	18.3	24.7	27.8	30.8	36.8	42.9	49.2
RD80	44.5	58.9	66.5	74.4	89.3	104.3	117.8
RD90	57.2	76.2	85.7	95.2	114.2	133.2	152.2
RD100	79.5	105.5	118.8	132.1	158.7	185.3	211.9
RD115	123.5	166.3	187.2	209.0	251.8	294.5	337.3
RD125	161.5	218.5	247.0	270.8	327.8	384.8	437.0
RD140	237.5	318.3	361.0	399.0	479.8	560.5	641.3
RD160	327.8	441.8	494.0	551.0	669.8	779.0	893.0
RD185	475.0	641.3	722.0	802.8	964.3	1,125.8	1,287.3
RD210	679.3	912.0	1,030.8	1,144.8	1,382.3	1,615.0	1,847.8

※ 0° -Valve Closed / 90° -Valve open

► RS series Torque table

※Unit : Nm

Model	Spring unit	Supply air (to Open)															
		3Bar		4Bar		4.5Bar		5Bar		6Bar		7Bar		8Bar		Spring to Close	
		0°	90°	0°	90°	0°	90°	0°	90°	0°	90°	0°	90°	0°	90°	90°	0°
RS40	WM	3.2	1.5	5.0	3.1	5.0	3.8	6.0	4.6	6.9	5.9	8.8	7.1	10.7	8.2	2.4	1.6
	WS	2.7	0.7	4.6	1.7	5.4	2.3	6.4	2.9	8.2	4.1	10.1	5.2	12.0	6.3	3.0	2.1
	M	2.6	0.8	4.6	2.4	5.4	3.2	6.3	4.1	8.1	5.9	10.0	7.7	11.9	9.3	4.1	2.8
	MS	1.9	-	3.7	1.0	4.6	1.8	5.4	2.5	7.3	4.2	9.1	5.6	11.0	6.7	4.9	3.0
	S*	1.0	-	2.9	0.5	3.8	1.2	4.8	2.1	6.7	3.8	8.6	5.1	10.5	6.4	5.9	3.9
RS50	4	7.4	6.1	10.8	9.5	12.4	11.1	14.2	12.8	17.5	16.2	20.9	19.6	24.1	22.9	3.6	2.3
	5	6.7	5.0	10.2	8.5	11.9	10.2	13.4	11.8	16.8	15.3	20.1	18.5	23.6	22.0	4.4	2.8
	6	6.3	4.0	9.6	7.5	11.3	9.0	12.8	10.7	16.3	14.3	19.6	17.6	22.9	20.9	5.2	3.3
	7	5.6	3.2	8.9	6.6	10.6	8.4	12.3	10.0	15.6	13.4	19.0	16.8	22.4	20.2	6.3	3.8
	8*	4.1	1.2	7.4	4.4	9.0	6.1	10.7	7.6	14.2	11.1	17.3	14.5	20.8	18.0	8.1	5.2
	9	3.6	-	6.9	3.4	8.6	5.2	10.3	6.9	13.6	10.2	16.9	13.6	20.3	17.0	9.1	6.0
	10	2.9	-	6.1	2.7	7.8	4.3	9.5	5.9	12.8	9.3	16.2	12.6	19.5	16.1	10.1	6.5
	11	2.3	-	5.6	1.5	7.3	3.1	8.9	4.8	12.4	8.2	15.7	11.5	19.0	14.9	11.0	7.0
RS65	4	7.4	6.1	13.7	10.5	19.7	16.8	22.8	20.0	26.0	23.1	32.2	29.5	38.4	35.5	6.7	4.0
	5	6.7	5.0	12.4	9.0	18.7	15.3	21.9	18.4	24.8	21.7	31.1	27.8	37.2	34.3	8.5	5.2
	6	6.3	4.0	11.0	6.9	17.1	13.3	20.1	16.4	23.3	19.6	29.5	26.0	35.7	32.0	9.8	6.5
	7	5.6	3.2	10.0	5.2	16.2	11.4	19.3	14.4	22.2	17.4	28.4	23.6	35.0	29.9	11.4	7.1
	8*	4.1	1.2	8.7	3.6	14.7	9.5	17.9	12.5	21.1	15.7	27.2	22.0	33.3	28.1	13.7	8.4
	9	3.6	-	7.6	1.3	14	7.5	17.1	10.7	20	13.8	26.3	20.0	32.4	26.4	15.2	9.7
	10	2.9	-	6.1	-	12.3	5.3	15.4	8.6	18.5	11.8	24.7	18.1	30.4	24.3	17.4	11.0
	11	2.3	-	5.4	-	11.4	3.8	14.4	7.6	17.6	10.4	23.8	16.7	30.0	22.8	18.6	12.2
RS80	4	32.7	25.1	47.9	40.4	55.1	47.2	62.5	55.1	77.8	70.5	92.6	85.3	107.4	100.1	16.3	10.6
	5	29.5	19.9	44.7	35.0	52.3	41.9	59.8	49.6	74.8	64.8	89.3	79.8	104.2	94.7	20.9	13.1
	6	26.6	15.2	41.3	30.1	49.4	37.1	56.6	44.9	71.4	59.9	86.2	74.9	101.5	89.9	25.3	16.2
	7	23.7	10.2	38.4	25.7	45.8	32.1	53.1	39.9	68.2	55.1	83.1	69.8	98.0	84.9	29.5	18.6
	8*	21.1	6.1	35.3	21.0	42.9	29.1	50.5	35.7	65.6	51.3	80.8	66.4	95.7	80.5	33.7	21.7
	9	17.6	-	32.4	15.7	39.9	23.8	47.4	30.4	62.4	45.3	77.7	60.1	92.5	75.1	38.3	24.8
	10	14.3	-	29.5	11.0	37.1	19	44.3	25.7	59.8	40.4	74.5	55.5	89.2	70.0	43.7	28.2
	11	11.4	-	26.2	5.7	33.4	12.9	40.5	20.4	56.1	35.3	70.8	49.9	85.8	64.4	47.7	30.3
12	9.1	-	23.7	1.0	32.2	8.6	38.5	16.2	53.9	30.7	68.9	44.8	83.6	60.1	51.6	33.5	

※0° -Valve Closed / 90° -Valve open

*Standard

Contents

A series
Part List

A series
Selection guide
Dimension

A series
Torque table

R series
Part list

R series
Selection guide
Dimension

R series
Torque table

Various option

Limit switch
box

Positioner

Contents

 A series
Part List

 A series
Selection guide
Dimension

 A series
Torque table

 R series
Part list

 R series
Selection guide
Dimension

 R series
Torque table

Various option

 Limit switch
box

Positioner

Model	Spring unit	Supply Air																
		3Bar		4Bar		4.5Bar		5Bar		6Bar		7Bar		8Bar		Spring to Close		
		0°	90°	0°	90°	0°	90°	0°	90°	0°	90°	0°	90°	0°	90°	90°	0°	
RS90	4	41.8	30.9	61.3	49.9	70.3	59.4	79.8	69.8	98.8	88.8	117.8	107.8	136.8	126.8	22.2	12.8	
	5	38.7	25.0	58.3	44.3	67.5	54.0	77.0	63.7	96.0	82.9	115.0	102.3	134.0	120.9	26.4	16.3	
	6	34.9	19.0	54.7	38.0	64.2	47.5	73.7	57.0	92.7	77.0	111.7	96.0	130.7	115.0	33.9	20.2	
	7	31.2	12.7	50.5	32.3	60.0	41.8	69.8	51.3	88.8	70.8	107.8	89.8	126.8	108.8	38.4	23.4	
	8*	27.7	6.7	47.3	25.7	56.6	35.2	65.8	44.7	85.1	63.7	104.1	82.7	123.1	101.7	43.9	27.2	
	9	23.1	-	42.5	18.8	51.6	28.9	61.4	38.0	80.8	57.4	100.0	77.0	119.0	96.0	49.8	30.7	
	10	19.2	-	38.0	12.7	47.5	21.9	57.0	31.4	76.0	50.8	95.0	69.8	114.0	89.0	56.5	34.5	
	11	16.9	-	35.0	6.5	44.4	16.2	54.0	25.7	73.2	44.7	92.2	63.7	111.2	82.7	61.8	37.8	
	12	12.8	-	31.5	-	41.5	9.5	50.0	19.2	69.4	38.0	88.6	57.0	107.4	76.5	67.5	40.7	
	RS100	4	57.7	41.1	84.3	67.8	97.7	81.3	106.4	95.3	133.0	121.6	159.6	148.2	186.2	174.8	33.1	20.7
		5	51.5	31.2	78.9	58.3	93.6	71.7	104.8	85.2	131.1	112.1	157.7	138.7	184.3	165.3	41.8	25.5
		6	45.8	22.1	72.7	48.5	85.5	62.2	98.6	75.5	125.4	101.7	152.0	128.3	178.6	154.9	50.8	31.2
7		40.6	12.4	67.0	38.6	80.2	53.6	93.5	66.0	119.7	92.2	146.3	118.8	172.9	145.4	59.3	36.2	
8*		34.9	4.8	60.8	29.6	74.1	43.7	86.7	56.1	113.1	81.9	139.7	108.3	166.3	135.9	67.6	40.9	
9		30.6	-	57.0	20.9	70.3	33.7	83.1	46.6	109.3	74.1	135.9	100.2	162.5	126.4	76.4	45.6	
10		25.2	-	52.7	11.8	66.9	24.1	79.3	36.9	105.5	64.1	132.1	90.0	158.7	116.9	87.2	50.4	
11		20.5	-	46.4	1.9	59.5	14.3	72.4	28.0	98.6	53.8	125.4	79.3	152.0	105.5	93.8	55.7	
12		13.8	-	40.3	-	52.9	4.8	65.6	19.0	92.6	45.8	119.2	71.2	145.8	97.9	102.0	60.6	
RS115		4	95.0	71.3	137.8	114.0	161.5	137.8	180.5	161.5	223.3	204.3	266.0	247.0	308.8	289.8	42.8	23.8
		5	85.5	61.8	128.3	104.5	147.3	123.5	171.0	147.3	213.8	190.0	256.5	232.8	299.3	275.5	52.3	33.3
		6	76.0	52.3	118.8	90.3	142.5	114.0	161.5	133.0	204.3	175.8	247.0	218.5	289.8	261.3	61.8	38.0
	7	66.5	33.3	114.0	76.0	133.0	99.8	156.8	118.8	194.8	161.5	237.5	204.3	285.0	247.0	76.0	47.5	
	8*	61.8	23.8	104.5	66.5	128.3	85.5	147.3	109.3	190.0	152.0	232.8	190.0	275.5	237.5	85.5	52.3	
	9	52.3	9.5	95.0	52.3	118.8	71.3	137.8	95.0	185.3	142.5	228.0	180.5	270.8	223.3	99.8	61.8	
	10	42.8	-	85.5	42.8	109.3	61.8	128.3	80.8	175.8	123.5	218.5	166.3	256.5	209.0	114.0	66.5	
	11	38.0	-	80.8	28.5	104.5	47.5	123.5	71.3	166.3	114.0	209.0	156.8	251.8	199.5	123.5	76.0	
	12	33.3	-	71.3	14.3	95.0	38.0	114.0	57.0	156.8	99.8	199.5	142.5	242.3	185.3	133.0	80.8	
	RS125	4	114.0	95.0	171.0	152.0	194.8	180.5	223.3	209.0	275.5	261.3	327.8	318.3	384.8	375.3	57.0	33.3
		5	104.5	80.8	161.5	133.0	190.0	161.5	213.8	190.0	270.8	247.0	327.8	304.0	380.0	356.3	71.3	42.8
		6	95.0	61.8	152.0	118.8	175.8	147.3	204.3	171.0	256.5	228.0	313.5	285.0	370.5	337.3	85.5	52.3
7		85.5	47.5	142.5	99.8	166.3	128.3	194.8	156.8	247.0	213.8	304.0	266.0	356.3	323	99.8	61.8	
8*		76.0	28.5	128.3	80.8	156.8	109.3	180.5	137.8	237.5	194.8	289.8	247.0	346.8	304.0	114.0	71.3	
9		66.5	9.5	118.8	66.5	147.3	95.0	175.8	123.5	228.0	175.8	280.3	232.8	332.5	285.0	133.0	85.5	
10		52.3	-	109.3	47.5	137.8	76.0	161.5	104.5	218.5	161.5	270.8	213.8	323.0	270.8	147.3	95.0	
11		42.8	-	99.8	33.3	128.3	61.8	152.0	85.5	209.0	142.5	261.3	199.5	313.5	251.8	161.5	104.5	
12		33.3	-	90.3	19.0	114.0	42.8	142.5	71.3	194.8	123.5	251.8	180.5	304.0	232.8	175.8	114.0	

※ 0° -Valve Closed / 90° -Valve open

※Unit : Nm

Model	Spring unit	Supply Air																
		3Bar		4Bar		4.5Bar		5Bar		6Bar		7Bar		8Bar		Spring to Close		
		0°	90°	0°	90°	0°	90°	0°	90°	0°	90°	0°	90°	0°	90°	90°	0°	
RS140	4	166.3	137.8	247.0	218.5	285.0	261.3	327.8	299.3	408.5	384.8	489.3	465.5	570.0	546.3	760.0	52.3	
	5	156.8	109.3	237.5	194.8	280.3	232.8	318.3	275.5	399.0	361.0	479.8	441.8	560.5	522.5	104.5	61.8	
	6	142.5	90.3	223.3	175.8	261.3	213.8	304.0	256.5	384.8	337.3	465.5	418.0	546.3	498.8	123.5	71.3	
	7	128.3	66.5	209.0	147.3	247.0	190.0	289.8	228.0	370.5	313.5	451.3	394.3	532.0	470.3	147.3	90.3	
	8*	114.0	42.8	194.8	123.5	237.5	166.3	275.5	204.3	356.3	289.8	437.0	370.5	517.8	451.3	175.8	104.5	
	9	95.0	14.3	175.8	99.8	218.5	142.5	256.5	180.5	337.3	266.0	418.0	346.8	498.8	427.5	194.8	118.8	
	10	85.5	—	166.3	76.0	204.3	118.8	242.3	156.8	323.0	242.3	408.5	323.0	484.5	403.8	218.5	137.8	
	11	66.5	—	147.3	47.5	190.0	90.3	228.0	133.0	308.8	213.8	389.5	299.3	470.3	380.0	242.3	152.0	
	12	52.3	—	133.0	28.5	175.8	66.5	213.8	109.3	294.5	194.8	375.3	275.5	456.0	356.3	266.0	166.3	
	RS160	4	223.3	180.5	337.3	289.8	394.3	346.8	451.3	403.8	565.3	513.0	679.3	622.3	793.3	731.5	114.0	80.8
		5	213.8	152.0	327.8	261.3	384.8	318.3	441.8	375.3	555.8	484.5	669.8	593.8	783.8	703.0	142.5	95.0
		6	190.0	118.8	304.0	237.5	361.0	294.5	418.0	346.8	532.0	465.5	646.0	579.5	760.0	693.5	175.8	118.8
7		166.3	85.5	285.0	194.8	337.3	251.8	394.3	334.4	513.0	422.8	622.3	541.5	736.3	660.3	204.3	137.8	
8*		147.3	52.3	261.3	166.3	318.3	218.5	375.3	280.3	489.3	394.3	603.3	508.3	712.5	622.3	242.3	161.5	
9		123.5	14.3	242.3	128.3	299.3	185.3	356.3	242.3	470.3	356.3	584.3	470.3	698.3	584.3	275.5	185.3	
10		104.5	—	218.5	99.8	270.8	152.0	327.8	209.0	446.5	323.0	560.5	437.0	669.8	551.0	313.5	204.3	
11		80.8	—	194.8	61.8	251.8	114.0	308.8	175.8	422.8	289.8	532.0	403.8	650.8	517.8	337.3	228.0	
12		66.5	—	175.8	28.5	232.8	85.5	289.8	142.5	403.8	256.5	513.0	365.8	627.0	479.8	365.8	247.0	
RS185		4	342.0	270.8	503.5	432.3	584.3	513.0	665.0	593.8	826.5	755.3	988.0	912.0	1,144.8	1,073.5	180.5	118.8
		5	308.8	218.5	470.3	384.8	551.0	460.8	627.0	546.3	788.5	707.8	950.0	869.3	1,111.5	1,026.0	228.0	152.0
		6	270.8	166.3	437.0	332.5	517.8	408.5	598.5	489.3	760.0	650.8	916.8	812.3	1,078.3	969.0	280.3	190.0
	7	242.3	114.0	403.8	285.0	484.5	361.0	565.3	441.8	726.8	598.5	883.5	760.0	1,045.0	921.5	318.3	218.5	
	8*	204.3	66.5	365.8	228.0	446.5	304.0	532.0	384.8	693.5	546.3	850.3	703.0	1,011.8	864.5	370.5	251.8	
	9	171.0	9.5	337.3	171.0	418.0	251.8	494.0	332.5	660.3	494.0	821.8	660.3	978.5	817.0	422.8	285.0	
	10	137.8	—	304.0	118.8	384.8	199.5	460.8	280.3	627.0	446.5	788.5	608.0	945.3	769.5	465.5	318.3	
	11	104.5	—	266.0	61.8	346.8	152.0	427.5	232.8	593.8	394.3	750.5	555.8	912.0	712.5	508.3	346.8	
	12	71.3	—	232.8	23.8	313.5	99.8	394.3	180.5	555.8	342.0	717.3	498.8	874.0	655.5	560.5	380.0	
	RS210	4	503.5	408.5	736.3	646.0	850.3	760.0	959.5	878.8	1,201.8	1,111.5	1,434.5	1,339.5	1,667.3	1,572.3	232.8	156.8
		5	465.5	346.8	698.3	589.0	812.3	698.3	931.0	817.0	1,163.8	1,054.5	1,396.5	1,282.5	1,629.3	1,857.3	299.3	199.5
		6	422.8	280.3	660.3	517.8	774.3	631.8	888.3	750.5	1,125.8	988.0	1,358.5	1,235.0	1,586.5	1,458.3	361.0	242.3
7		375.3	213.8	612.8	446.5	726.8	565.3	845.5	684.0	1,078.3	916.8	1,311.0	1,149.5	1,539.0	1,391.8	422.8	285.0	
8*		332.5	152.0	570.0	380.0	684.0	498.8	802.8	617.5	1,035.5	850.3	1,263.5	1,078.3	1,496.3	1,311.0	489.3	327.8	
9		285.0	76.0	517.8	313.5	636.5	432.3	750.5	546.3	988.0	779.0	1,216.0	1,016.5	1,448.8	1,244.5	555.8	375.3	
10		232.8	9.5	465.5	242.3	584.3	356.3	703.0	475.0	935.8	712.5	1,168.5	945.3	1,401.3	1,173.3	622.3	427.5	
11		185.3	—	422.8	175.8	532.0	294.5	655.5	408.5	888.3	646.0	1,121.0	878.8	1,353.8	1,111.5	684.0	465.5	
12		147.3	—	384.8	114.0	498.8	237.5	612.8	342.0	850.3	574.8	1,083.0	812.3	1,315.8	1,040.3	745.8	503.5	

※0° -Valve Closed / 90° -Valve open

*Standard

Contents

 A series
Part List

 A series
Selection guide
Dimension

 A series
Torque table

 R series
Part list

 R series
Selection guide
Dimension

 R series
Torque table

Various option

 Limit switch
box

Positioner

► Various option

Contents

A series
Part List

A series
Selection guide
Dimension

A series
Torque table

R series
Part list

R series
Selection guide
Dimension





R series
Torque table

Various option

Limit switch
box

Positioner

● Indicator

A	B	C	D
			
<ul style="list-style-type: none"> · It is fixed with screws. 	<p>Standard indicator</p> <ul style="list-style-type: none"> · It is possible to assemble the switch box in an indicator-mounted state. 	<ul style="list-style-type: none"> · To AR50~AR160 can be used with 1 size. · It is easy to recognize since size is big. 	<ul style="list-style-type: none"> · There is no discoloration with plastic 4 piece indicator system. *For R40/AR50~AR125

● Epoxy coated actuator



- Epoxy coated after hard anodized aluminum body.
- It is used for Chemical pipe line.

● Stainless steel actuator



- Body and end cap's material are stainless steel.
- Model range : RD65, RD90, RD125, RS65, RS90, RS125

● Side sensor



[Sensor Circuit Diagram]

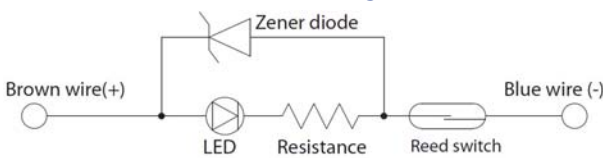

Sensor Specification	
Sensor	D-93K (KCC)
Application	Relay, PLC
Voltage	DC24V AC110V
Current range	5~40mA 5~20mA
Contact protection circuit	None
Internal voltage drop	≤2.7V
Indicator lamp	Red LED
Wire length	1m(standard), 3m, 5m

● Stopper

[Center stopper]

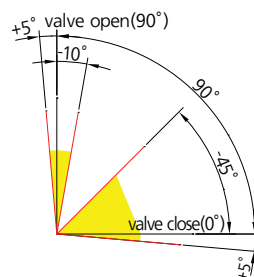
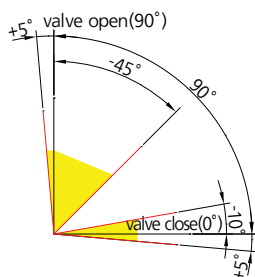

[End cap stopper]

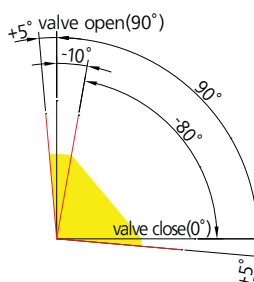
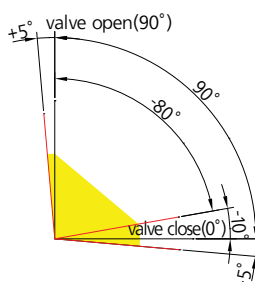

● Port pad



- Change Port size easily.
- Assemble other size NAUMUR solenoid valve with long screws.
- Add vent hole for quick response time in case of spring return.

● Adapter

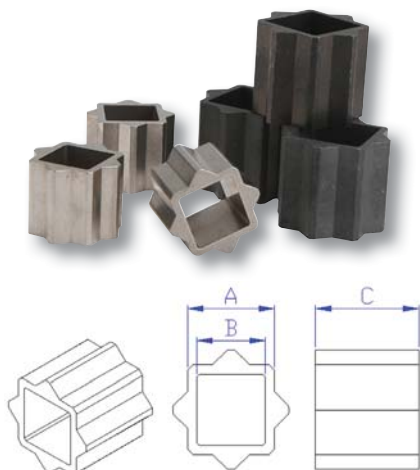

Double square			Single square		
A	B	C	A	B	C
11	9	12	11	9	10
14	9	15	14	9	15
14	11	15, 18	14	11	16, 15
17	14	18	17	11	17
17	11	18	17	14	17
22	14	24	22	17	22
22	17	24	27	22	27
27	17	27			
27	22	27			
36	27	38			

Contents

A series
Part List

A series
Selection guide
Dimension

A series
Torque table

R series
Part list

R series
Selection guide
Dimension

R series
Torque table

Various option

Limit switch
box

Positioner

● Side Hand Wheel

Contents

A series
Part List

A series
Selection guide
Dimension

A series
Torque table

R series
Part list

R series
Selection guide
Dimension

R series
Torque table

Various option

Limit switch
box

Positioner



· Can open or close valves by manual when air fails.

· Part list

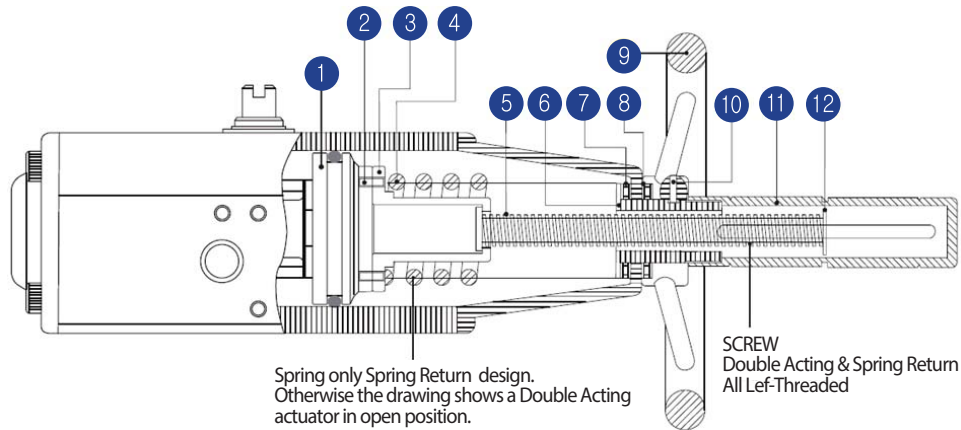

No.	1	2	3	4	5	6	7	8	9	10	11	12
Part	Piston	Screw Bolt	Spring Cap	Spring	Screw Stem	Stem Nuts	Needle Bearing	Plate	Handwheel	Set Screw	Protecting Tube	Indicator

· Dimension table

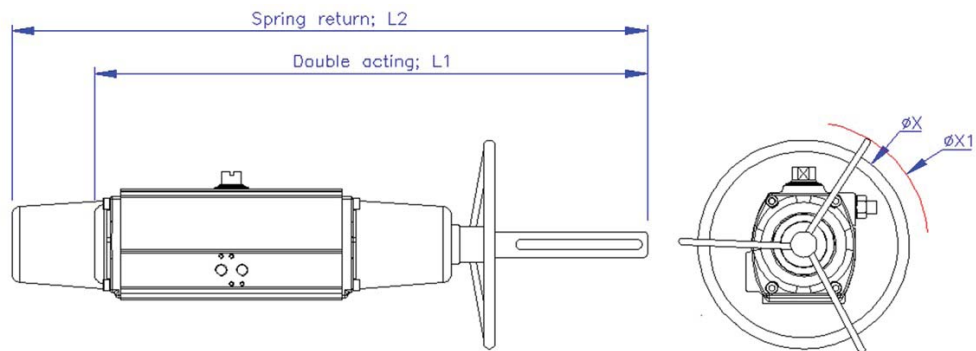

Model	L1	L2	X	X1	MODEL	L1	L2	X	X1
A50	315	410	127		A125	653	869	200	332
A65	396	512	162		A140	694	945	300	440
A80	460	628	202		A160	810	1085	300	440
A100	576	763	200	332	A210	948	1325	300	584

*Torque of Pneumatic actuator with side hand wheel is different with standard, Please contact our staff.