

FIN TUBE TYPE OIL COOLER NO-FIN TUBE TYPE OIL COOLER

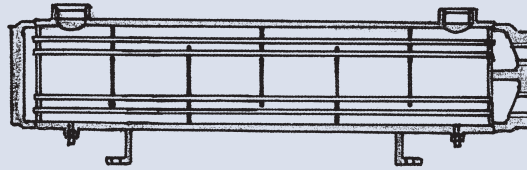
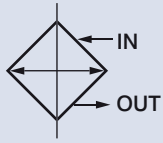

How to order

HT, HH - 14 05 - ✖

1 2 3 4

1	Model	HT: Fin tube type	HH: No-Fin tube type	HTF: Fin tube type	HHF: No-Fin tube type
2	Shell outside diameter				
3	Tube length				
4	Cooling water	None: Water (standard type)	B: Brine water		

Specifications

Model	Heat Diffusion Area(m ²)		Flow (lpm)	Weight(kg)	
	HT(F)	HH(F)		HT(F)	HH(F)
HT,HH-0905	0.41	0.24	60	10	10
HT,HH-0908	0.7	0.39	100	14	14
HT,HH-1405	1.1	0.54	150	20	20
HT,HH-1408	1.9	0.84	250	25	26
HT,HH-1412	2.9	1.28	350	37	35
HT,HH-1712	4.6	2.17	600	48	50
HT,HH-1716	6.5	2.89	840	56	60
HT,HH-1722	7.2	3.63	1000	72	72
HTF,HHF-2208	5.6	2.61	800	72	78
HTF,HHF-2212	8.6	4.02	1200	93	110
HTF,HHF-2216	11.6	5.39	1500	118	130
HTF,HHF-2222	14.6	7.15	1800	260	290

Model	Heat Diffusion Area(m ²)		Flow (lpm)	Weight(kg)	
	HTF	HHF		HTF	HHF
HTF,HHF-2508	8	3.55	1000	100	130
HTF,HHF-2512	12.2	5.41	1600	146	170
HTF,HHF-2516	16.4	7.21	1800	168	190
HTF,HHF-2522	20.8	9.08	2200	260	300
HTF-3208	13.3	-	1400	167	-
HTF-3212	20	-	2100	204	-
HTF-3216	26.6	-	2800	241	-
HTF-3222	33.4	-	3500	280	-
HTF-3508	15.5	-	1640	222	-
HTF-3512	23.6	-	2500	264	-
HTF-3516	31.5	-	3300	306	-
HTF-3522	39.6	-	4400	348	-

Dimensions

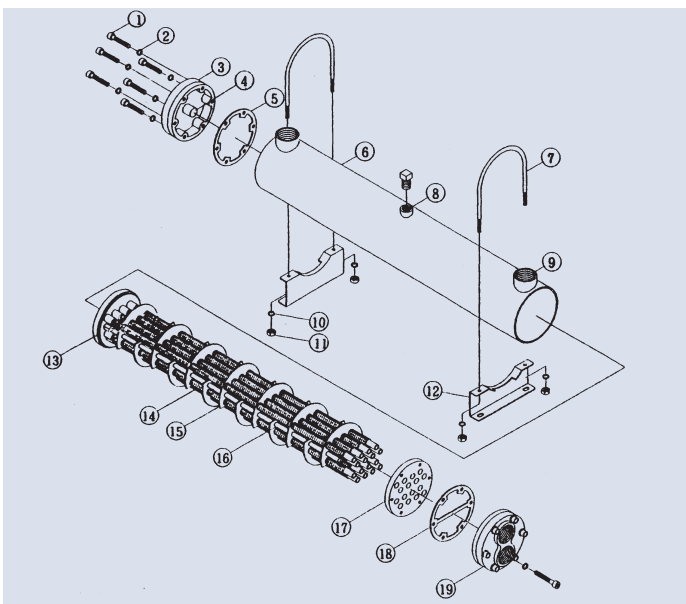

Item	Part name	Material
1	Socket cap screws	SCM (435)
2	Washers	SPM
3	Cast iron end cover	FC20
4	Anti-corrosion zinc bar	ZnB
5	Oil seal	NBR
6	Shell	BPE
7	Supporting hangers	AISI (1006)
8	Air vent	SS41
9	Oil port	STPG (370)
10	Vibration absorber	FWL
11	Nut	STEEL
12	Supporting legs	SS41
13	Tube end plate	SS41
14	Copper tubes	JIS (H3300) (1220T)
15	Baffle plates	SS41
16	Supporting rod	SS41
17	Tube bundle end plate	SS41
18	Oil seal	NBR
19	Cast Iron end cover	FC20

FIN TUBE TYPE OIL COOLER NO-FIN TUBE TYPE OIL COOLER

Dimensions

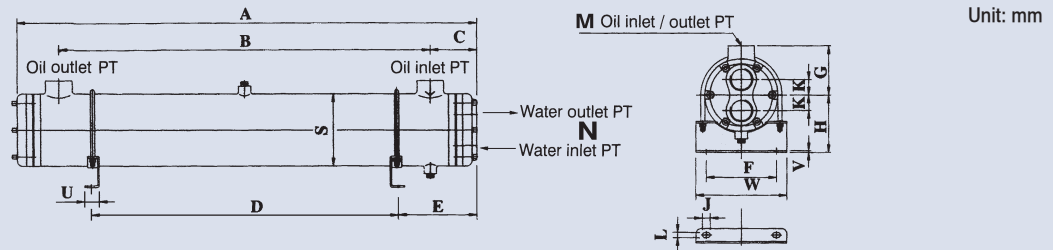

Model	A	B	C	D	E	F	J	G	H	K	L	M	N	S	U	V	W
HT,HH-0905	590	408	88	270	150	80	25	63	80	22	10	3/4"	3/4"	89.5	30	2.3	115
HT,HH-0908	880	720	78	500	190	80	25	63	80	22	10	3/4"	3/4"	89.5	30	2.3	115
HT,HH-1405	600	398	100	270	162	140	32	90	110	28	12	1-1/4"	1/1/4"	140.8	40	3.2	176
HT,HH-1408	890	710	85	500	202	140	32	90	110	28	12	1-1/4"	1-1/4"	140.8	40	3.2	176
HT,HH-1412	1310	1110	100	700	303	140	32	90	110	28	12	1-1/2"	1-1/4"	140.8	40	3.2	176
HT,HH-1712	1335	1060	138	700	310	145	32	115	125	32	12	2"	1-1/4"	166.5	40	3.2	200
HT,HH-1716	1745	1510	118	850	460	145	32	115	125	32	12	2"	1-1/4"	166.5	40	3.2	200
HT,HH-1722	2200	1850	160	1650	270	145	32	115	125	32	12	2	1-1/4"	166.5	40	3.2	200

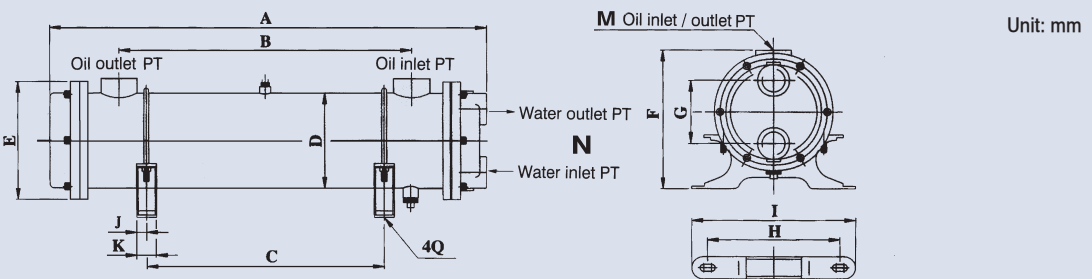

Model	A	B	C	D	E	F	G	H	I	J	K	M	N	Q
HTF,HHF-2208	950	640	ADJ.	219	265	323	137	290	360	38	50	2"~2-1/2"	1-1/2"~2"	5/8"
HTF,HHF-2212	1370	1060	ADJ.	219	265	323	-	-	-	-	-	2"~2-1/2"	1-1/2"~2"	5/8"
HTF,HHF-2216	1780	1490	ADJ.	219	265	323	-	-	-	-	-	2"~2-1/2"	1-1/2"~2"	5/8"
HTF,HHF-2222	2210	1860	ADJ.	219	265	323	-	-	-	-	-	2"~2-1/2"	1-1/2"~2"	5/8"
HTF,HHF-2508	980	640	ADJ.	270	325	385	160	345	405	38	50	2"~3"	2"	5/8"
HTF,HHF-2512	1400	1060	ADJ.	270	325	385	160	345	-	-	-	2"~3"	2"	5/8"
HTF,HHF-2516	1810	1470	ADJ.	270	325	385	160	345	-	-	-	2"~3"	2"	5/8"
HTF,HHF-2522	2240	1860	ADJ.	270	325	385	160	345	-	-	-	2"~3"	2"	5/8"

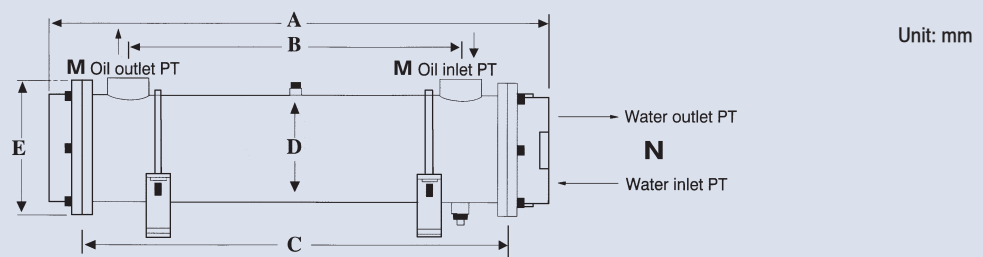

Model	A	B	C	D	E	M	N	Model	A	B	C	D	E	M	N
HTF-3208	975	635	810	12"	390	3"~4"	3"~4"	HTF-3508	975	635	810	14"	448	3"~4"	3"~4"
HTF-3212	1400	1060	1235	12"	390	3"~4"	3"~4"	HTF-3512	1400	1060	1235	14"	448	3"~4"	3"~4"
HTF-3216	1810	1470	1645	12"	390	3"~4"	3"~4"	HTF-3516	1810	1470	1645	14"	448	3"~4"	3"~4"
HTF-3222	2235	1895	2070	12"	390	3"~4"	3"~4"	HTF-3522	2235	1890	2070	14"	448	3"~4"	3"~4"

FIN TUBE TYPE OIL COOLER

Performance curves

Test conditions:

- 1. The flow rate of oil is twice as water
 - 2. The outlet temperature of oil: 50 °C
 - 3. The inlet temperature of water: 30 °C
 - 4. The viscosity of oil: ISO-68 (68CST)
- Pressure drop of oil:
 Δ : $\Delta P=0.5$ bar O: $\Delta P=1.0$ bar X: $\Delta P=1.5$ bar

HT-1405, HT-1408, HT-1412

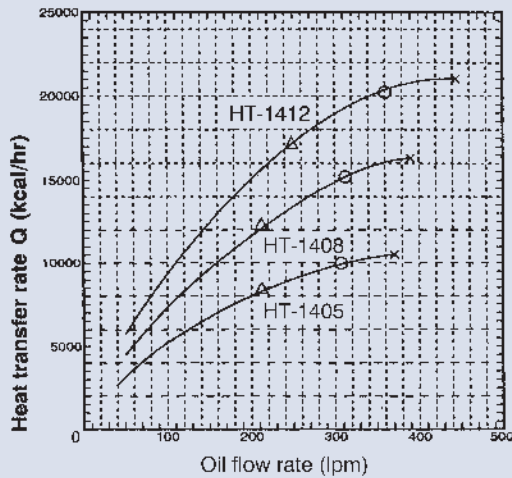

HT-1712, HT-1716

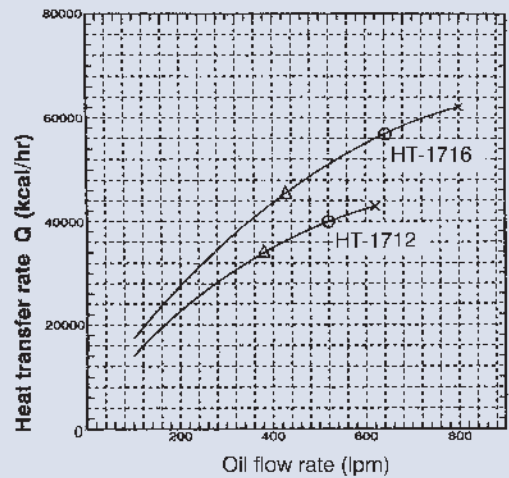

HTF-2208, HTF-2212, HTF-2216

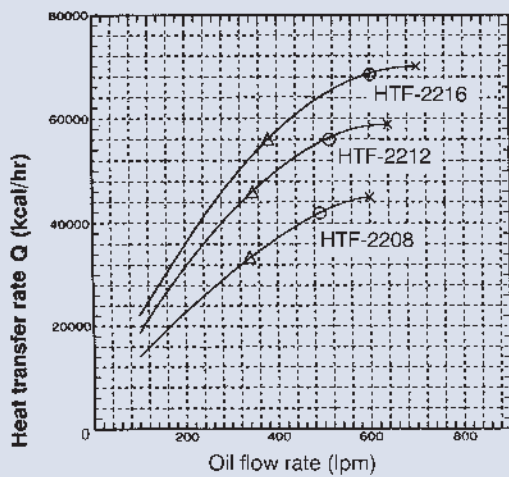

HTF-2512, HTF-2516, HTF-2522

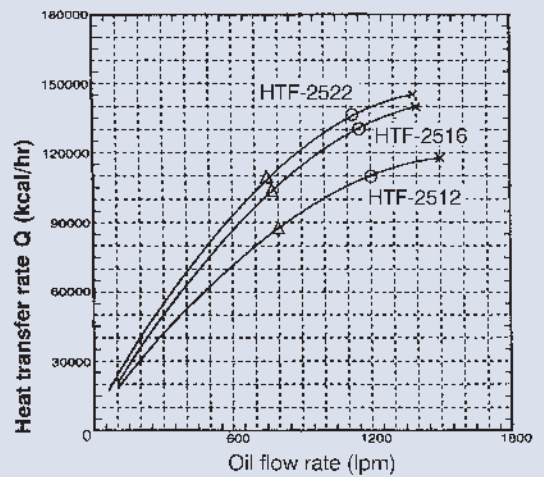

OIL TEMPERATURE CORRECTION

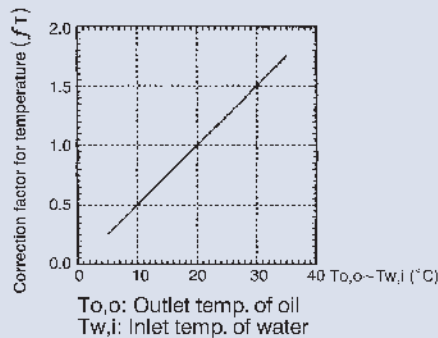

OIL VISCOSITY CORRECTION

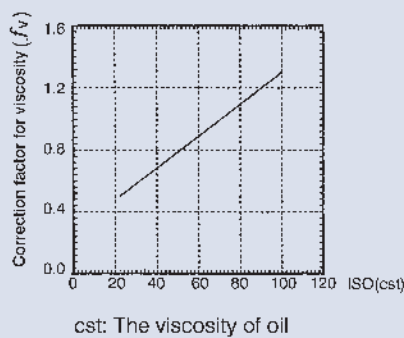

OIL FLOW CORRECTION

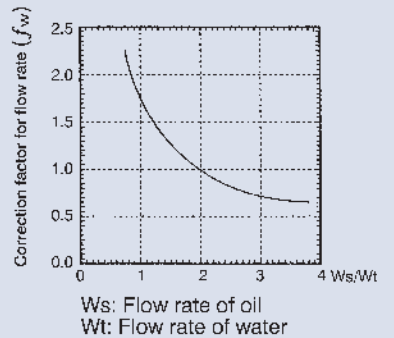

MULTI-TUBE TYPE OIL COOLER

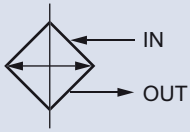

How to order

OR - 60

1	Model
2	Flow (lpm)

Specifications

Model	Heat Diffusion Area (m ²)	Nos. of Tube	Flow (lpm)	Weight (kg)	Model	Heat Diffusion Area (m ²)	Nos. of Tube	Flow (lpm)	Weight (kg)
OR-30	0.17	22	30	6.5	OR-800	2.9	58	800	48.6
OR-60	0.3	22	60	7.7	OR-1000	3.7	58	1000	57.4
OR-100	0.4	26	100	10.2	OR-1200	6.1	124	1200	103
OR-150	0.63	42	150	17.5	OR-1400	6.9	124	1400	111
OR-250	1.26	58	250	22.10	OR-1800	8.1	124	1800	118
OR-350	1.75	58	350	29.80	OR-2500	10.1	200	2500	160
OR-600	2	58	600	36.8	OR-3000	12.56	200	3000	200

Dimensions

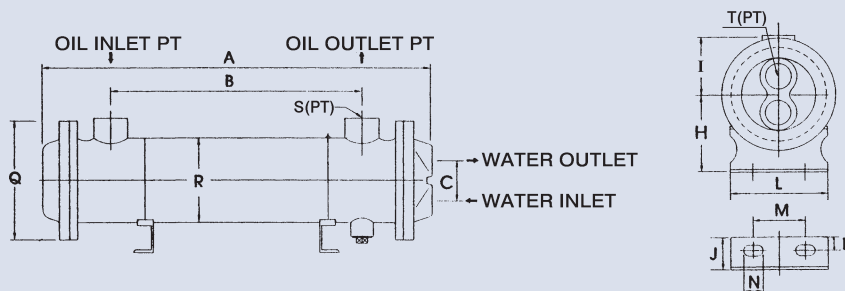

Unit: mm

Model	A	B	C	H	I	J	K	L	M	N	Q	R	S	T
OR-30	299	150	46	77	63	23	11	115.5	95	7x10	121	89.1	3/4"	3/4"
60	450	305												
100	555	403	76	95	70	33	12.5	145.5	106.5	10x20	134	101.6	3/4"	3/4"
150	575	385												
250	780	585												
350	1180	990	87	118	95	30	12.5	175	130	13x16	175	139.8	1-1/4"	1"
600	1175	950												
800	1700	1490												
1000	2135	1910												
1200	1690	1380	114	184	150	50	25	333	229	16x33	269	217	2-1/2"	2"
1400	1840	1530												
1800	2150	1840												
2500	1815	1435												
3000	2150	1800	154	218	178	50	25	352	247	16x33	302	273	3"	2"

THREADED-TUBE TYPE OIL COOLER

Dimensions

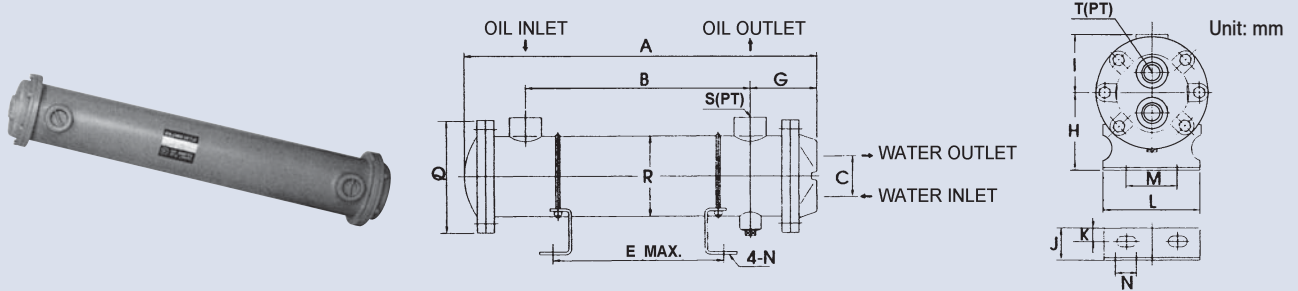

Model	A	B	C	E	G	H	I	J	K	L	M	N	Q	R	S	T	H.D.A m ²	Flow(lpm)	Weight(kg)
ST-303	300	150	46	100	90	77	63	23	11	115.5	95	7x10	121	89.1	3/4"	3/4"	0.3	50	6.5
304	390	225		175													0.4	60	7.5
305	450	305		235													0.5	70	9.0
307	600	440		380													0.7	110	10.5
309	755	584		525													0.9	130	12.0
311	900	728	675	1.1	150	13.5	1"	1"	1"	1"	1"	1"	1"	1"	1"	1"	1"	1"	
ST-408	470	284	215	0.8	130	14													
411	610	428	360	1.1	140	16													
415	765	572	500	1.5	150	18													
418	910	716	650	1.8	160	21													
421	1050	860	790	2.1	180	22	1-1/2"	1"	1"	1"	1"	1"	1"	1"	1"	1"	1"	1"	
ST-518	615	406	328	1.8	210	21													
522	770	558	480	2.2	260	26													
526	820	622	540	2.6	300	28													
530	915	702	620	3	330	30													
534	1075	838	760	3.4	370	33	1-1/2"	1"	1"	1"	1"	1"	1"	1"	1"	1"	1"	1"	
542	1255	1055	975	4.2	410	37													
ST-649	1090	836	735	4.9	600	47													
657	1275	1000	900	5.7	800	53													
668	1475	1218	1120	6.8	1000	60													
682	1745	1490	1390	8.2	1200	67	2"	1-1/4"	1"	1"	1"	1"	1"	1"	1"	1"	1"	1"	
ST-518	615	406	328	1.8	210	21													
522	770	558	480	2.2	260	26													
526	820	622	540	2.6	300	28													
530	915	702	620	3	330	30													
534	1075	838	760	3.4	370	33	1-1/2"	1"	1"	1"	1"	1"	1"	1"	1"	1"	1"	1"	
542	1255	1055	975	4.2	410	37													
ST-649	1090	836	735	4.9	600	47													
657	1275	1000	900	5.7	800	53													
668	1475	1218	1120	6.8	1000	60													
682	1745	1490	1390	8.2	1200	67	2"	1-1/4"	1"	1"	1"	1"	1"	1"	1"	1"	1"	1"	

Performance curves

Test condition:

1. The flow rate of water: 20 lpm
2. The inlet temperature of oil: 55 °C
3. The inlet temperature of water: 28 °C
4. The viscosity of oil: ISO-68 cst

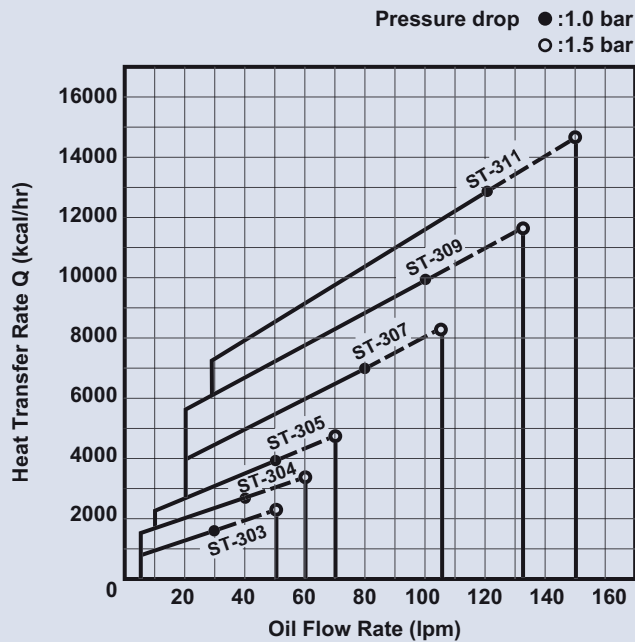

THREADED-TUBE TYPE OIL COOLER

Performance curves

Test condition:

1. The flow rate of water: 40 lpm
2. The inlet temperature of oil: 55 °C
3. The inlet temperature of water: 28 °C
4. The viscosity of oil: ISO-68 cst

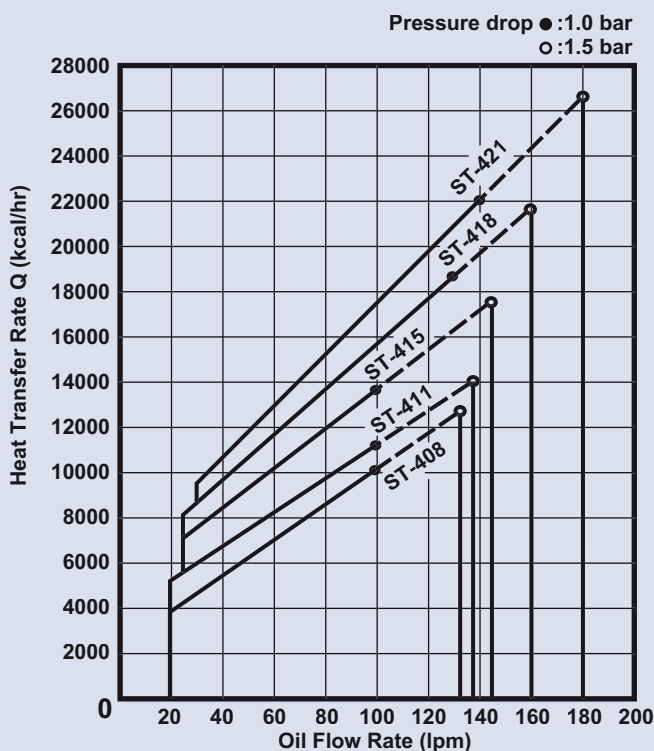

Test condition:

1. The flow rate of water: 50 lpm
2. The inlet temperature of oil: 55 °C
3. The inlet temperature of water: 28 °C
4. The viscosity of oil: ISO-68 cst

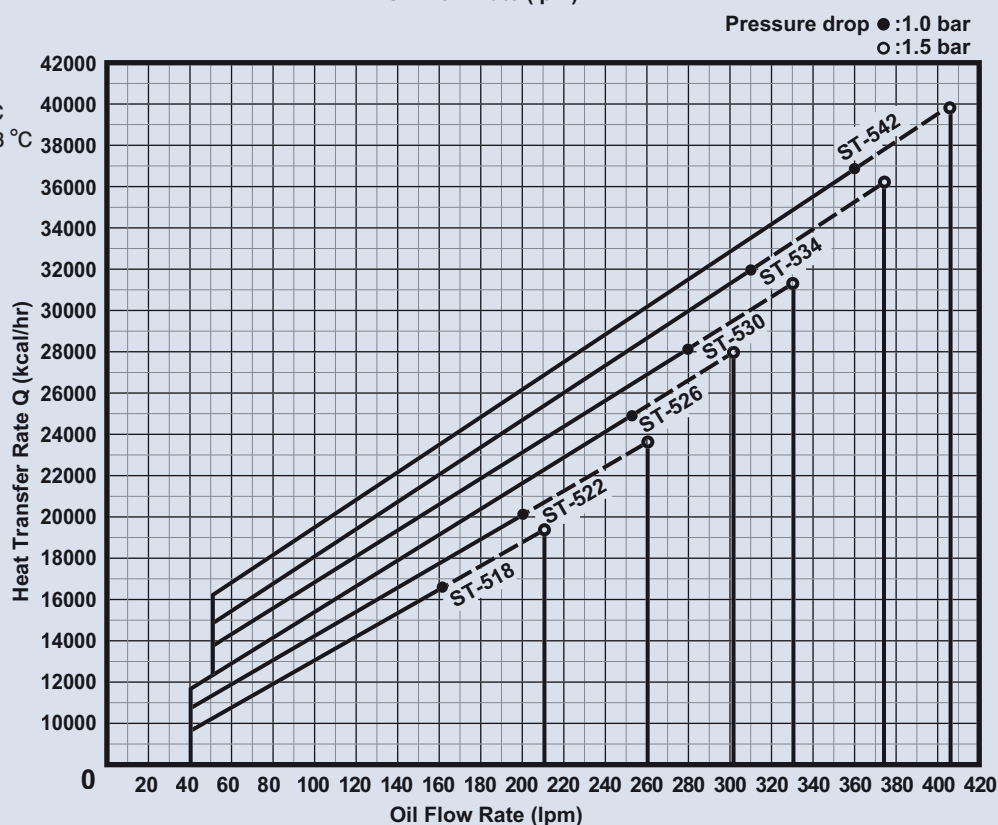

PLATE-FIN HEAT EXCHANGER

To avoid the leakage caused by peak pressure, an Anti-Burst Valve or By-Pass Valve should be always mounted. Off-Line cooling is strongly recommended. Pumping the oil from the tank to the heat exchanger with a separated cooling pump. Please refer to page 218.



How to order

AH0608T - C A(D) ✱

- 1 Model Fan dia: 6"x1 with temperature protection switch
- 2 With fan case
- 3 Voltage A1: AC115V A2: AC230V A3: AC380V D1: DC12V D2: DC24V

Specifications

Model	Port Size (PT)	Oil Flow (lpm)	Max. Pressure (bar)	Capacity kcal/h ($\Delta t=30\text{ }^{\circ}\text{C}$)	Hydraulic System (HP)	Weight (kg)			
	3/4"	3~60	20	1200	1~2	4.2			
AH0608T	Motor		Voltage (V)	Frequency (Hz)	Power (W)	Current (A)	Rated Speed (r.p.m)	Air Flow m^3/h	Noise dB (A)
	Phase	IP							
	Single	54	AC115	50/60	45/37	0.6/0.5	2850/3450	457/553	42/48
			AC230						
			AC380						
-	-	DC12	-	-	1.6	3350	500	51	
		DC24							

Dimensions

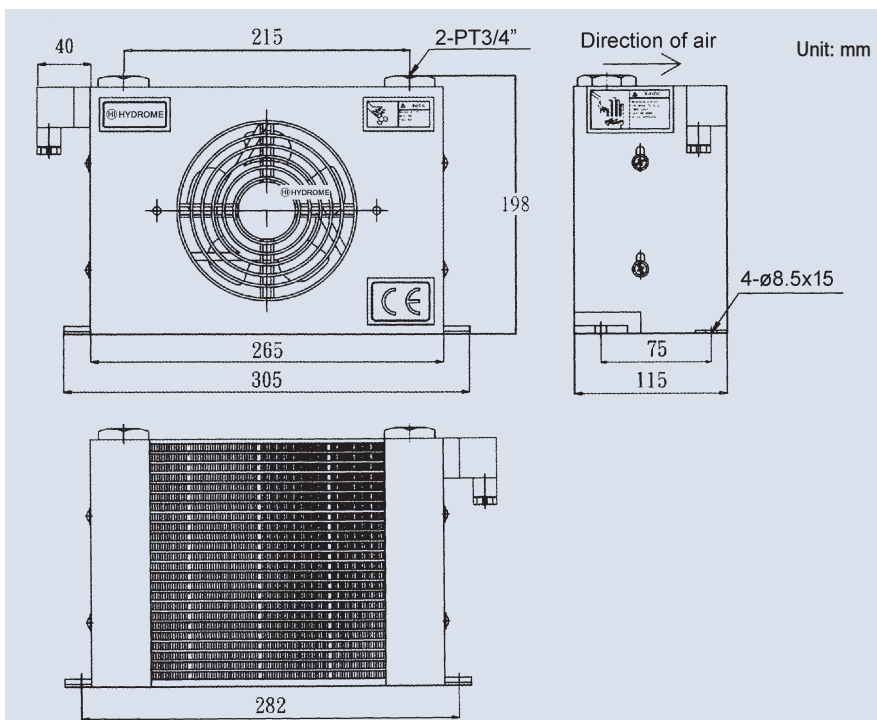

PERFORMANCE DIAGRAM

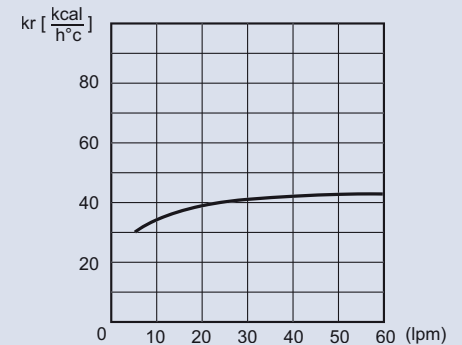

LOSS OF PRESSURE (at 32 Cst)

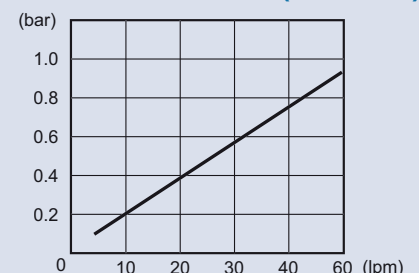

PLATE-FIN HEAT EXCHANGER

To avoid the leakage caused by peak pressure, an Anti-Burst Valve or By-Pass Valve should be always mounted. Off-Line cooling is strongly recommended. Pumping the oil from the tank to the heat exchanger with a separated cooling pump. Please refer to page 218.



How to order

AH0608LT - C A(D) ✱

- | | | |
|---|---------------|--|
| 1 | Model | Fan dia: 6"x2 with temperature protection switch |
| 2 | With fan case | |
| 3 | Voltage | A1: AC115V A2: AC230V A3: AC380V D1: DC12V D2: DC24V |

Specifications

Model	Port Size (PT)		Oil Flow (lpm)	Max. Pressure (bar)	Capacity kcal/h ($\Delta t=30^\circ\text{C}$)		Hydraulic System (HP)	Weight (kg)		
	AH0608LT	3/4"		3~60	20	2400		2~3	6	
Motor		Voltage (V)	Frequency (Hz)	Power (W)	Current (A)	Rated Speed (r.p.m)	Air Flow m^3/h	Noise dB (A)		
Phase								IP		
Single		54	AC115	50/60	90/74	1.2/1	2850/3450	914/1106	42/48	
			AC230		60/50				0.54/0.46	
-		-	AC380	-	-	3.2	3350	1000	51	
	DC12		-		0.32/0.28					
		DC24			1.6		840			

Dimensions

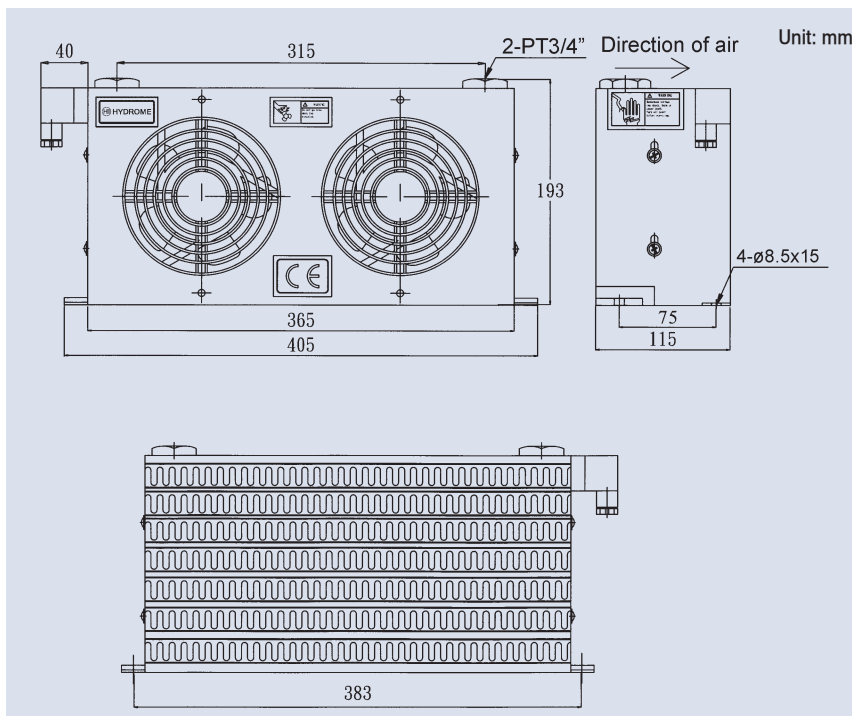

PERFORMANCE DIAGRAM

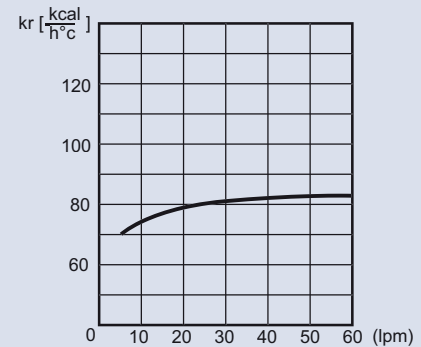

LOSS OF PRESSURE (at 32 Cst)

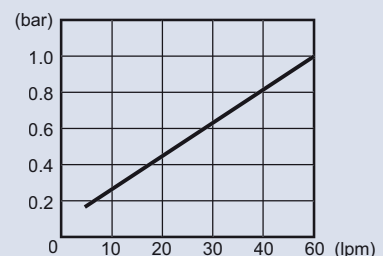

PLATE-FIN HEAT EXCHANGER

To avoid the leakage caused by peak pressure, an Anti-Burst Valve or By-Pass Valve should be always mounted. Off-Line cooling is strongly recommended. Pumping the oil from the tank to the heat exchanger with a separated cooling pump. Please refer to page 218.

The motor of DC fan is carbon brush type, which means the life-span was limited 2000 hours of service.



How to order

AH1012 - (3P) - C A(D) ✱

- | | | |
|---|---------------------------------------|---|
| 1 | Model | Fan dia: 10"x1 |
| 2 | 3P: 3 Phase double voltage 230 (400V) | |
| 3 | With fan case | |
| 4 | Voltage | A1: AC115V A2: AC230V D1: DC12V D2: DC24V |

Specifications

Model	Port Size (PT)	Oil Flow (lpm)	Max. Pressure (bar)	Capacity kcal/h ($\Delta t=30\text{ }^{\circ}\text{C}$)	Hydraulic System (HP)	Weight (kg)
AH1012/AH1012-3P	1"	20~100	20	5000/5200	3~5	10

Model	Motor		Voltage (V)	Frequency (Hz)	Power (W)	Current (A)	Rated Speed (r.p.m)	Air Flow m ³ /h	Noise dB (A)
	Phase	IP							
AH1012	Single	54	AC115	50/60	60/58	0.8/0.74	1300/1550	1500	55
			AC230			0.42/0.36			
	-	-	DC12	-	192	16	2000		60
			DC24			8	2400		
AH1012-3P	3	54	AC230	50/60	88/80	0.45/0.36	1430/1670		
			AC400			0.22/0.2			

Dimensions

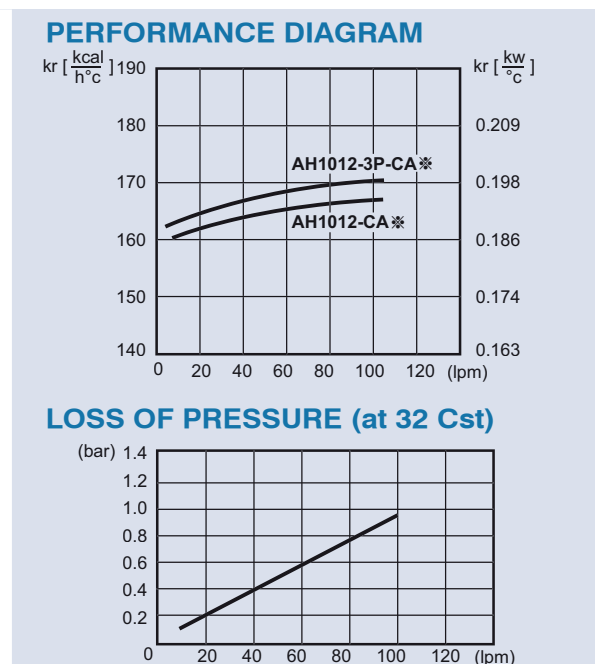
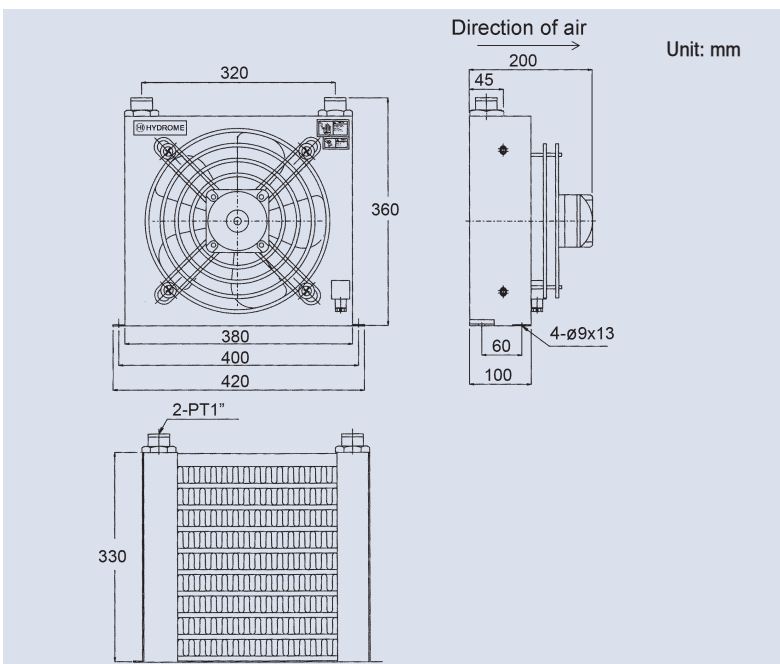
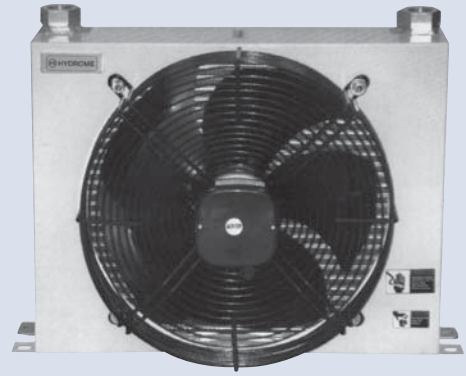

PLATE-FIN HEAT EXCHANGER

To avoid the leakage caused by peak pressure, an Anti-Burst Valve or By-Pass Valve should be always mounted. Off-Line cooling is strongly recommended. Pumping the oil from the tank to the heat exchanger with a separated cooling pump. Please refer to page 218.

The motor of DC fan is carbon brush type, which means the life-span was limited 2000 hours of service.



How to order

AH1215 - C A(D) ✱

	1	2	3
1	Model	Fan dia: 12"x1	
2	With fan case		
3	Voltage	A2: 230 (400V)	D1: DC12V D2: DC24V

Specifications

Model	Port Size (PT)		Oil Flow (lpm)	Max. Pressure (bar)	Capacity kcal/h ($\Delta t=30\text{ }^{\circ}\text{C}$)		Hydraulic System (HP)	Weight (kg)	
	AH1215	1"		20~100	20	7200		5~7.5	15
Motor		Voltage (V)	Frequency (Hz)	Power (W)	Current (A)	Rated Speed (r.p.m)	Air Flow m^3/h	Noise dB (A)	
Phase									IP
3		54	AC230	50/60	130	0.45/0.5	2420/2510	1800/1900	60
			AC400						
-	-	DC12	-	192	16	2000	2000	65	
		DC24							

Dimensions

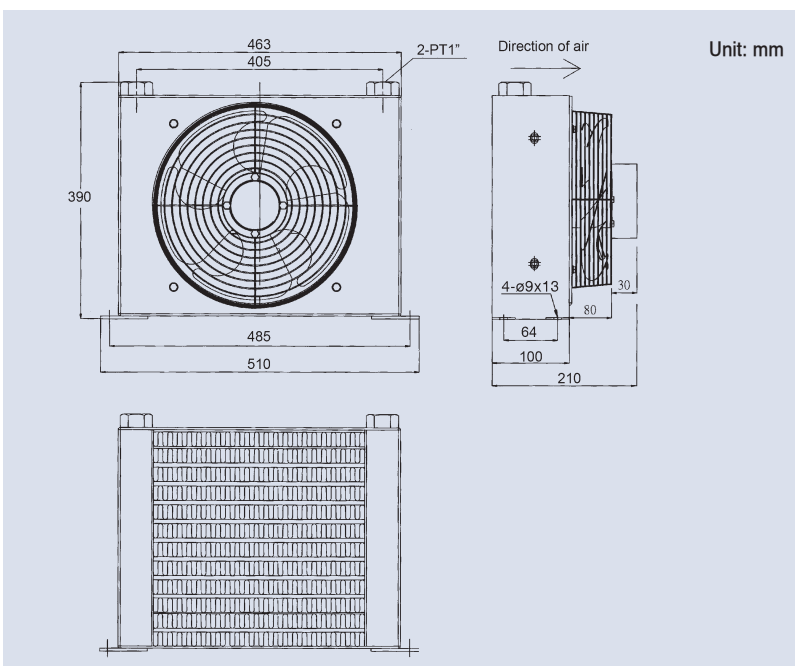

PERFORMANCE DIAGRAM

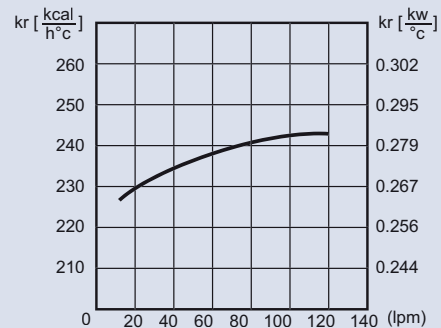

LOSS OF PRESSURE (at 32 Cst)

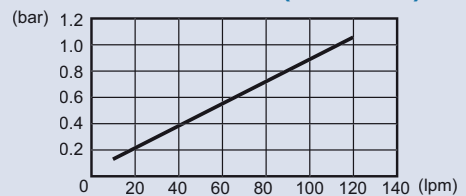
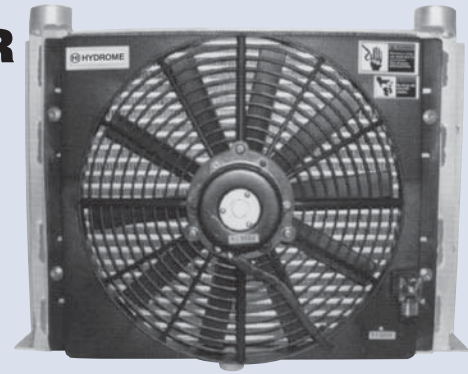

PLATE-FIN HEAT EXCHANGER

To avoid the leakage caused by peak pressure, an Anti-Burst Valve or By-Pass Valve should be always mounted. Off-Line cooling is strongly recommended. Pumping the oil from the tank to the heat exchanger with a separated cooling pump. Please refer to page 218.

The motor of DC fan is carbon brush type, which means the life-span was limited 2000 hours of service.



How to order

AH14 17, AH14 70 - A(D) ✱

1	Model	Fan dia: 14"x1
2	Size of A	17: 45mm 70: 70mm
3	Voltage	A1: AC115V A2: AC230V D1: DC12V D2: DC24V

Specifications

Model	Port Size (PT)	Oil Flow (lpm)	Max. Pressure (bar)	Capacity kcal/h ($\Delta t=30\text{ }^{\circ}\text{C}$)	Hydraulic System (HP)	Weight (kg)
AH1417/AH1470	See B	30~100	20	10000/11300	7.5~10/10~15	11/17

Model	Motor		Voltage (V)	Frequency (Hz)	Power (W)	Current (A)	Rated Speed (r.p.m)	Air Flow m ³ /h	Noise dB (A)
	Phase	IP							
AH1417	Single	54	AC115	50/60	40/50	0.46/0.35	1450/1650	2300/2760	60
			AC230			0.23/0.18			
AH1470	-	-	DC12	-	90	7.5	2000	2800	
			DC24		108	4.5	2200		

Dimensions

Unit: mm

Model	A	B	C	D
AH1417-A	45	2-PT1"	196	48
AH1470-A	70	2-PT1-1/4"	212	50

PERFORMANCE DIAGRAM



LOSS OF PRESSURE (at 32 Cst)

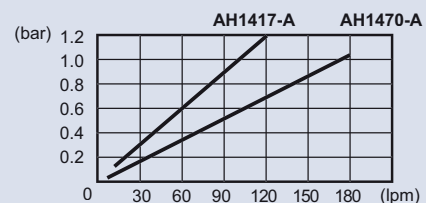
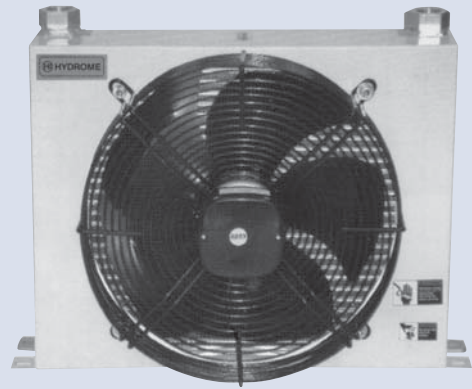

PLATE-FIN HEAT EXCHANGER

To avoid the leakage caused by peak pressure, an Anti-Burst Valve or By-Pass Valve should be always mounted. Off-Line cooling is strongly recommended. Pumping the oil from the tank to the heat exchanger with a separated cooling pump. Please refer to page 218.



How to order

AH1418 - C A※

1 2 3

- 1 Model Fan dia: 14"x1
- 2 With fan case
- 3 Voltage A2: AC230 / 400V A4: AC440V

Specifications

Model	Port Size (PT)		Oil Flow (lpm)	Max. Pressure (bar)	Capacity kcal/h ($\Delta t=30\text{ }^{\circ}\text{C}$)		Hydraulic System (HP)	Weight (kg)	
	AH1418	1"		30~100	20	10000		7.5~10	17
Motor		Voltage (V)	Frequency (Hz)	Power (W)	Current (A)	Rated Speed (r.p.m)	Air Flow m^3/h	Noise dB (A)	
Phase									IP
3		54	AC230	50/60	150/180	0.8/0.7	1380/1550	3200/3800	62
		AC400	150/180		0.4/0.36				
		AC440	200/260		0.4/0.43				

Dimensions

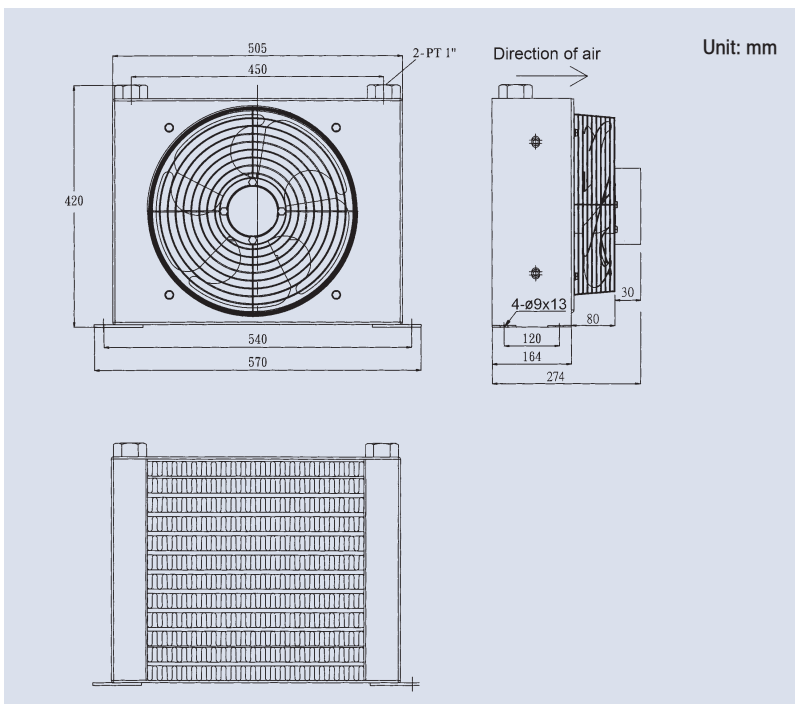

PERFORMANCE DIAGRAM

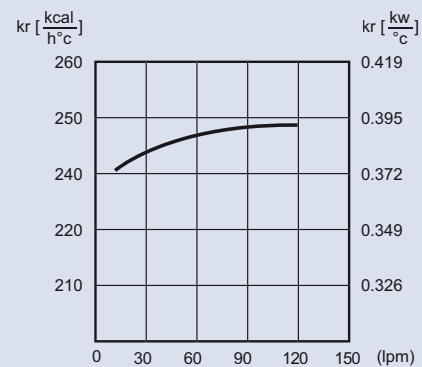

LOSS OF PRESSURE (at 32 Cst)

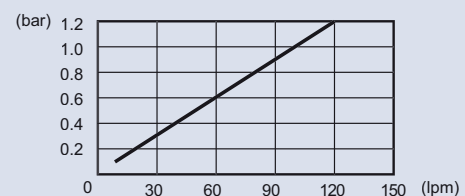
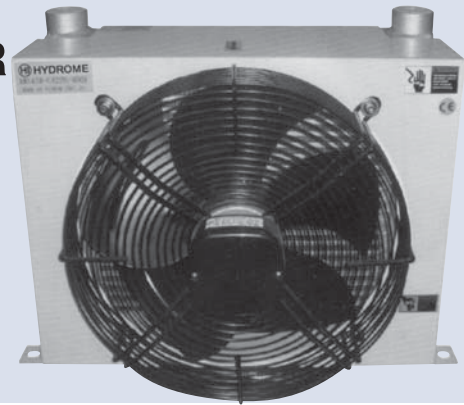

PLATE-FIN HEAT EXCHANGER

To avoid the leakage caused by peak pressure, an Anti-Burst Valve or By-Pass Valve should be always mounted. Off-Line cooling is strongly recommended. Pumping the oil from the tank to the heat exchanger with a separated cooling pump. Please refer to page 218.



How to order

AH1428 - C A✱

- 1 Model Fan dia: 14"x1
- 2 With fan case
- 3 Voltage A2: AC230 / 400V A4: AC440V

Specifications

Model	Port Size (PT)		Oil Flow (lpm)	Max. Pressure (bar)	Capacity kcal/h ($\Delta t=30\text{ }^\circ\text{C}$)		Hydraulic System (HP)	Weight (kg)	
	AH1428	1-1/4"		30~200	20	13000		15~20	21
Motor		Voltage (V)	Frequency (Hz)	Power (W)	Current (A)	Rated Speed (r.p.m)	Air Flow m ³ /h	Noise dB (A)	
Phase									IP
3		54	AC230	50/60	150/180	0.8/0.7	1380/1550	3200/3800	62
		AC400	150/180						
		AC440	200/260						

Dimensions

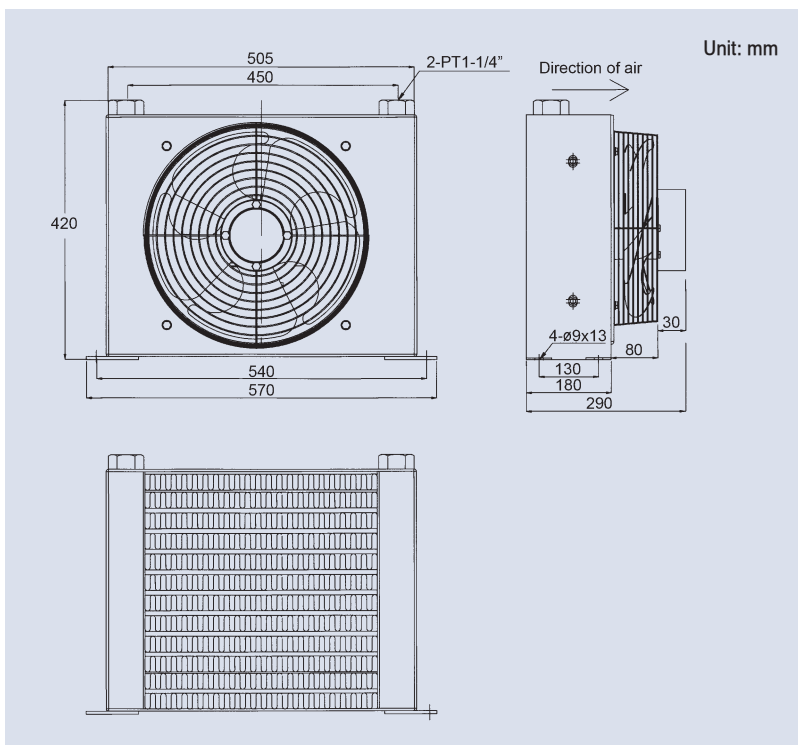

PERFORMANCE DIAGRAM

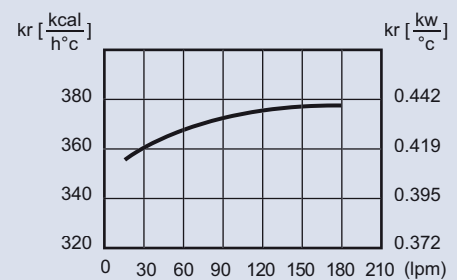

LOSS OF PRESSURE (at 32 Cst)

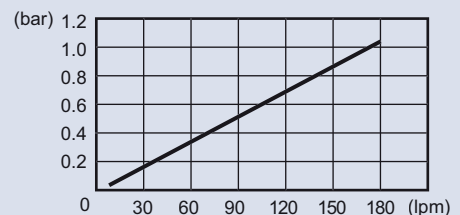

PLATE-FIN HEAT EXCHANGER

To avoid the leakage caused by peak pressure, an Anti-Burst Valve or By-Pass Valve should be always mounted. Off-Line cooling is strongly recommended. Pumping the oil from the tank to the heat exchanger with a separated cooling pump. Please refer to page 218.

The motor of DC fan is carbon brush type, which means the life-span was limited 2000 hours of service.



How to order

AH1490 - C A(D) ✱

	1	2	3
1	Model	Fan dia: 14"x1	
2	With fan case		
3	Voltage	A2: AC230 / 400V A4: AC440V	D1: DC12V D2: DC24V

Specifications

Model	Port Size (PT)	Oil Flow (lpm)	Max. Pressure (bar)	Capacity kcal/h ($\Delta t=30\text{ }^\circ\text{C}$)	Hydraulic System (HP)	Weight (kg)		
AH1490	1-1/2"	30~200	20	18000	20~25	30		
	Motor	Voltage (V)	Frequency (Hz)	Power (W)	Current (A)	Rated Speed (r.p.m)	Air Flow m^3/h	Noise dB (A)
	Phase	IP	50/60	150/180	0.8/0.7	1380/1550	3200/3800	62
	3	54		AC230	0.4/0.36			
AC400				0.4/0.43				
		AC440	200/260					

Dimensions

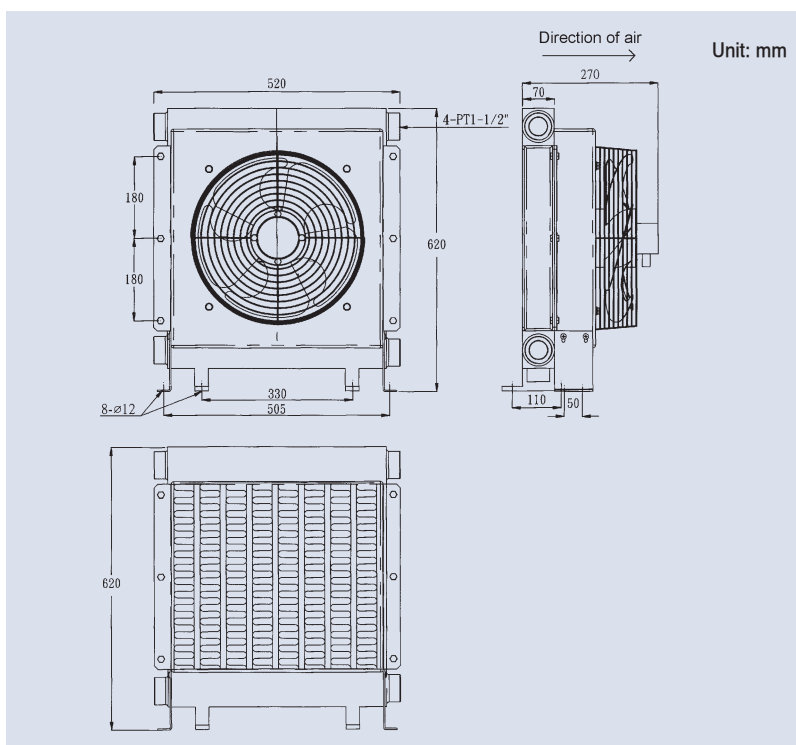

PERFORMANCE DIAGRAM

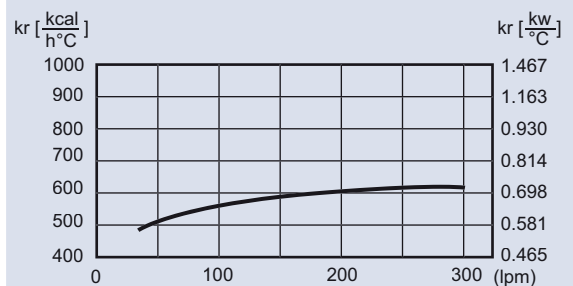

LOSS OF PRESSURE (at 32 Cst)

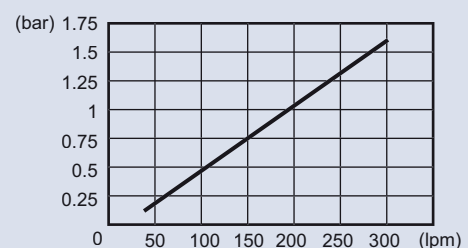
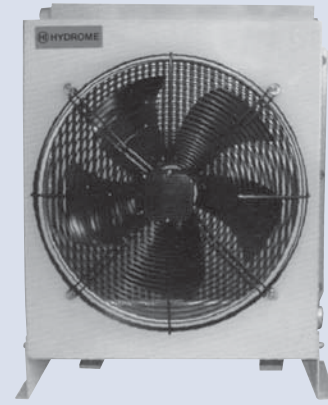

PLATE-FIN HEAT EXCHANGER

To avoid the leakage caused by peak pressure, an Anti-Burst Valve or By-Pass Valve should be always mounted. Off-Line cooling is strongly recommended. Pumping the oil from the tank to the heat exchanger with a separated cooling pump. Please refer to page 218.

The motor of DC fan is carbon brush type, which means the life-span was limited 2000 hours of service.



How to order

AH1680 - C A(D)※

- 1 Model Fan dia: 16"x1
- 2 With fan case
- 3 Voltage A2: AC230 / 400V A4: AC440V D1: DC12V D2: DC24V

Specifications

Model	Port Size (PT)	Oil Flow (lpm)	Max. Pressure (bar)	Capacity kcal/h ($\Delta t=30\text{ }^{\circ}\text{C}$)	Hydraulic System (HP)	Weight (kg)			
AH1680	1-1/2"	30~250	20	22000	25~40	35			
	Motor		Voltage (V)	Frequency (Hz)	Power (W)	Current (A)	Rated Speed (r.p.m)	Air Flow m ³ /h	Noise dB (A)
	Phase	IP	AC230 AC400 AC440	50/60	145/250	0.90/1.00	1380/1550	4000/4800	68
	3	54			145/250	0.50/0.52			
135/175					0.42/0.45				

Dimensions

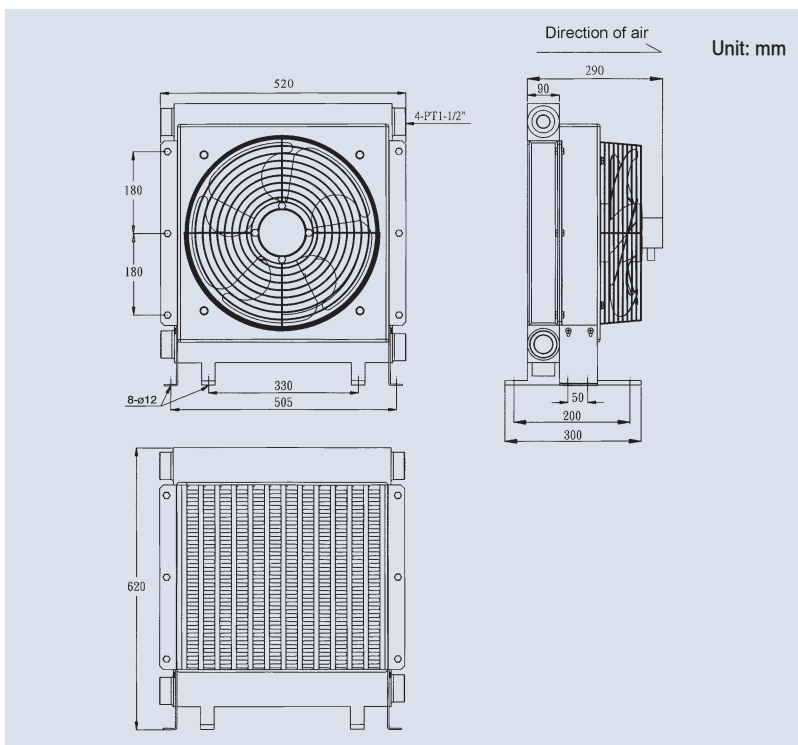

PERFORMANCE DIAGRAM

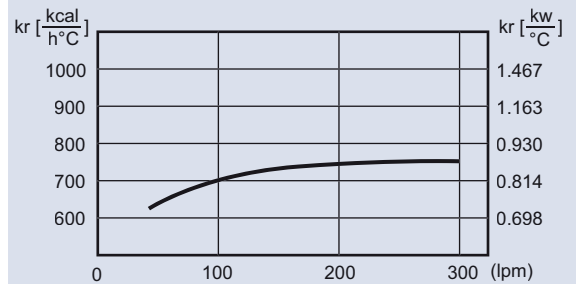

LOSS OF PRESSURE (at 32 Cst)

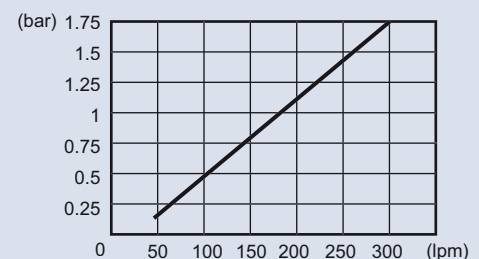

PLATE-FIN HEAT EXCHANGER

To avoid the leakage caused by peak pressure, an Anti-Burst Valve or By-Pass Valve should be always mounted. Off-Line cooling is strongly recommended. Pumping the oil from the tank to the heat exchanger with a separated cooling pump. Please refer to page 218.



How to order

AH1890 - C A*

	1	2	3
1	Model	Fan dia: 18"x1	
2	With fan case		
3	Voltage	A2: AC230 / 400V	A4: AC440V

Specifications

Model	Port Size (PT)	Oil Flow (lpm)	Max. Pressure (bar)	Capacity kcal/h ($\Delta t=30\text{ }^{\circ}\text{C}$)	Hydraulic System (HP)	Weight (kg)		
AH1890	1-1/2"	30~250	20	26000	30~50	52		
	Motor	Voltage (V)	Frequency (Hz)	Power (W)	Current (A)	Rated Speed (r.p.m)	Air Flow m^3/h	Noise dB (A)
	Phase	IP	50/60	250/350	1.10/1.20	1380/1550	5200/6200	72
	3	54		AC230	0.65/0.70			
AC400				0.45/0.51				
		AC440	210/300					

Dimensions

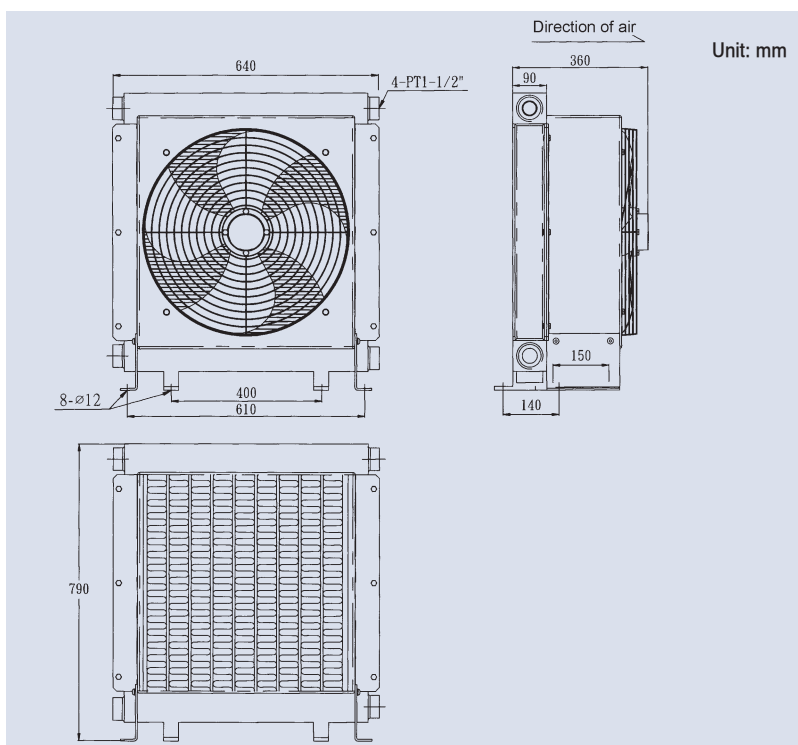

PERFORMANCE DIAGRAM

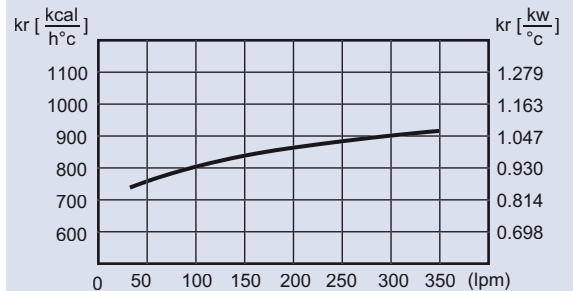

LOSS OF PRESSURE (at 32 Cst)

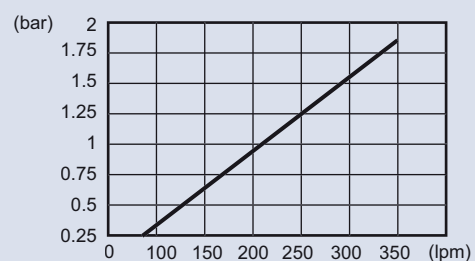

PLATE-FIN HEAT EXCHANGER

To avoid the leakage caused by peak pressure, an Anti-Burst Valve or By-Pass Valve should be always mounted. Off-Line cooling is strongly recommended. Pumping the oil from the tank to the heat exchanger with a separated cooling pump. Please refer to page 218.



How to order

AH2342 - C A✳

- | | | |
|---|---------------|---|
| 1 | Model | Fan dia: 23"x1 |
| 2 | With fan case | |
| 3 | Voltage | AC210~230 / 360~400 (50Hz) AC240~270 / 420~460 (60Hz) |

Specifications

Model	Port Size (PT)	Oil Flow (lpm)	Max. Pressure (bar)	Capacity kcal/h ($\Delta t=30\text{ }^{\circ}\text{C}$)	Hydraulic System (HP)	Weight (kg)			
AH2342	1-1/2"	50~250	20	37000	50~75	80			
	Motor		Voltage (V)	Frequency (Hz)	Power (W)	Current (A)	Rated Speed (r.p.m)	Air Flow m ³ /h	Noise dB (A)
	Phase	IP	AC210~230 / 360~400	50	1500	6.2~6.3 / 2.6~3.8	1400	7600	90
	3	55	AC240~270 / 420~460	60	17500	6.2~6.3 / 2.6~3.8	1680	9120	

Dimensions

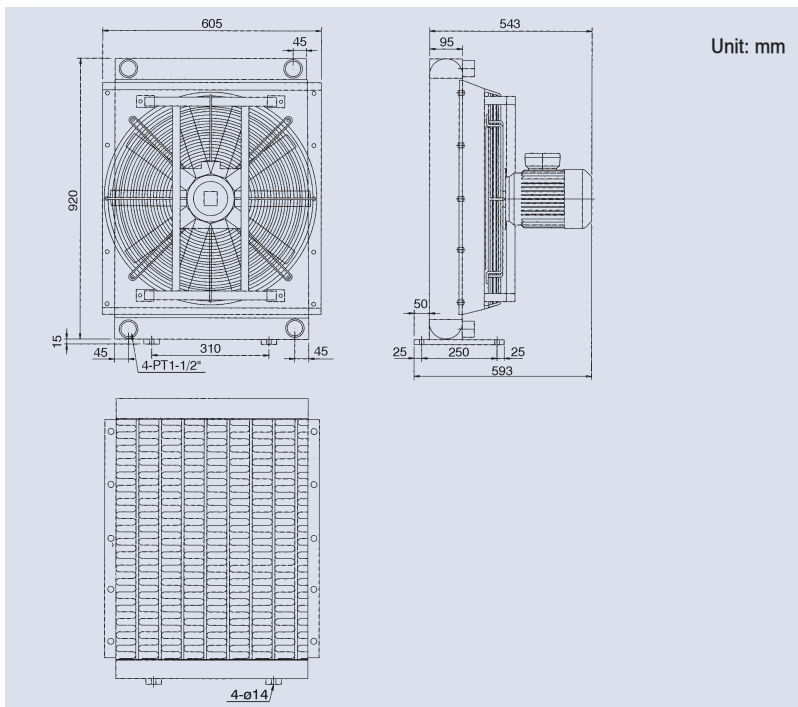

PERFORMANCE DIAGRAM

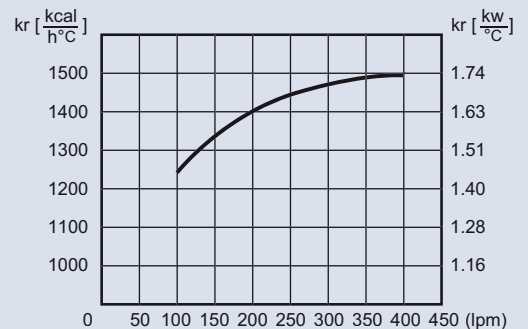

LOSS OF PRESSURE (at 32 Cst)

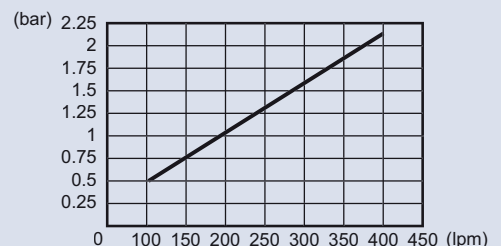
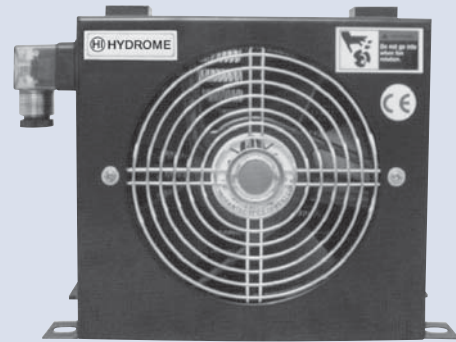

PLATE-FIN HEAT EXCHANGER

Suitable for the drain port in high-pressure variable piston pump and vane pump. Or off-line circuit.



How to order

AW0607 - C A(D)※

	1	2	3
1	Model	Fan dia: 6"x1 with temperature protection switch	
2	With fan case		
3	Voltage	A1: AC115V A2: AC230V A3: AC380V	D1: DC12V D2: DC24V

Specifications

Model	Port Size (PT)		Oil Flow (lpm)	Max. Pressure (bar)	Capacity kcal/h ($\Delta t=30\text{ }^{\circ}\text{C}$)		Weight (kg)		
		1/2"		1~20	15	800		3.3	
AW0607	Motor		Voltage (V)	Frequency (Hz)	Power (W)	Current (A)	Rated Speed (r.p.m)	Air Flow m^3/h	Noise dB (A)
	Phase	IP							
	Single	54	AC115	50/60	45/37	0.6/0.5	2850/3450	457/553	42/48
			AC230						
			AC380						
-	-	DC12	-	19.2	1.6	3350	500	51	
		DC24			0.8	420	420		

Dimensions

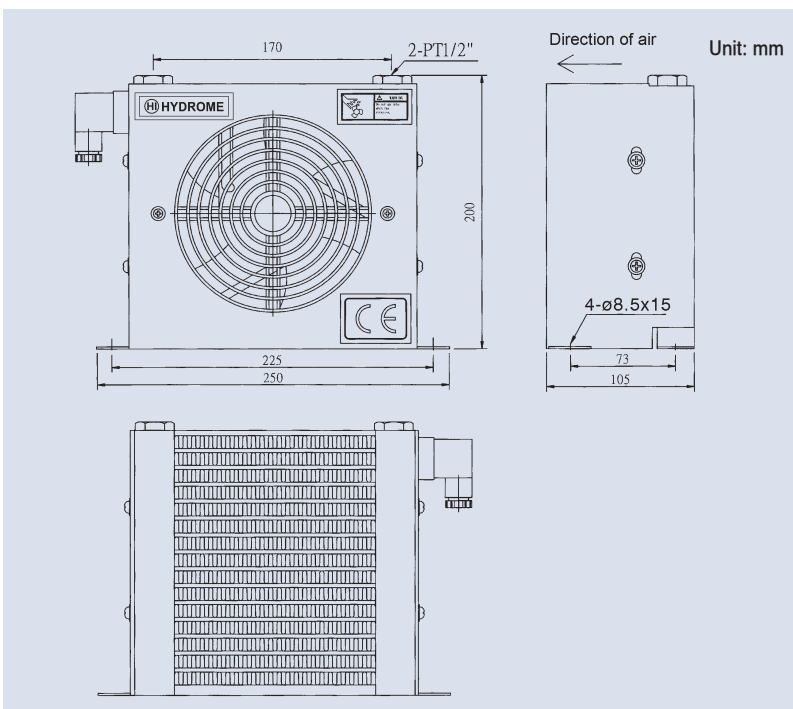

PERFORMANCE DIAGRAM

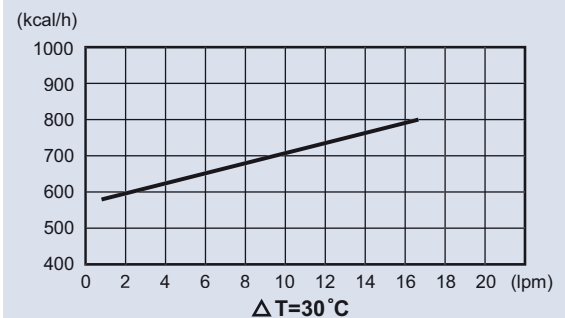

LOSS OF PRESSURE (at 32 Cst)

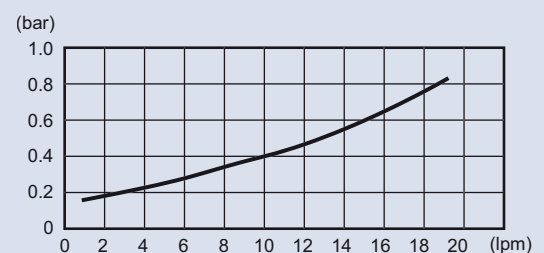
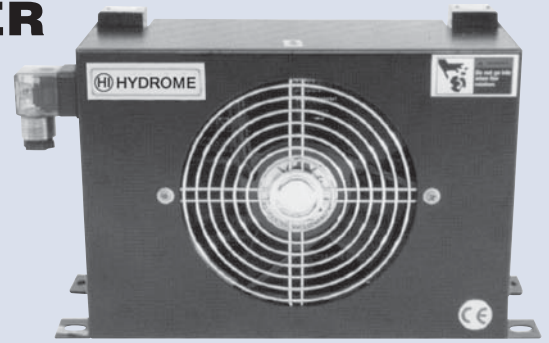

PLATE-FIN HEAT EXCHANGER

Suitable for the drain port in high-pressure variable piston pump and vane pump. Or off-line circuit.



How to order

AW0608 - C A(D) ✱

- | | | |
|---|---------------|--|
| 1 | Model | Fan dia: 6"x1 with temperature protection switch |
| 2 | With fan case | |
| 3 | Voltage | A1: AC115V A2: AC230V A3: AC380V D1: DC12V D2: DC24V |

Specifications

Model	Port Size (PT)		Oil Flow (lpm)	Max. Pressure (bar)		Capacity kcal/h ($\Delta t = 30^\circ\text{C}$)		Weight (kg)	
		1/2"		1~20	15		900		3.7
AW0608	Motor		Voltage (V)	Frequency (Hz)	Power (W)	Current (A)	Rated Speed (r.p.m)	Air Flow m^3/h	Noise dB (A)
	Phase	IP							
	Single	54	AC115	50/60	45/37	0.6/0.5	2850/3450	457/553	42/48
			AC230						
			AC380						
-	-	DC12	-	19.2	1.6	3350	500	51	
		DC24							
					0.8		420		

Dimensions

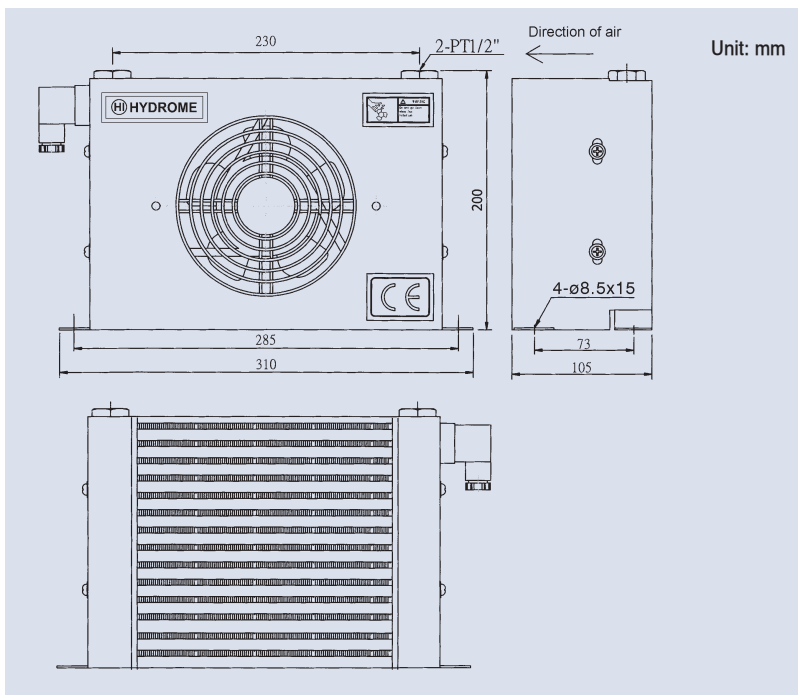

PERFORMANCE DIAGRAM

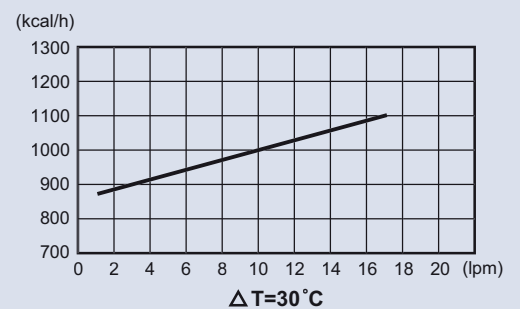

LOSS OF PRESSURE (at 32 Cst)

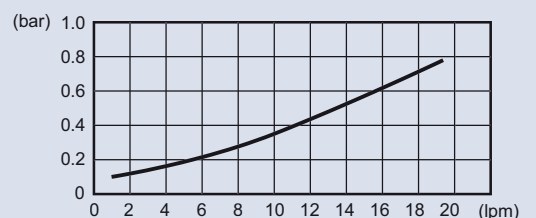

PLATE-FIN HEAT EXCHANGER

Suitable for the drain port in high-pressure variable piston pump and vane pump. Or off-line circuit.



How to order

AW0608L - C A(D) ✱

1 2 3

- 1 Model Fan dia: 6"x2 with temperature protection switch
- 2 With fan case
- 3 Voltage A1: AC115V A2: AC230V A3: AC380V D1: DC12V D2: DC24V

Specifications

Model	Port Size (PT)		Oil Flow (lpm)		Max. Pressure (bar)		Capacity kcal/h ($\Delta t=30\text{ }^{\circ}\text{C}$)		Weight (kg)		
		1/2"		1~20		15		1550		5.2	
AW0608L	Motor		Voltage (V)	Frequency (Hz)	Power (W)	Current (A)	Rated Speed (r.p.m)	Air Flow m^3/h	Noise dB (A)		
	Phase	IP									
	Single	54	AC115	50/60	90/74	1.2/1	2580/3450	914/1106	42/48		
			AC230								
			AC380								
-	-	DC12	-	38.4	3.2	3350	1000	51			
		DC24									
							840				

Dimensions

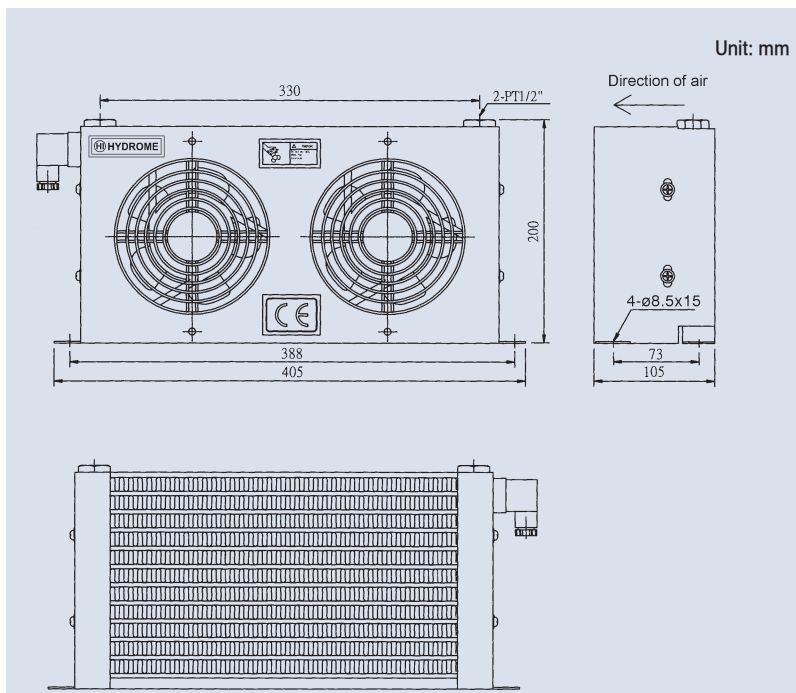

PERFORMANCE DIAGRAM

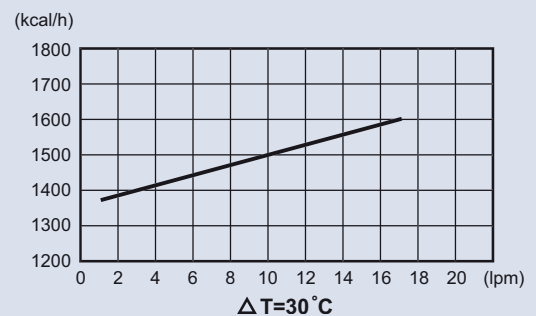

LOSS OF PRESSURE (at 32 Cst)

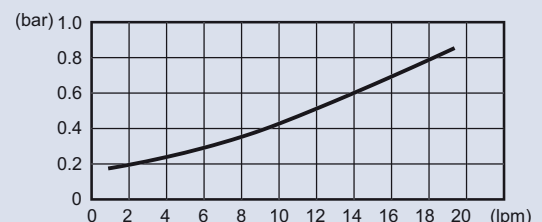
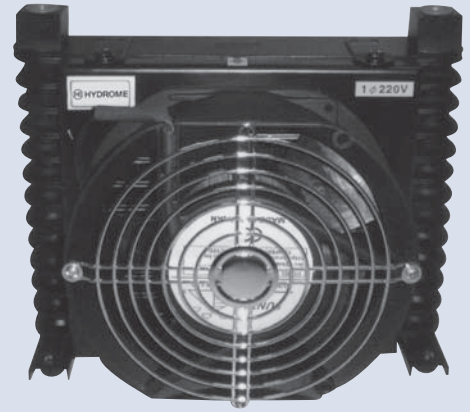

PLATE-FIN HEAT EXCHANGER

Only suitable for the drain port in variable vane pump which working pressure is under 70 bar. (drain only)



How to order

AL* - A(D)*

1	Model	Fan dia: 6"x1" with temperature protection switch	AL404 PT1/2"	AL608 PT3/8"	AL609 PT1/2"
2	Voltage	A1: AC115V A2: AC230V A3: AC380V	D1: DC12V	D2: DC24V	

Specifications

Model	Motor		Voltage (V)	Frequency (Hz)	Power (W)	Current (A)	Rated Speed (r.p.m)	Air Flow m³/h	Noise dB (A)	Oil Flow (lpm)	Max. Pressure (bar)	Capacity (kcal/h) Δt=30 °C	Weight (kg)
	Phase	IP											
AL404	Single	54	AC115	50/60	45/37	0.6/0.5	2850/3450	457/553	42/48	1~10	10	1100	2.25
AL608			AC230									0.27/0.23	950
AL609	-	-	AC380	-	30/25	0.16/0.14	3350	500	51	-	-	950	2
			DC12									1.6	420
			DC24		19.2	0.8							

Dimensions

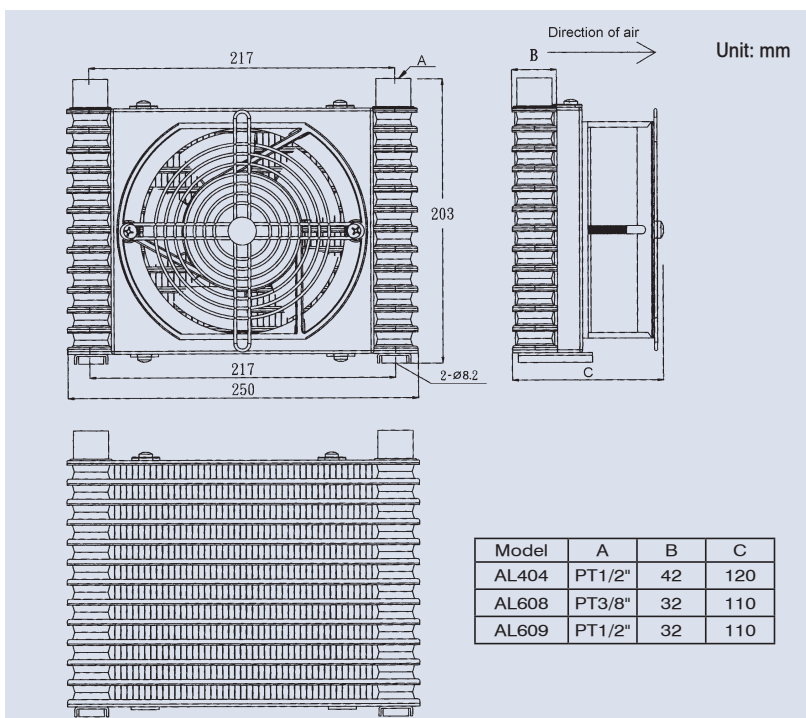

PERFORMANCE DIAGRAM

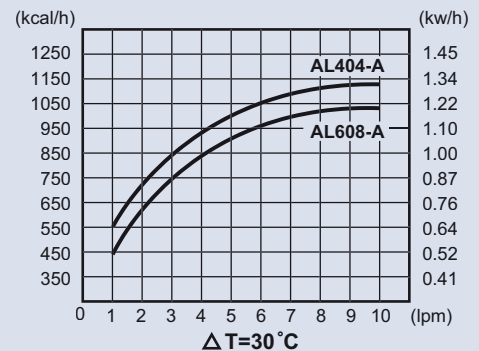

LOSS OF PRESSURE (at 32 Cst)

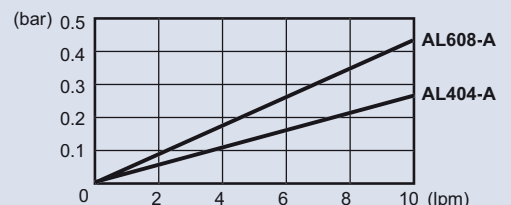

PLATE-FIN HEAT EXCHANGER

Only suitable for the drain port in variable vane pump which working pressure is under 70 bar. (drain only)



How to order

AL* - C A(D)*

	1	2	3			
1	Model	Fan dia: 6"x1"	with temperature protection switch	AL404 PT1/2"	AL608 PT3/8"	AL609 PT1/2"
2	With fan case					
3	Voltage	A1: AC115V	A2: AC230V	A3: AC380V	D1: DC12V	D2: DC24V

Specifications

Model	Motor		Voltage (V)	Frequency (Hz)	Power (W)	Current (A)	Rated Speed (r.p.m)	Air Flow m³/h	Noise dB (A)	Oil Flow (lpm)	Max. Pressure (bar)	Capacity (kcal/h) Δt=30 °C	Weight (kg)	
	Phase	IP												
AL404-C	Single	54	AC115	50/60	45/37	0.6/0.5	2850/3450	457/553	42/48	1~10	10	1200	2.6	
AL608-C			AC230									0.27/0.23	1050	2.25
			AC380									0.16/0.14	1050	2.25
AL609-C	-	-	DC12	-	19.2	1.6	3350	500	51			1050	2.25	
			DC24			0.8		420						

Dimensions

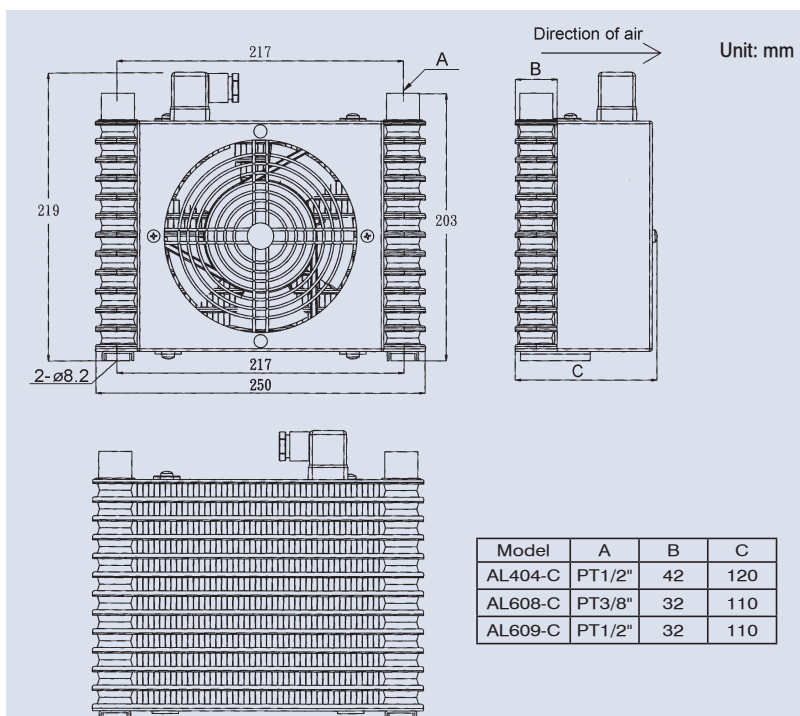

PERFORMANCE DIAGRAM

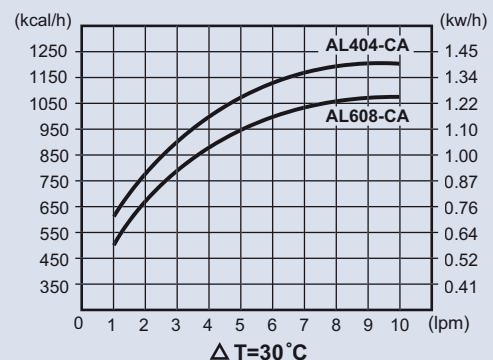

LOSS OF PRESSURE (at 32 Cst)

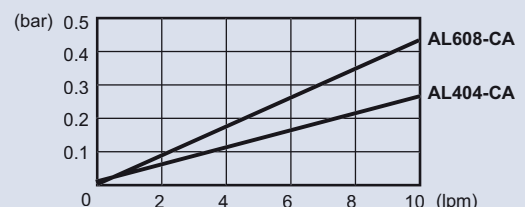

PLATE-FIN HEAT EXCHANGER

Only suitable for the drain port in variable vane pump which working pressure is under 70 bar. (drain only)



How to order

AL※ - 4 A※

	1	2	3			
1	Model	With temperature protection switch	AL404 PT1/2"	AL608 PT3/8"	AL609 PT1/2"	
2	Fan dia:	4: 4"				
3	Voltage	A1: AC115V	A2: AC230V			

Specifications

Model	Motor		Voltage (V)	Frequency (Hz)	Power (W)	Current (A)	Rated Speed (r.p.m)	Air Flow m ³ /h	Noise dB (A)	Oil Flow (lpm)	Max. Pressure (bar)	Capacity (kcal/h) Δt=30 °C	Weight (kg)
	Phase	IP											
AL404-4	Single	54	AC115	50/60	14/12	0.26/0.22 0.13/0.11	2600/2800	248/252	35	1~10	10	900	1.75
AL608-4			AC230									800	1.5
AL609-4	-	-	-	-	-	-	-	-	-	-	-	800	1.5

Dimensions

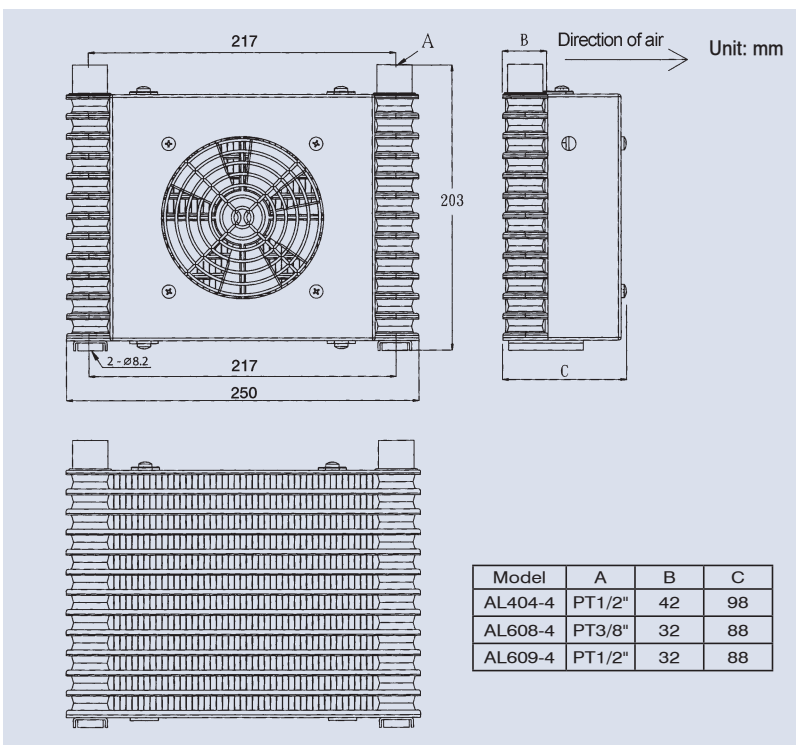

PERFORMANCE DIAGRAM

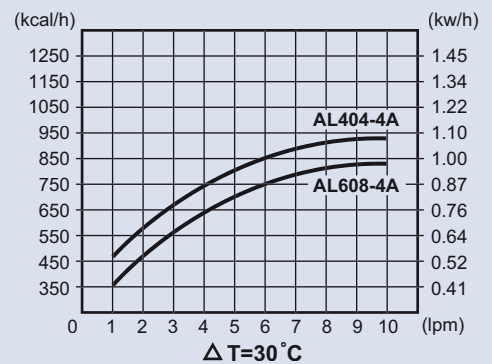

LOSS OF PRESSURE (at 32 Cst)

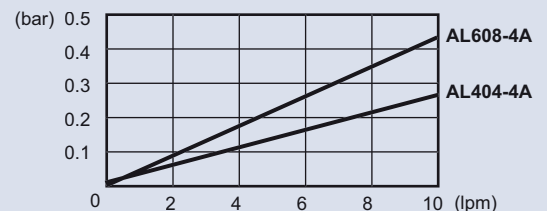

PLATE-FIN HEAT EXCHANGER

Only suitable for the drain port in variable vane pump which working pressure is under 70 bar. (drain only)



How to order

AL ✱
1 2

1	Model
2	404 PT1/2" 608 PT3/8" 609 PT 1/2"

Specifications

Model	Oil Flow (lpm)	Max. Pressure (bar)	Weight (kg)
AL404	1~10	10	1
AL608			0.75
AL609			0.75

Dimensions

Unit: mm

Model	A	B	C	D	E	F
AL404	PT1/2"	42	66	217	203	250
AL608	PT3/8"	32	56	217	203	250
AL609	PT1/2"	32	56	217	203	250

LOSS OF PRESSURE (at 32 Cst)

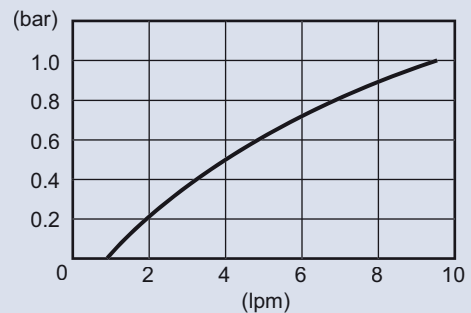

COOLING PUMP & ANTI-BURST VALVE

Dimensions

Cooling pump-for off-line circuit

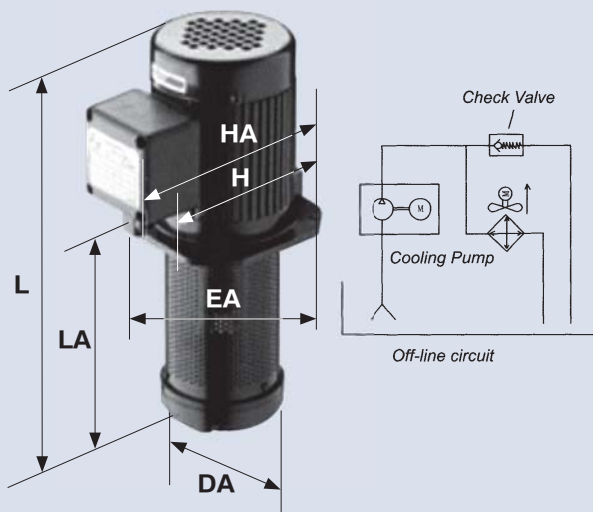

Model	Motor (HP)	Flow Rate (lpm)	L	LA	DA	H	HA	EA	Port (Rc/PT)
TC-6130	1/6	20	275	130	90	124	160	128	1/2"
TC-6180	1/6	20	325	180	90	124	160	128	1/2"
TC-4155	1/4	50	341	155	126	160	191	158	3/4"
TC-4220	1/4	50	406	220	126	160	191	158	3/4"
TC-4350	1/4	50	536	350	126	160	191	158	3/4"
TC-2180	1/2	80	385	180	126	170	196	171	1"
TC-2290	1/2	80	495	290	126	170	196	171	1"
TC-1180	1	120	400	180	151	180	191	185	1"
TC-1240	1	120	460	240	151	180	196	185	1"
TC-1380	1	120	600	380	151	180	196	185	1"

Anti-burst valve - effective for peak pressure

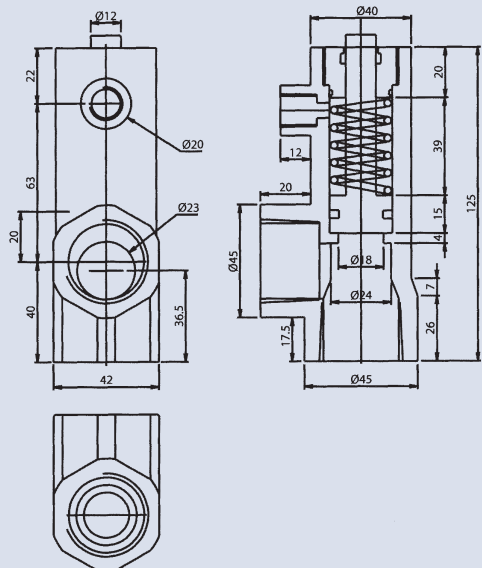
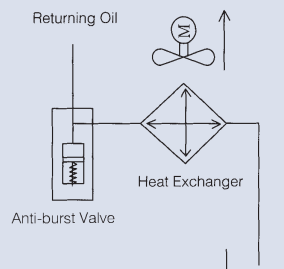

PLATE-FIN HEAT EXCHANGER

INSTALLATION & MAINTENANCE

AH cooler fittings

- Option 1. Off-line circuit is strongly recommended
- Option 2. Use patent product anti-burst Valve Fig.1 / Fig.2
- Option 3. By-pass with check valve (not recommend) Fig.3 / Fig.4

Special notes for option 3

1. The working pressure for AH series is 20 bar.
2. Be carefully the hammering and pulsations pressure which may cause irreversible damage to the cooler.
3. The spring of check valve may crack after a long period of working.

Piping caution

1. Outlet pipe's diameter must match with diameter of the port, and cannot be shrank.
2. Using straight joint or flexible pipe to reduce the feedback resistance.
3. More less of curve and curve angles should be better.

Conclusion: The feedback oil goes as smooth or fast as possible, to get a better heat rejection.

Installation

The cooler should be mounted at clean environment where is well ventilated area, keep fan diameter free from both cooling side and hot side.

Avoid locating the cooler at areas where can cause obstruction of air intake or exhaust vent.

Avoid locating the cooler at environment with atmosphere contacting corrosive or flammable dusts, oil mist, conductive power (such as carbon or metal).

If mounted in a closed area, sufficient ventilation must be provided. Heat transfer from the cooling system to ambient air may not increase room temperature, if these conditions are not met, air ducts have to be installed between cooling system and the outside to provide sufficient ventilation.

Check the supply voltage and frequency correspond to the rating plate.

Maintenance

Before maintenance, please make sure to keep the power off.

Ensure that there are no obstacles to the flow of air, either at the intake or at the outlet from the core, please maintain the cooler termly for a longer life.

External cleaning of air side

This can be done by either washing the cooler with a mild cleaner (compatible with aluminum), or with compressed air. A power spray washer works well. Care should be taken not to damage the fins. The direction of stream shall be parallel to the fins in order not to damage it. The cooler needs to be dried completely before restarting operation.

Internal cleaning of cooler side

The cooler should be disconnected, and a suitable cleaning agent used for removing the type of deposit, yet safe on aluminum should be circulated through the cooler until clean. After cleaning procedure, the cleaning medium shall be completely drained and blown out by means of compressed air.

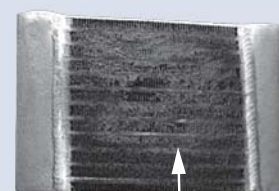
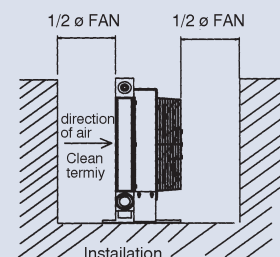
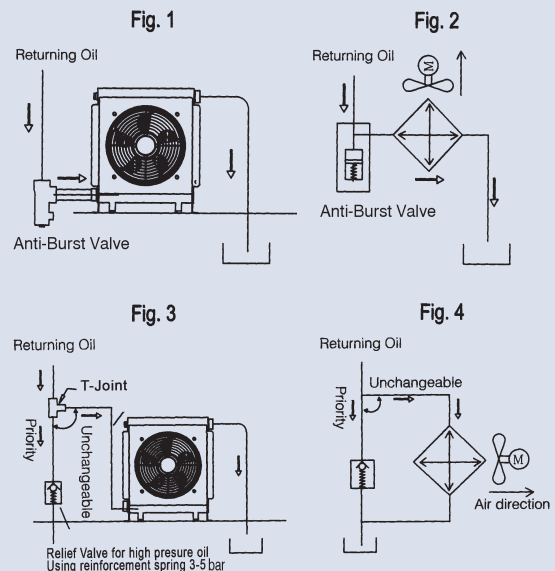

Dust on cooling air inlet side

PLATE-FIN HEAT EXCHANGER

CALCULATION OF AIR-OIL HEAT EXCHANGER INSTALLED ON HYDRAULIC SYSTEM

Introduction:

First of all, the choice of cooling system needs finding out the heat quantity of the hydraulic system, and furthermore we can design the appropriate cooling mode and ability for the requirements of clients.

The quantity of producing heat on hydraulic system can not be estimated by calculation, because of the different of components and elements, using frequency and the design of circuit make this impossible.

1. Choosing the cooler rely on flow rate is only a basic condition, because we choose the input motor horse power by considering the pressure of pump and flow rate in the meantime.
2. The selecting of cooler depended on the quantity of producing heat matches up with the cooling capability on the system.
3. According to the actuality experience, we could count up the appraised value by inputting 70% electricity energy into the heat quantity. (different engineer and elements make this different.)
4. If we are using more delicate components and less heat quantity product, then the 70% heat quantity could be lower to 60% or much lower. Please confirm to your distributor.
5. If there is hydraulic motor in the circuit, then we should calculate the heat quantity up to 100%.

Data required

1. Simplify

Contrast the input horse power with hydraulic horse power in the performance table, and you could find out the applicable cooler.

2. Calculate

N =installed power in the system (kW)

Q =heat to be dissipated (kcal/h)

T_o =maximum allowed oil temperature (°C)

T_{amb} =ambient temperature (°C)

K_r : Means the required specific performance of the heat exchanger

$K_r=Q/\Delta T$, ΔT is the difference between oil inlet temperature and summer ambient temperature, while Q is the quantity of heat to be dissipated which can be easily calculated considering 60~100% of installed power.

Example (hydraulic):

$N=20$ kW $T_o=50$ °C $T_{amb}=35$ °C

$Q=70\% \times 20$ kW=14 kW=12040 kcal/h (1kW=860 kcal/h)

$\Delta T=50-35=15$ °C

$K_r=12040$ kcal/h $\div 15$ °C=802 kcal/h °C=0.93 kW/°C

The choice of the correct cooler is made by using the diagrams.

You will find in our technical catalogues.

Equivalent among main units

1HP=635kcal/h 1kW=860kcal/h 1cSt=1 mm²/sec 1BTU=0.25 kcal/h 1bar=100kpa

PLATE-FIN HEAT EXCHANGER



How to order

3T
S1 - 20 - 4T 4(6) C A*(D*) P E

1	2	3	4	5	6	7	8
1	Series no.			5	None: Without fan case C: With fan case		
2	Model			6	Voltage D1: DC12V D2: DC24V A1: AC110V A2: AC220V A3: AC380V (50/60HZ)		
3	Port size 3T: PT 3/8" 4T: PT 1/2"			7	Motor phase P: Single phase		
4	Fan diameter 4: 4" 6: 6"			8	E: CE approved		

Specifications

Oil Flow (lpm)	Capacity $\Delta t=30\text{ }^{\circ}\text{C}$ (Kcal/hr)	MAX. Pressure (bar)	Voltage (V \pm 10%)	Frequency (Hz)	Current (A)	Power (Watt)	Rated Speed (r.p.m)	Air Flow (m ³ /hr)	Motor (IP)	Noise (dB (A))	Weight (kg)		
1~15	No fan	15	-	-	-	-	-	-	-	-	1.2		
	830 (4" fan)		DC12	-	0.6	7.2	2600	187	54	40	2.4		
			DC24	-	0.3	7.2	2600	187		40			
			110	50/60	0.24/0.27	19/23	2700/3100	142.8/178.5		45/51			
			220	50/60	0.12/0.14	20/24	2700/3100	142.8/178.5		45/51			
	950 (6" fan)		DC12	-	0.96	11.5	3000	384.2	54	51	2.8		
			DC24	-	0.48	11.5	3000	384.2		51			
			110	50/60	0.48/0.55	45/52	2800/3100	323/374		53/59			
			220	50/60	0.28/0.35	44/51	2800/3100	323/374		53/59			
					380	50/60	0.12/0.15	46/57	2800/3100	323/374		53/59	

Dimensions/Performance curves

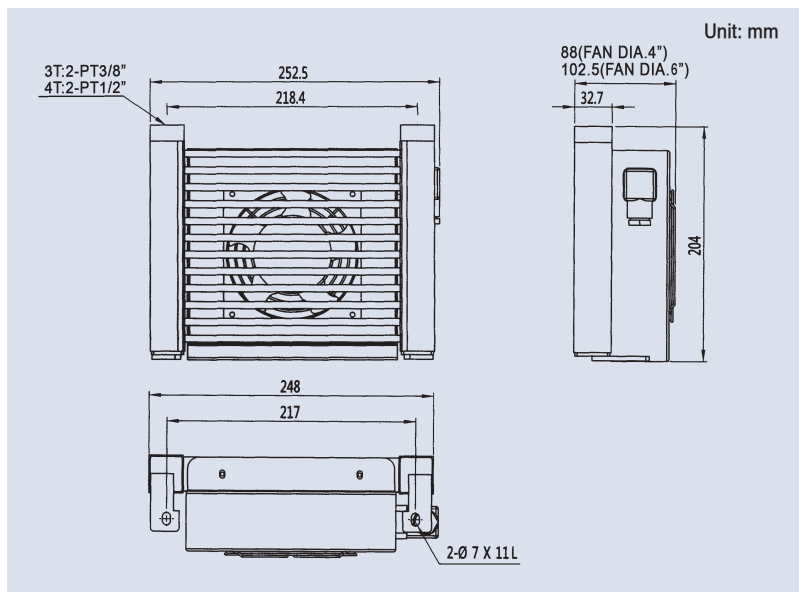

PERFORMANCE DIAGRAM

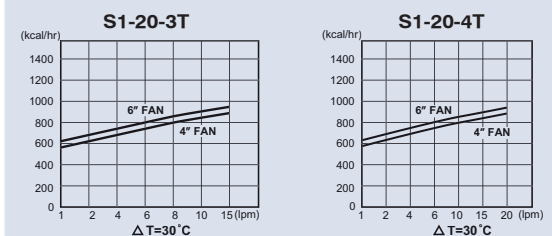

LOSS OF PRESSURE (at 32 Cst)

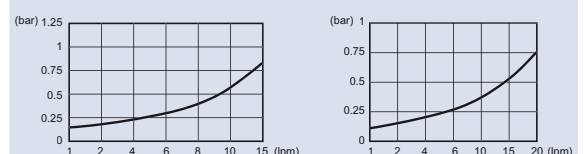
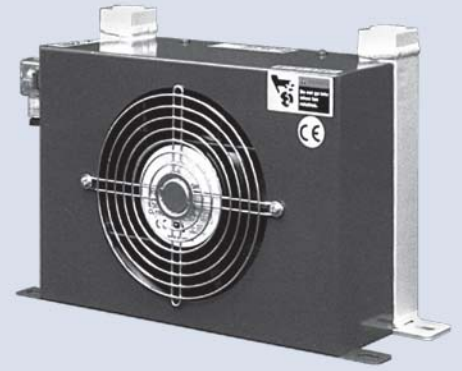

PLATE-FIN HEAT EXCHANGER



How to order

S1 - 21 - 4T 6 C A*(D*) P E

1 2 3 4 5 6 7 8

1	Series no.
2	Model
3	Port size 4T: PT 1/2"
4	Fan diameter 6: 6"
5	C: With fan case
6	Voltage D1: DC12V D2: DC24V A1: AC110V A2: AC220V A3: AC380V (50/60HZ)
7	Motor phase P: Single phase
8	E: CE approved

Specifications

Oil Flow (lpm)	Capacity $\Delta t=30^\circ\text{C}$ (Kcal/hr)	MAX. Pressure (bar)	Voltage (V $\pm 10\%$)	Frequency (Hz)	Current (A)	Power (Watt)	Rated Speed (r.p.m)	Air Flow (m ³ /hr)	Motor (IP)	Noise (dB (A))	Weight (kg)
1~20	1100	15	DC12	-	0.96	11.5	3000	384.2	54	51	3.3
			DC24	-	0.48	11.5	3000	384.2		51	
			110	50/60	0.48/0.55	45/52	2800/3100	323/374		53/59	
			220	50/60	0.28/0.35	44/51	2800/3100	323/374		53/59	
			380	50/60	0.12/0.15	46/57	2800/3100	323/374		53/59	

Dimensions/Performance curves

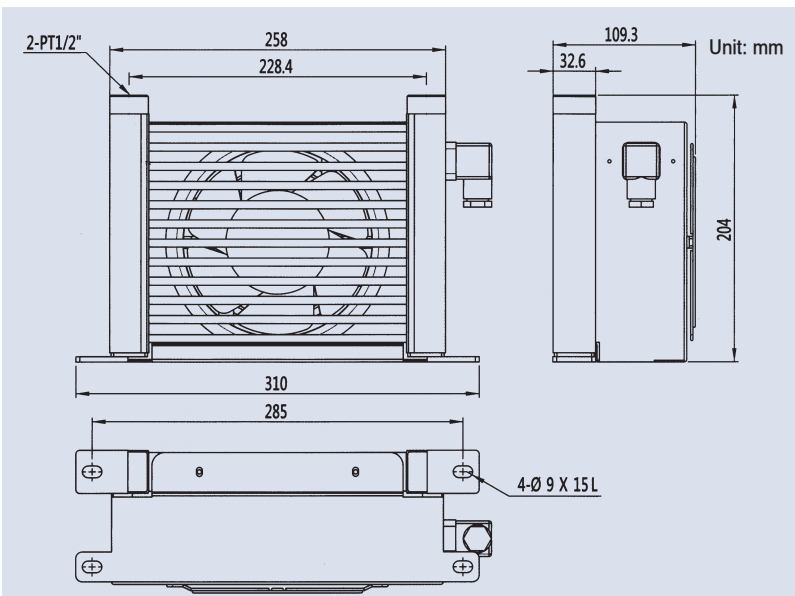

PERFORMANCE DIAGRAM

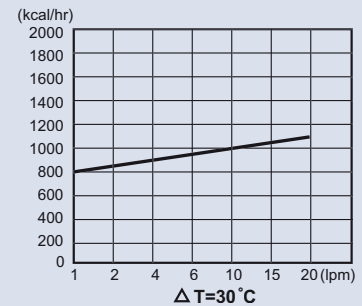

LOSS OF PRESSURE (at 32 Cst)

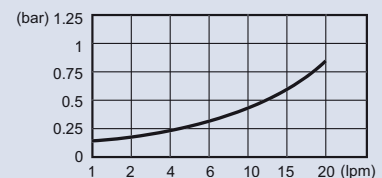

PLATE-FIN HEAT EXCHANGER



How to order

S1 - 31 - 4T 6 C A*(D*) P E

1 2 3 4 5 6 7 8

1	Series no.
2	Model
3	Port size 4T: PT 1/2"
4	Fan diameter 6: 6"
5	C: With fan case
6	Voltage D1: DC12V D2: DC24V A1: AC110V A2: AC220V A3: AC380V (50/60HZ)
7	Motor phase P: Single phase
8	E: CE approved

Specifications

Oil Flow (lpm)	Capacity $\Delta t=30^\circ\text{C}$ (Kcal/hr)	MAX. Pressure (bar)	Voltage (V $\pm 10\%$)	Frequency (Hz)	Current (A)	Power (Watt)	Rated Speed (r.p.m)	Air Flow (m ³ /hr)	Motor (IP)	Noise (dB (A))	Weight (kg)
1~20	1750	15	DC12	-	1.92	23	3000	768.4	54	51	4.7
			DC24	-	0.96	23	3000	768.4		51	
			110	50/60	0.96/1.10	90/104	2800/3100	646/748		53/59	
			220	50/60	0.56/0.70	88/102	2800/3100	646/748		53/59	
			380	50/60	0.24/0.30	70/82	2800/3100	646/748		53/59	

Dimensions/Performance curves

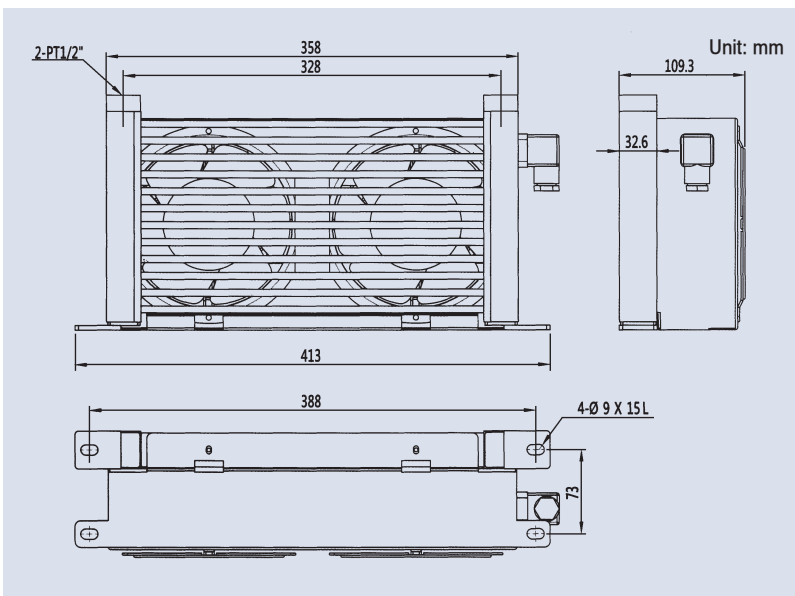

PERFORMANCE DIAGRAM

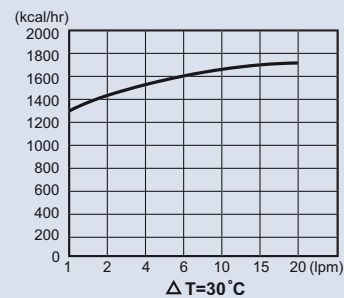

LOSS OF PRESSURE (at 32 Cst)

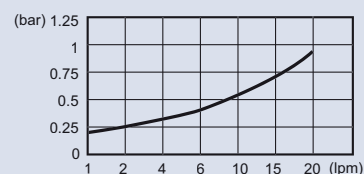

PLATE-FIN HEAT EXCHANGER



How to order

S2 - 15 - 6T 6 C A*(D*) P E

1 2 3 4 5 6 7 8

1	Series no.
2	Model
3	Port size 6T: PT 3/4"
4	Fan diameter 6: 6"
5	C: With fan case
6	Voltage D1: DC12V D2: DC24V A1: AC110V A2: AC220V A3: AC380V (50/60HZ)
7	Motor phase P: Single phase
8	E: CE approved

Specifications

Oil Flow (lpm)	Capacity $\Delta t=30^\circ\text{C}$ (Kcal/hr)	MAX. Pressure (bar)	Voltage (V $\pm 10\%$)	Frequency (Hz)	Current (A)	Power (Watt)	Rated Speed (r.p.m)	Air Flow (m ³ /hr)	Motor (IP)	Noise (dB (A))	Weight (kg)
3~60	1500	15	DC12	-	0.96	11.5	3000	384.2	54	51	4
			DC24	-	0.48	11.5	3000	384.2		51	
			110	50/60	0.48/0.55	45/52	2800/3100	323/374		53/59	
			220	50/60	0.28/0.35	44/51	2800/3100	323/374		53/59	
			380	50/60	0.12/0.15	46/57	2800/3100	323/374		53/59	

Dimensions/Performance curves

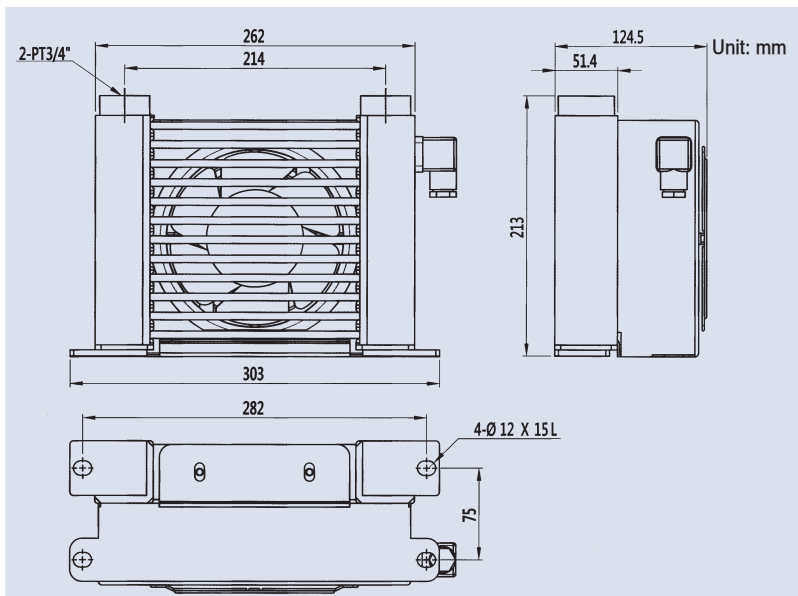

PERFORMANCE DIAGRAM

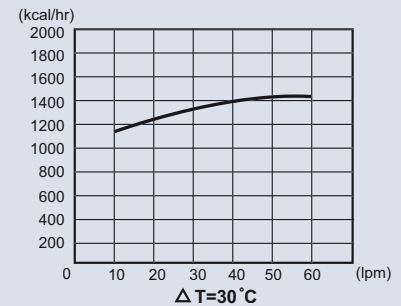

LOSS OF PRESSURE (at 32 Cst)

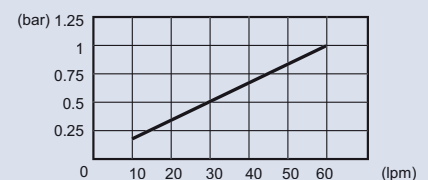

PLATE-FIN HEAT EXCHANGER



How to order

S2 - 25 - 6T 6 C A*(D*) P E

1 2 3 4 5 6 7 8

1	Series no.
2	Model
3	Port size 6T: PT 3/4"
4	Fan diameter 6: 6"
5	C: With fan case
6	Voltage D1: DC12V D2: DC24V A1: AC110V A2: AC220V A3: AC380V (50/60HZ)
7	Motor phase P: Single phase
8	E: CE approved

Specifications

Oil Flow (lpm)	Capacity $\Delta t=30\text{ }^{\circ}\text{C}$ (Kcal/hr)	MAX. Pressure (bar)	Voltage (V \pm 10%)	Frequency (Hz)	Current (A)	Power (Watt)	Rated Speed (r.p.m)	Air Flow (m ³ /hr)	Motor (IP)	Noise (dB (A))	Weight (kg)
3~60	2700	15	DC12	-	1.92	23	3000	768.4	54	51	6
			DC24	-	0.96	23	3000	768.4		51	
			110	50/60	0.96/1.10	90/104	2800/3100	646/748		53/59	
			220	50/60	0.56/0.70	88/102	2800/3100	646/748		53/59	
			380	50/60	0.24/0.30	70/82	2800/3100	646/748		53/59	

Dimensions/Performance curves

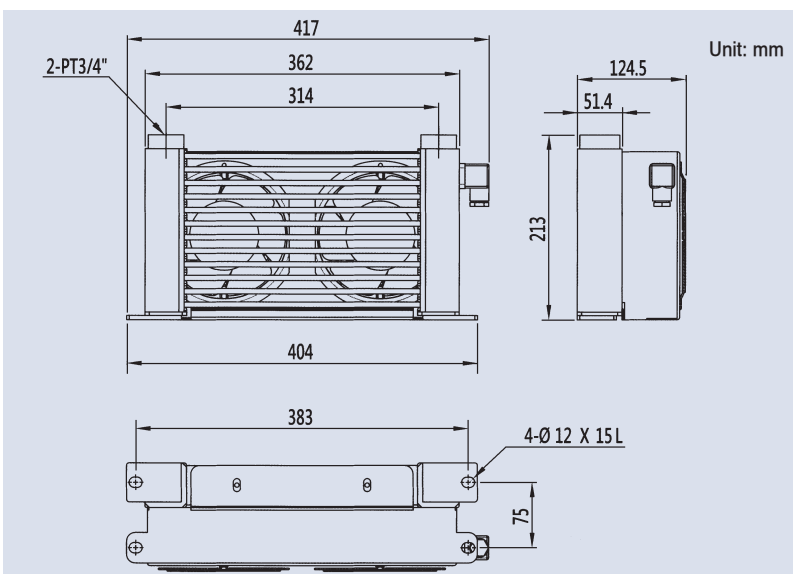

PERFORMANCE DIAGRAM

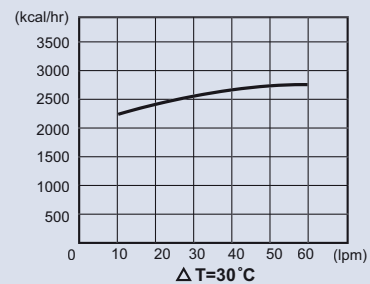

LOSS OF PRESSURE (at 32 Cst)

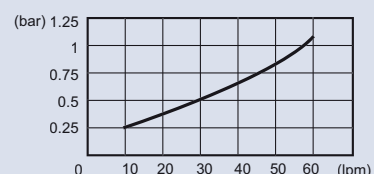

PLATE-FIN HEAT EXCHANGER



How to order

S2 - 26 - 8T 10 C A*(D*) P PP E

1 2 3 4 5 6 7 8

1	Series no.
2	Model
3	Port size 8T: PT 1"
4	Fan diameter 10: 10"
5	C: With fan case
6	Voltage D1: DC12V D2: DC24V A1: AC110V A2: AC220V A3: AC380V A23: AC220/380V (50/60HZ)
7	Motor phase P: Single phase PP: 3 phase
8	E: CE approved

Specifications

Oil Flow (lpm)	Capacity $\Delta t=30^\circ\text{C}$ (Kcal/hr)	MAX. Pressure (bar)	Voltage (V $\pm 10\%$)	Frequency (Hz)	Current (A)	Power (Watt)	Rated Speed (r.p.m $\pm 5\%$)	Air Flow (m ³ /hr)	Motor (IP)	Noise (dB (A))	Weight (kg)
20~100	6000	15	DC12	-	7.9	94.8	2325	2160	54	74.5	7.5
			DC24	-	3.95	94.8	2313	2642		74.5	
			110	50/60	0.56/0.55	62/61	1400/1600	1460/1600		55/57	9.1
			220	50/60	0.30/0.25	62/61	1400/1600	1460/1600		55/57	
			380	50/60	0.18/0.14	62/61	1400/1600	1460/1600		55/57	

Dimensions/Performance curves

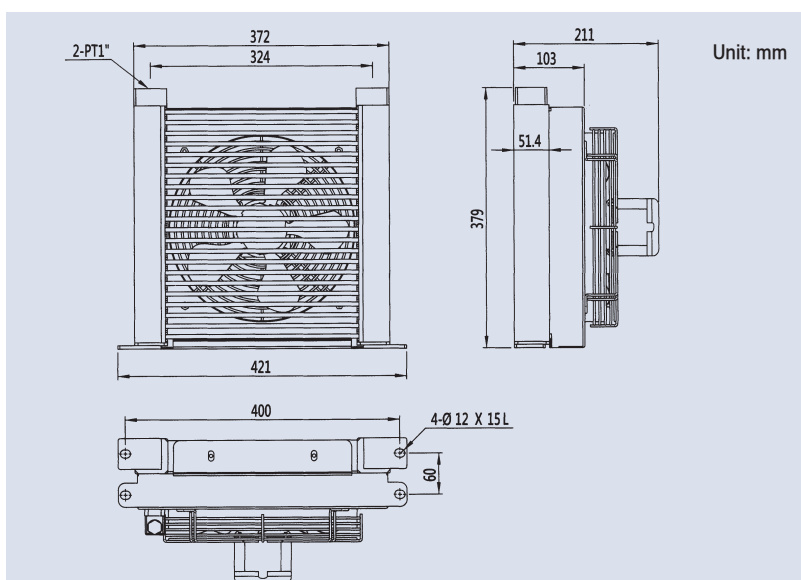

PERFORMANCE DIAGRAM

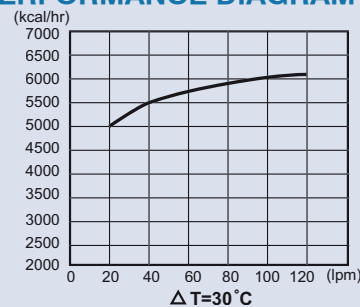

LOSS OF PRESSURE (at 32 Cst)

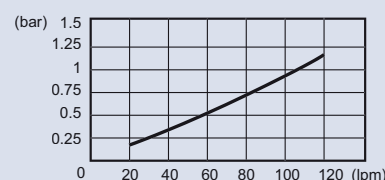

PLATE-FIN HEAT EXCHANGER



How to order

S2 - 40 - 8T 14 C A*(D*) P PP E

1 2 3 4 5 6 7 8

1	Series no.
2	Model
3	Port size 8T: PT 1"
4	Fan diameter 14: 14"
5	C: With fan case
6	Voltage D1: DC12V D2: DC24V A1: AC110V A2: AC220V A3: AC380V A23: AC220/380V (50/60HZ)
7	Motor phase P: Single phase PP: 3 phase
8	E: CE approved

Specifications

Oil Flow (lpm)	Capacity $\Delta t=30^\circ\text{C}$ (Kcal/hr)	MAX. Pressure (bar)	Voltage (V $\pm 10\%$)	Frequency (Hz)	Current (A)	Power (Watt)	Rated Speed (r.p.m $\pm 5\%$)	Air Flow (m ³ /hr)	Motor (IP)	Noise (dB (A))	Weight (kg)
30~110	12000	15	DC12	-	4.5	54	2495	1360	54	70.6	12.5
			DC24	-	2.25	54	2272	1097		74.3	
			110	50/60	1.36/1.63	150/180	1380/1550	3170/3420		62/65	15.3
			220	50/60	0.80/0.70	150/180	1380/1550	3170/3420		62/65	
			380	50/60	0.40/0.47	150/180	1380/1550	3170/3420		62/65	

Dimensions/Performance curves

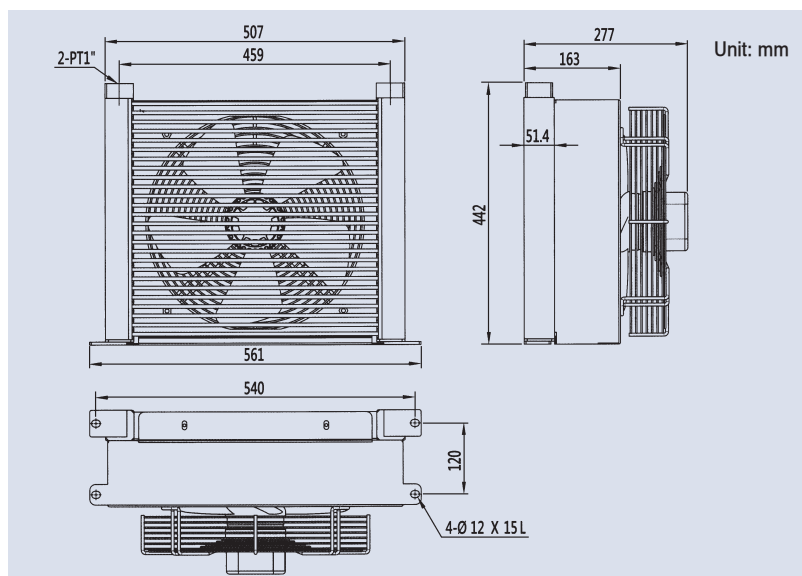

PERFORMANCE DIAGRAM

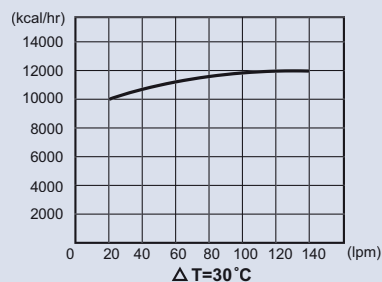

LOSS OF PRESSURE (at 32 Cst)

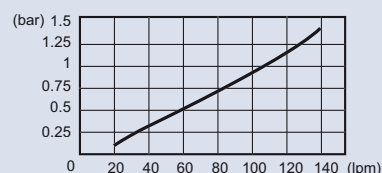

PLATE-FIN HEAT EXCHANGER



How to order

S2 - 40 - 8T 14 D A*(D*) P E

1	2	3	4	5	6	7	8
1	Series no.						
2	Model						
3	Port size 8T: PT 1"						
4	Fan diameter 14: 14"						
5	D: With small fan case						
6	Voltage D1: DC12V D2: DC24V A1: AC110V A2: AC220V (50/60HZ)						
7	Motor phase P: Single phase						
8	E: CE approved						

Specifications

Oil Flow (lpm)	Capacity $\Delta t=30^\circ\text{C}$ (Kcal/hr)	MAX. Pressure (bar)	Voltage (V $\pm 10\%$)	Frequency (Hz)	Current (A)	Power (Watt)	Rated Speed (r.p.m $\pm 5\%$)	Air Flow (m ³ /hr)	Motor (IP)	Noise (dB (A))	Weight (kg)
30~110	12000	15	DC12	-	4.5	54	2495	1360	54	70.6	10
			DC24	-	2.25	54	2272	1097		74.3	
			110	50/60	0.36/0.45	40/50	1450/1650	2700/3300		62/65	
			220	50/60	0.18/0.23	40/50	1450/1650	2700/3300		62/65	

Dimensions/Performance curves

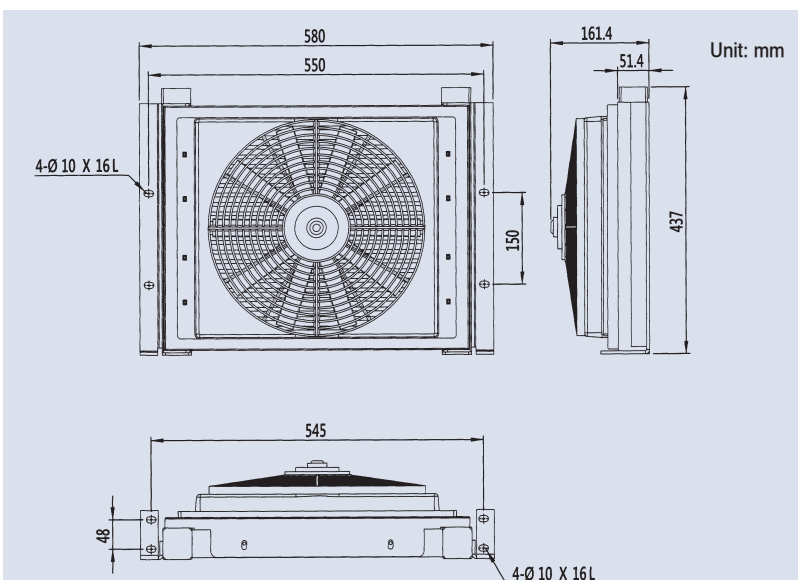

PERFORMANCE DIAGRAM

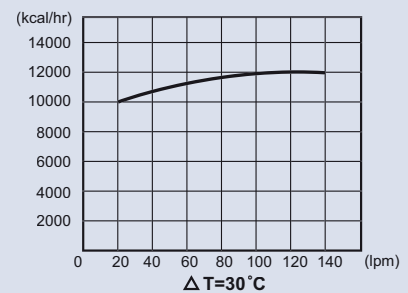

LOSS OF PRESSURE (at 32 Cst)

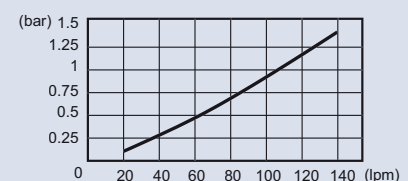

PLATE-FIN HEAT EXCHANGER



How to order

S3 - 39 - 10T 14 C A* P PP E

1 2 3 4 5 6 7 8

1	Series no.
2	Model
3	Port size 10T: PT 1-1/4"
4	Fan diameter 14: 14"
5	C: With fan case
6	Voltage A1: AC110V A2: AC220V A3: AC380V A23: AC220/380V (50/60HZ)
7	Motor phase P: Single phase PP: 3 phase
8	E: CE approved

Specifications

Oil Flow (lpm)	Capacity $\Delta t=30^\circ\text{C}$ (Kcal/hr)	MAX. Pressure (bar)	Voltage (V $\pm 10\%$)	Frequency (Hz)	Current (A)	Power (Watt)	Rated Speed (r.p.m $\pm 5\%$)	Air Flow (m ³ /hr)	Motor (IP)	Noise (dB (A))	Weight (kg)
30~150	18000	20	220	50/60	0.80/0.70	150/180	1380/1550	3170/3420	54	62/65	18.3
			380	50/60	0.40/0.36	150/180	1380/1550			62/65	

Dimensions/Performance curves

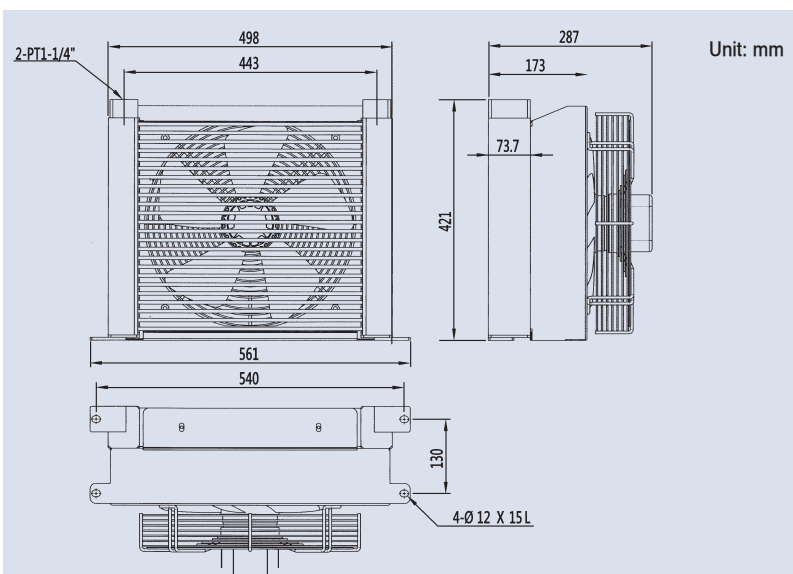

PERFORMANCE DIAGRAM

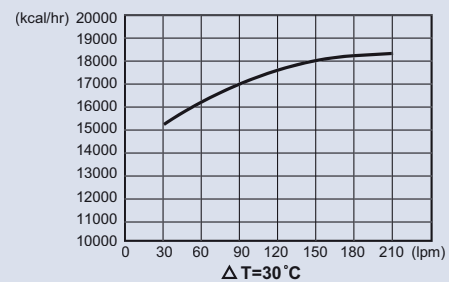

LOSS OF PRESSURE (at 32 Cst)

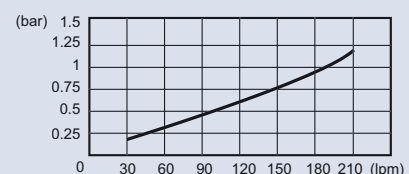

PLATE-FIN HEAT EXCHANGER



How to order

S3 - 39 - 10T 14 D A*(D*) P E

1 2 3 4 5 6 7 8

- 1 Series no.
- 2 Model
- 3 Port size 10T: PT 1-1/4"
- 4 Fan diameter 14: 14"
- 5 D: With small fan case
- 6 Voltage D1: DC12V D2: DC24V A1: AC110V A2: AC220V (50/60HZ)
- 7 Motor phase P: Single phase
- 8 E: CE approved

Specifications

Oil Flow (lpm)	Capacity $\Delta t=30^\circ\text{C}$ (Kcal/hr)	MAX. Pressure (bar)	Voltage (V $\pm 10\%$)	Frequency (Hz)	Current (A)	Power (Watt)	Rated Speed (r.p.m $\pm 5\%$)	Air Flow (m ³ /hr)	Motor (IP)	Noise (dB (A))	Weight (kg)
30~150	18000	20	DC12	-	4.5	54	2495	1360	54	70.6	12.4
			DC24	-	2.25	54	2272	1097		74.3	
			110	50/60	0.36/0.45	40/50	1450/1650	2700/3300		62/65	
			220	50/60	0.18/0.23	40/50	1450/1650	2700/3300		62/65	

Dimensions/Performance curves

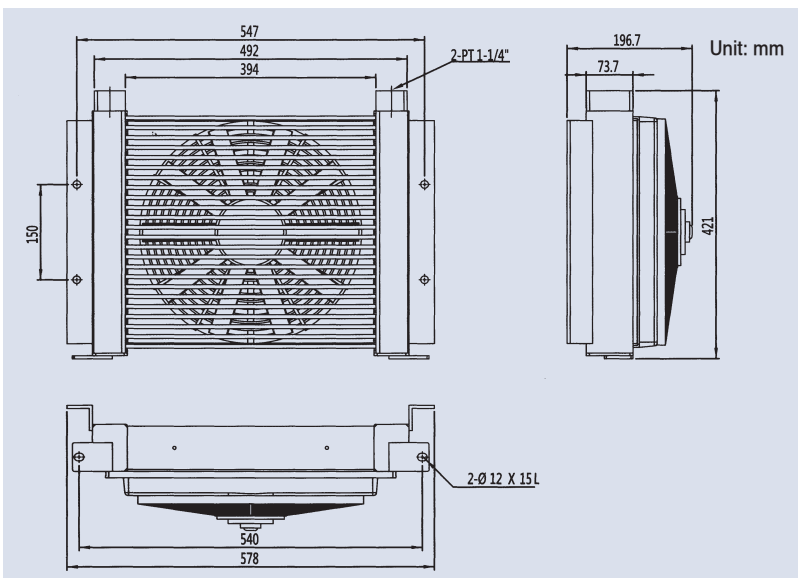

PERFORMANCE DIAGRAM

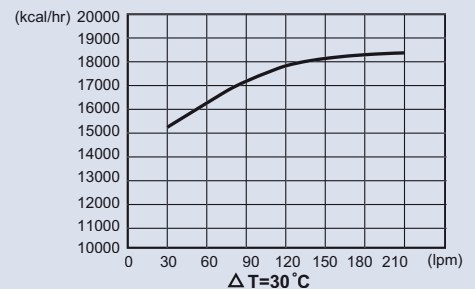

LOSS OF PRESSURE (at 32 Cst)

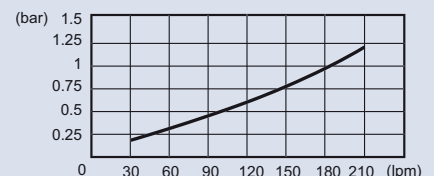

PLATE-FIN HEAT EXCHANGER



How to order

S3 - 47 - 12T 14 C A* P PP E

1 2 3 4 5 6 7 8

1	Series no.
2	Model
3	Port size 12T: PT 1-1/2"
4	Fan diameter 14: 14"
5	C: With fan case
6	Voltage A2: AC220V A3: AC380V A23: AC220/380V (50/60HZ)
7	Motor phase P: Single phase PP: 3 phase
8	E: CE approved

Specifications

Oil Flow (lpm)	Capacity $\Delta t=30^\circ\text{C}$ (Kcal/hr)	MAX. Pressure (bar)	Voltage (V $\pm 10\%$)	Frequency (Hz)	Current (A)	Power (Watt)	Rated Speed (r.p.m $\pm 5\%$)	Air Flow (m ³ /hr)	Motor (IP)	Noise (dB (A))	Weight (kg)
30~200	23000	20	220 380	50/60	0.80/0.70 0.40/0.36	150/180	1380/1550	3200/3800	54	62/64	24.2

Dimensions/Performance curves

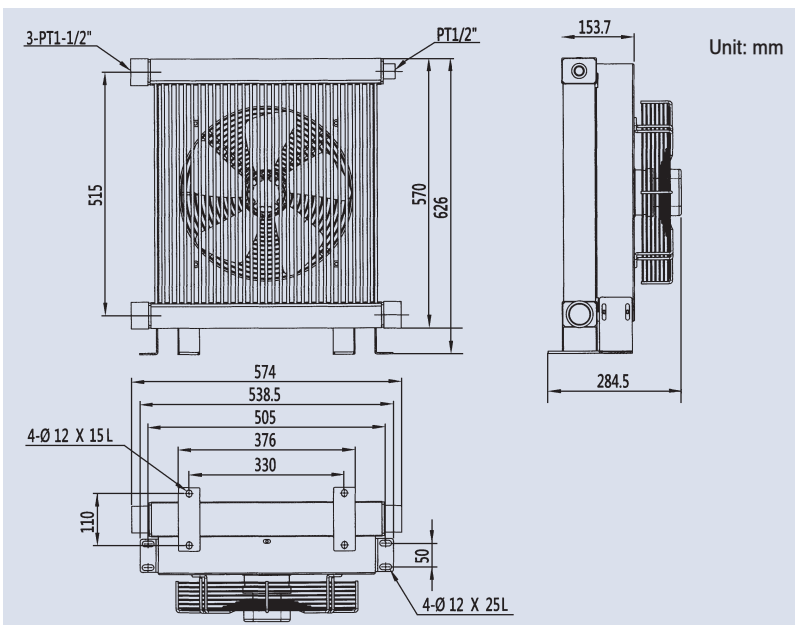

PERFORMANCE DIAGRAM

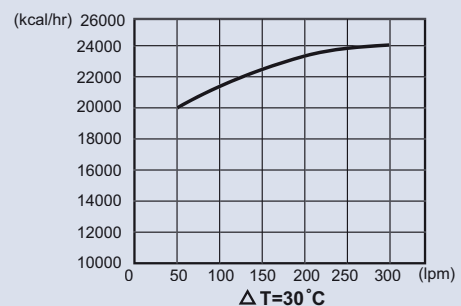

LOSS OF PRESSURE (at 32 Cst)

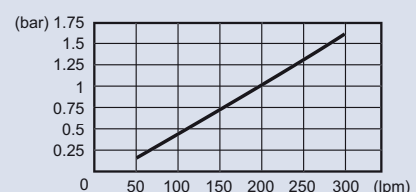

PLATE-FIN HEAT EXCHANGER



How to order

S4 - 48 - 12T 16 C A* P PP E

1 2 3 4 5 6 7 8

- 1 Series no.
- 2 Model
- 3 Port size 12T: PT 1-1/2"
- 4 Fan diameter 16: 16"
- 5 C: With fan case
- 6 Voltage A2: AC220V A3: AC380V A23: AC220/380V (50/60HZ)
- 7 Motor phase P: Single phase PP: 3 phase
- 8 E: CE approved

Specifications

Oil Flow (lpm)	Capacity $\Delta t=30^\circ\text{C}$ (Kcal/hr)	MAX. Pressure (bar)	Voltage (V $\pm 10\%$)	Frequency (Hz)	Current (A)	Power (Watt)	Rated Speed (r.p.m $\pm 5\%$)	Air Flow (m ³ /hr)	Motor (IP)	Noise (dB (A))	Weight (kg)
30~250	28000	20	220 380	50/60	0.90/1.0 0.50/0.53	145/250	1380/1550	4000/4800	54	62/64	29.4

Dimensions/Performance curves

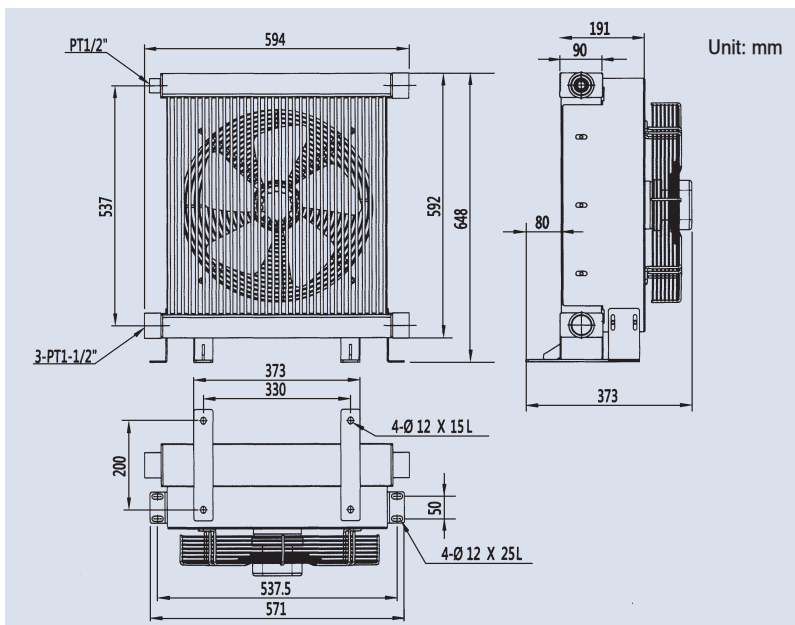

PERFORMANCE DIAGRAM

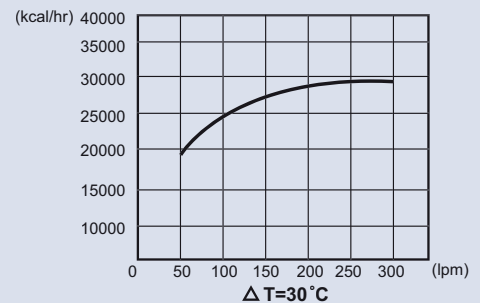

LOSS OF PRESSURE (at 32 Cst)

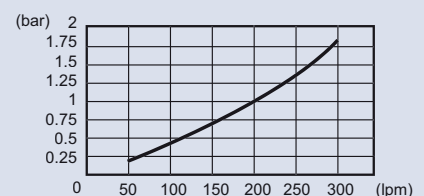

PLATE-FIN HEAT EXCHANGER



How to order

S4 - 63 - 12T 18 C A23 PP E

1 2 3 4 5 6 7 8

1	Series no.
2	Model
3	Port size 12T: PT 1-1/2"
4	Fan diameter 18:18"
5	C: With fan case
6	Voltage A23: AC220V/380V (50/60HZ)
7	Motor phase PP: 3 phase
8	E: CE approved

Specifications

Oil Flow (lpm)	Capacity $\Delta T=30^{\circ}\text{C}$ (Kcal/hr)	MAX. Pressure (bar)	Voltage (V $\pm 10\%$)	Frequency (Hz)	Current (A)	Power (kw)	Rated Speed (r.p.m $\pm 5\%$)	Air Flow (m ³ /hr)	Motor (IP)	Noise (dB (A))	Weight (kg)
50~300	35000	20	220 380	60	5.7 3.3	1.25	1720	7600	55	78	52

Dimensions/Performance curves

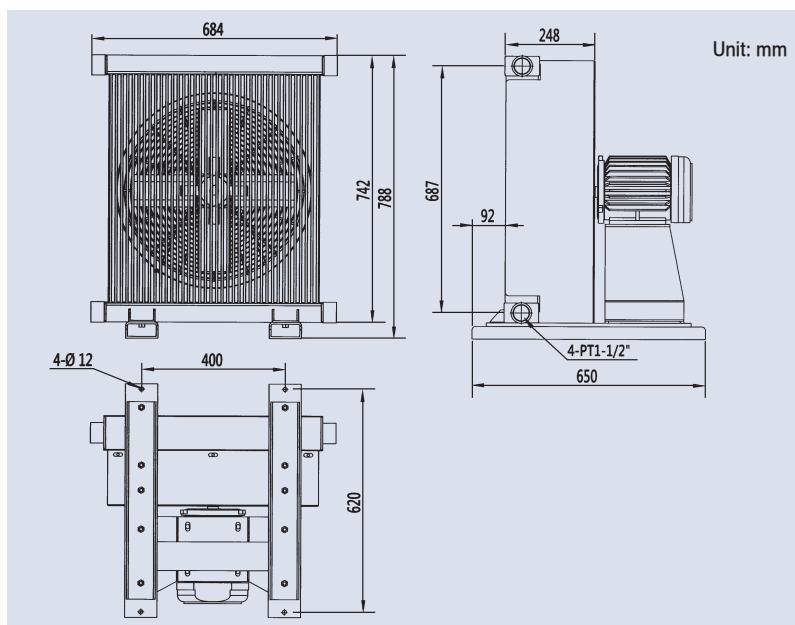

PERFORMANCE DIAGRAM

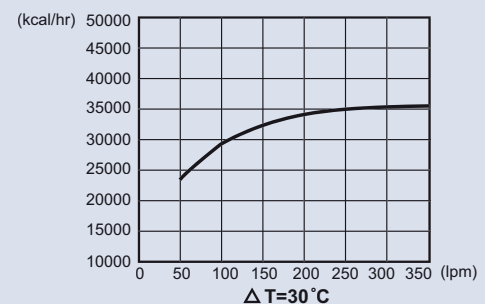

LOSS OF PRESSURE (at 32 Cst)

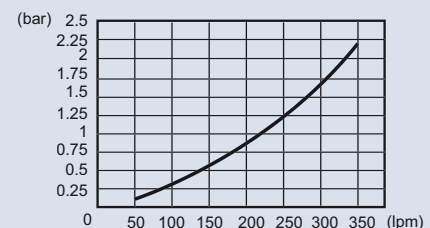

PLATE-FIN HEAT EXCHANGER



How to order

S4 - 70 - 12T 23 C A23 PP E

1 2 3 4 5 6 7 8

1	Series no.
2	Model
3	Port size 12T: PT 1-1/2"
4	Fan diameter 23: 23"
5	C: With fan case
6	Voltage A23: AC220V/380V (50/60HZ)
7	Motor phase PP: 3 phase
8	E: CE approved

Specifications

Oil Flow (lpm)	Capacity $\Delta t=30^{\circ}\text{C}$ (Kcal/hr)	MAX. Pressure (bar)	Voltage (V $\pm 10\%$)	Frequency (Hz)	Current (A)	Power (kw)	Rated Speed (r.p.m $\pm 5\%$)	Air Flow (m ³ /hr)	Motor (IP)	Noise (dB (A))	Weight (kg)
50~350	40000	20	220 380	60	5.7 3.3	1.25	1720	8560	55	90	80

Dimensions/Performance curves

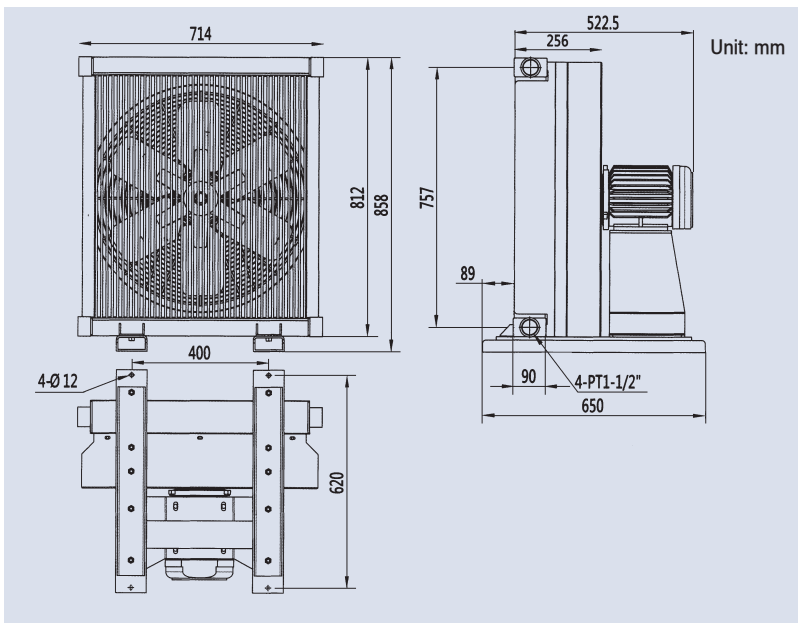

PERFORMANCE DIAGRAM

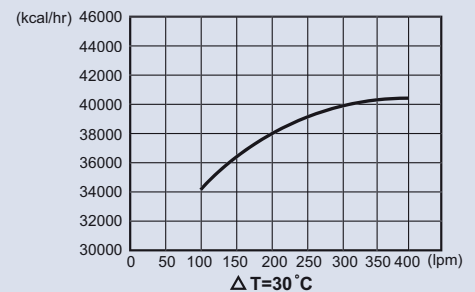

LOSS OF PRESSURE (at 32 Cst)

