

# SYNCHRONOUS FLOW DIVIDER

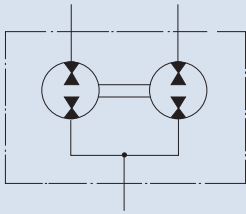

Symbol

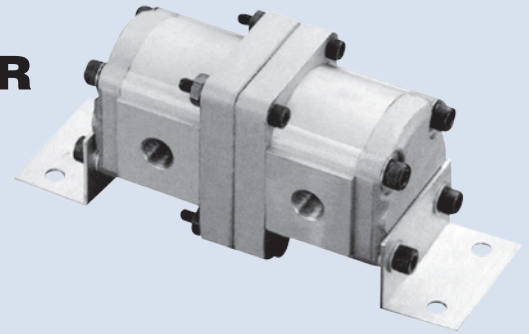

## How to order

### DFM - 3 - 02A - 11

1	2	3	4
1	Model		
2	Series number		
3	Stations	02A: 2 Stations	03A: 3 Stations 04A: 4 Stations
4	Displacement (cc/rev)	4 cc/rev ~ 35 cc/rev	

## Specifications

Model	Displacement (cc/rev)	Max. Pressure bar (psi)	Speed (rpm)		Port Size		A(mm)	B(mm)	Weight (kg)
			Loaded	Unloaded	In	Out			
DFM-302A-6*	6	210 (3000)	1200	2000	PT 3/4"	PT 1/2"	52	263.6	4.6
DFM-302A-8*	8.4						55	269.6	4.7
DFM-302A-11*	11						60	279.6	4.98
DFM-302A-13*	13						64	287.6	4.98
DFM-302A-14*	14.3						66	291.6	5.53
DFM-302A-17*	16.5						70	299.6	5.53
DFM-302A-19*	19.2						74	303.6	6.13
DFM-302A-23*	23				81	321.6	6.13		
DFM-302A-25*	25				84	327.6	6.13		
DFM-302A-28*	28				88	335.6	6.67		
DFM-302A-30*	30				92	313.6	6.67		
DFM-302A-35*	35				102	323.6	6.9		

## Dimensions

### DFM-302A

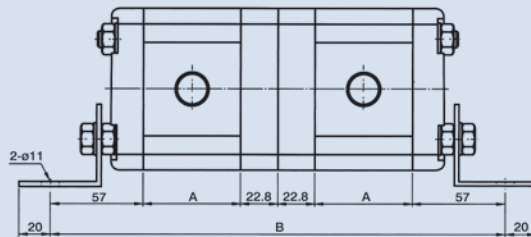

Unit:mm

### DFM-304A

