

# AT-Pneumatik



*Progressive!*



All innovation  
on driving your valve automation

**ALL-TECHNIK**  
& Components, Incorporated





















# Contents

**A solid workhorse you can depend on for consistent, reliable control**

◆ APPLICATIONS & INSTALLATIONS			61 --- 62
◆ SOLENOID VALVE	ESV-S & D (Ex d, SS316, 5/2 way)		E2
	ESV-3 & 3S (Ex d, SS316, 3/2 way)		E3
	ESV-31 & 31S (Ex d, SS316, 3/2way)		E4
	ESV-10		E7 --- E8
◆ AIR FILTER REGULATOR	FR10		F2
	FR20		F3
	FR30		F4
◆ AIR VOLUME BOOSTER	AVB-1000		V2 --- V3
	AVB-2000 (Ex d, SS316)		V4 --- V5
	AVB-3000 (Ex d, SS316)		V6 --- V7
◆ VALVE POSITION MONITOR	LSB-1000		L2
	LSB-3000		L3
	LSB-7000		L4 --- L5
	LSB-2000		L10

# Certificates

## Explosion-proof Certificates

Model	Explosion-proof	Certification	Certification No.
<b>Electro-Pneumatic Positioner</b>			
EP Series	Ex dmb IIB+H <sub>2</sub> T6	KC	10-AV2BO-0588 / 0697
	Ex dmb IIB+H <sub>2</sub> T6	NEPSI	GYJ111237
	Ex dmb IIC T6 / T5	KC	13-KB2BO-0469
	Ex dmb IIC T6 / T5	ATEX	INERIS 14ATEX0062X
	Ex dmb IIC T6 / T5	IECEX	IECEX KTL 13.0010
	Ex dmb IIC T6 / T5	TR-CU	TCRU C-KR 08.B.00646
	Ex ia IIC T6	KC	12-KB2BO-0060X
	Ex ia IIC T6	ATEX	INERIS 12ATEX0030X
	Ex ia IIC T6	IECEX	IECEX KTL 11.0012X
	Ex ia IIC T6	TR-CU	TCRU C-KR 08.B.00646
	Ex ia IIC T6	NEPSI	GYJ111238
<b>Smart Valve Positioner</b>			
SS2 Series	Ex ia IIC T6 / T5	KC	13-KB2BO-0155X
	Ex ia IIC T6 / T5	ATEX	INERIS 13ATEX0046X
	Ex ia IIC T6 / T5	IECEX	IECEX KTL 13.0002X
	Ex ia IIC T6 / T5	TR-CU	TCRU C-KR 08.B.00646
<b>Smart Valve Positioner</b>			
SS3 Series	Ex d IIC T6	KC	KTL 12-KB2BO-0002
	Ex d IIC T6	ATEX	INERIS 13ATEX0038X
	Ex d IIC T6	IECEX	IECEX KTL 11.0020
	Ex d IIC T6	TR-CU	TCRU C-KR 08.B.00646
<b>Smart Valve Positioner</b>			
SS/SE Series	Ex dmb IIB+H <sub>2</sub> T6	KC	11-AV2BO-0155/0156
<b>Solenoid Valve</b>			
ESV Series	Ex d IIC T6 / T5	KC	13-KB2BO-0150
	Ex d IIC T6 / T5	ATEX	In progress
	Ex d IIC T6 / T5	IECEX	In progress
	Ex d IIC T6 / T5	NEPSI	GYJ111239
<b>Position Transmitter</b>			
PTP Series	Ex d IIC T6	KC	13-KB2BO-0149
<b>Valve Position Monitor</b>			
LSB-3000 Series	Ex d IIC T6 / T5 / T4	KC	14-KB2BO-0080
	Ex d IIC T6 / T5 / T4	ATEX	INERIS 14ATEX0060X
	Ex d IIC T6 / T5 / T4	IECEX	IECEX KTL 14.0013
	Ex d IIC T6 / T5 / T4	TR-CU	TCRU C-KR 08.B.00646
LSB-7000 series	Ex dmb IIB+H <sub>2</sub> T6	KC	12-KB2BO-0001X
	Ex dmb IIB+H <sub>2</sub> T6	ATEX	INERIS 12ATEX0075X
	Ex dmb IIB+H <sub>2</sub> T6	IECEX	IECEX KTL 11.0021X
	Ex dmb IIB+H <sub>2</sub> T6	TR-CU	TCRU C-KR 08.B.00646

# Certificates

## Test Reports

Model	IP Class	Certification	Certification No.
<b>Electro-Pneumatic Positioner</b>			
EP Series	IP66	KC	10-AV2BO-0588 / 0697
<b>Smart Valve Positioner</b>			
SS2 Series	IP66	KC	2011 - 1455 - 449
SS3 Series	IP66	KC	13 - 004527 - 01
SS/SE Series	IP66	KC	11-AV2BO-0155 / 0156
<b>Solenoid Valve</b>			
ESV Series	IP66	KC	16 - 031002 - 01
<b>Valve Position Monitor</b>			
LSB-1000 Series	IP66	KC	STC - B15 - 074 - 01
	IP67	KC	14 - 010684 - 04
	IP68	KC	14 - 010684 - 03
LSB-3000 Series	IP66	KC	STC - B15 - 074 - 02
	IP67	KC	14 - 010684 - 02
	IP68	KC	14 - 010684 - 01
LSB-7000 series	IP66	KC	14 - 049973 - 01
	IP67	KC	13 - 001213 - 01

## Other Certificates

QA International / ISO 9001 : 2008
IECEX / QAR
HART / Membership
HART / DD Registration
HART / EDD Registration
PROFIBUS / Membership
PROFIBUS / Device Registration
Foundation Fieldbus / Membership
Foundation Fieldbus / Device Registration
INNO - BIZ

**Smart performance with innovative and ever-strong coil drive even under harsh working environments**

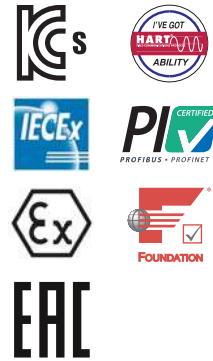

## Features

- ▶ Easy and quick auto-calibration
- ▶ Detecting RA (reverse acting) or DA (direct acting) automatically regardless of wrong air connections
- ▶ Available to use for single or double acting without any special adjustments
- ▶ Compact design allowing to be installed on small actuators
- ▶ Providing error messages against performance failures
- ▶ Possible to test the actuator with any fixed signal under a test mode
- ▶ Programmable characteristic curve with 17 points
- ▶ Wide operating temperature range -30 ~ +80 °C
- ▶ Improved control of high-friction globe and ball valves by eliminating an overshoot and a hunting
- ▶ Low air consumption
- ▶ Providing a mounting bracket to meet IEC 60534-6-1 for linear valves
- ▶ Supporting a NAMUR mounting pattern VDI/VDE 3845 (IEC 60534-6-2) and providing a multi-size mounting bracket for rotary valves

## Options

- ▶ Output position transmitter (4 - 20 mA)
- ▶ 2 x alarm limit or micro switch (SPDT)
- ▶ Low temperature (- 40°C)
- ▶ Intrinsically safe type (IECEx / ATEX / TR-CU / KC Ex ia IIC T6/T5)
- ▶ HART communication
- ▶ Profibus PA communication
- ▶ Foundation Fieldbus communication

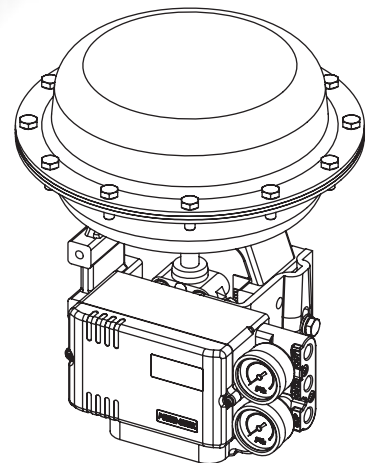

**- SS2L (Linear Type)**

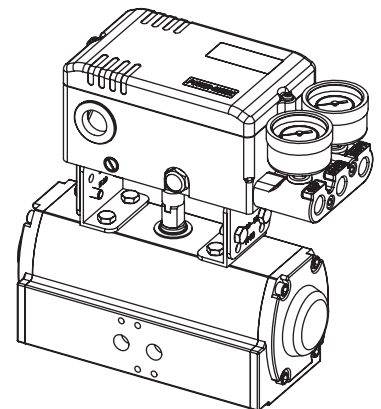

**- SS2R (Rotary Type)**

## Specifications

Communication	Without	HART	Profibus - PA	Foundation Fieldbus
Input Signal / Bus voltage	4 - 20 mA @ 24 VDC		9 - 32 VDC	
Min. / Max. Current	3.6 mA / 50 mA		-	
Current Consumption	-		15mA	16mA
Voltage Drop (Resistance)	8.7 VDC(435Ω)	9.4 VDC(470Ω)	-	
Stroke / Angle	Linear type : 5 - 130 mm * Rotary type : 25 - 120°			
Air Supply Pressure	1.4 - 7.0 bar ( 20 - 100 psi ), filtered, compressed dry and non-oiled to meet Class 3 of ISO 8573-1			
Output Pressure Range	0 - 100% of supply air pressure			
Air Capacity	80 l/min = 4.8 N <sup>m</sup> /h = 2.8 scfm (Sup = 1.4 bar) 233 l/min = 14 N <sup>m</sup> /h = 8.2 scfm (Sup = 6 bar)			
Air Consumption	2.8 l/min = 0.17 N <sup>m</sup> /h = 0.1 scfm (Sup = 1.4 ~ 6 bar)			
Characteristic	Linearity < ±0.3% F.S Hysteresis < 0.2% F.S		Sensitivity < 0.2% F.S Repeatability < 0.2% F.S	
Performance Characteristic	Linear, EQ %, Quick open, User set (17 points)			
LCD Indication	4-digit LCD indicator			
Adjustable Speed	1 - 1000 (lowest 1, highest 1000)			
Scan Time	2ms			
Shut-off Value	Range 0 - 10% of position signal			
Valve Action	direct action (DA) / reverse action (RA)			
Operating Temperature	- 30 ~ +80 °C (- 22 ~ +176 °F) **			
Pneumatic Connections	PT(Rc) 1/4 or NPT 1/4			
Electrical Connections	2 x PF(G) 1/2 , NPT 1/2 , M20 x 1.5			
Protection Class	IP66, Intrinsically safe (IECEX / ATEX / KC Ex ia IIC T6/T5)			
Body Material	Aluminum die-cast / powder-painted			
Weight	1.6 kg			

\* Up to 200mm on request    \*\* -40 °C on request

## Principle of Operation

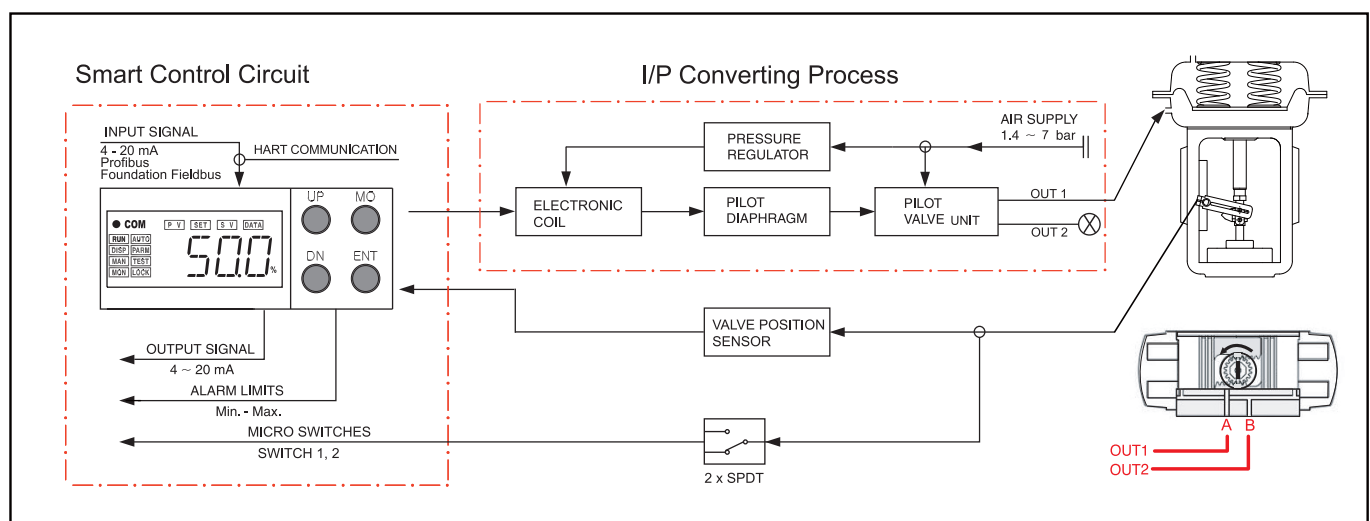

If 4-20 mA input signal(or Bus communication signal) is supplied, the micro processor compares input signal with position feedback and sends control signal to the I/P converting module. Pneumatic signal from the I/P converting module operates the valve and the valve stays at the desired position.



## Mounting to Linear Actuator

### - SS2L (Linear Type)

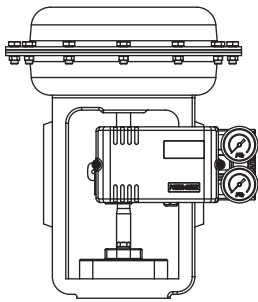

< Front View >

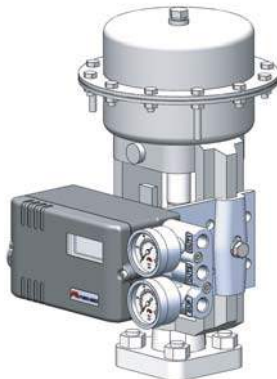

< Side View >

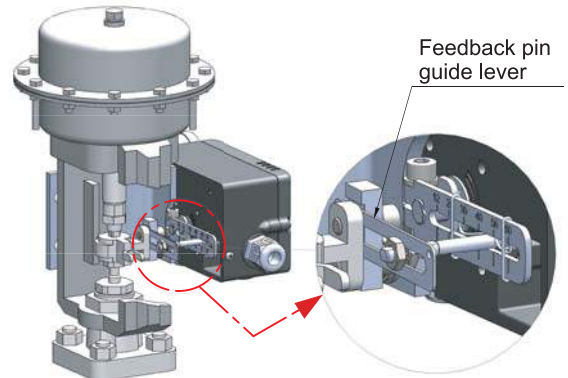

< Feedback Lever Connection >

#### "A" Type

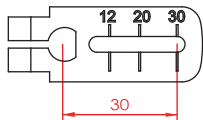

#### "B" Type

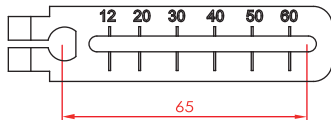

#### "C" Type

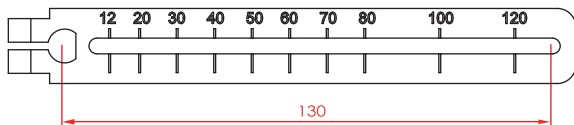

Feedback Lever

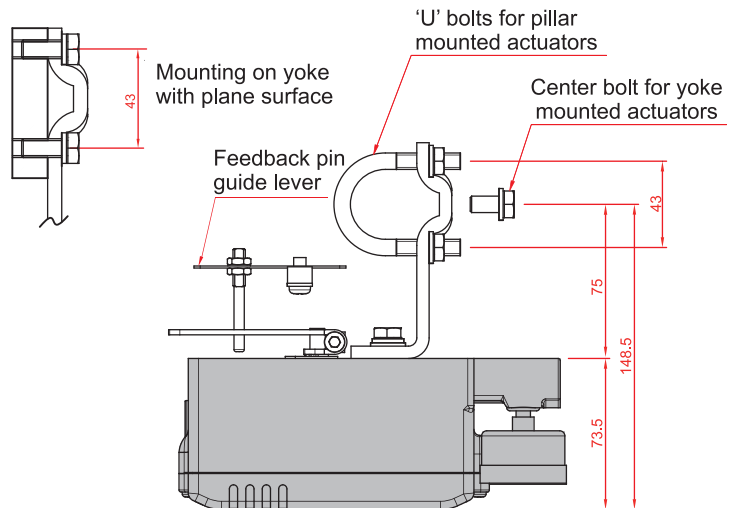

Mounting to linear actuators to IEC 60534 6-1

## Mounting to Rotary Actuator

### - SS2R (Rotary Type)

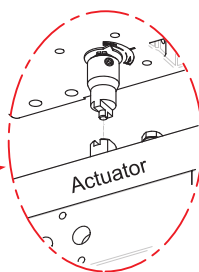
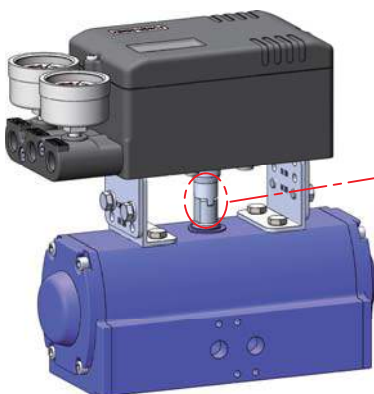

**NAMUR Type Mounting**  
( VDI/VDE 3845,  
IEC 60534-6-2 )

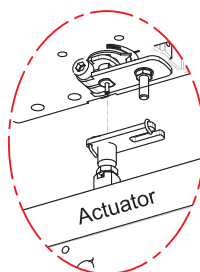

**Fork Lever Type Mounting**

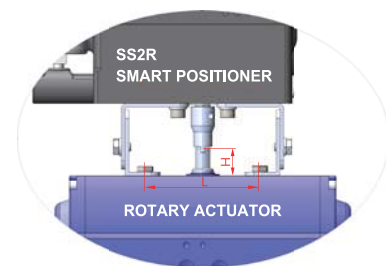

**Size Variation of Multi-Size Bracket**

- 1) 80 x 30 x 20 (H) , 4) 130 x 30 x 20 (H)
- 2) 80 x 30 x 30 (H) , 5) 130 x 30 x 30 (H)
- 3) 80 x 30 x 50 (H) , 6) 130 x 30 x 50 (H)

H : Rotary Actuator Shaft Height  
L : Length ( 80 or 130mm )

## Air Connections

### - SS2L (Linear Type)

Direct Acting (DA)		Reverse Acting (RA)	
<p><b>DA 1</b></p> <p>As the input signal increases, Valve stem moves downwards</p> <p>Actuator : DA</p>	<p>OUT2 must be plugged</p>	<p><b>RA 1</b></p> <p>As the input signal increases, Valve stem moves upwards</p> <p>Actuator : RA</p>	<p>OUT2 must be plugged</p>
<p><b>DA 2</b></p> <p>As the input signal increases, Valve stem moves downwards</p> <p>Actuator : DA</p>	<p>OUT1 must be plugged</p>	<p><b>RA 2</b></p> <p>As the input signal increases, Valve stem moves upwards</p> <p>Actuator : RA</p>	<p>OUT1 must be plugged</p>
<p><b>DA 3</b></p> <p>As the input signal increases, Valve stem moves downwards</p>		<p><b>RA 3</b></p> <p>As the input signal increases, Valve stem moves upwards</p>	

### - SS2R (Rotary Type)

Spring Return	Double Acting	Double Acting
<p>Actuator : RA</p> <p>OUT2 must be plugged</p>	<p>Actuator : RA</p>	<p>Actuator : DA</p>
<p>As the input signal increases, Actuator shaft rotates counter-clockwise</p>	<p>As the input signal increases, Actuator shaft rotates counter-clockwise</p>	<p>As the input signal increases, Actuator shaft rotates clockwise</p>

	Spring Return	Double Acting
Reverse Acting	Out 1 : piped, Out2 : plugged	Out 1 : piped to Actuator port A, Out2 : piped to Actuator port B
Direct Acting	Out 1 : plugged, Out2 : piped	Out 1 : piped to Actuator port B, Out2 : piped to Actuator port A

## SS2 Front Cover Removed

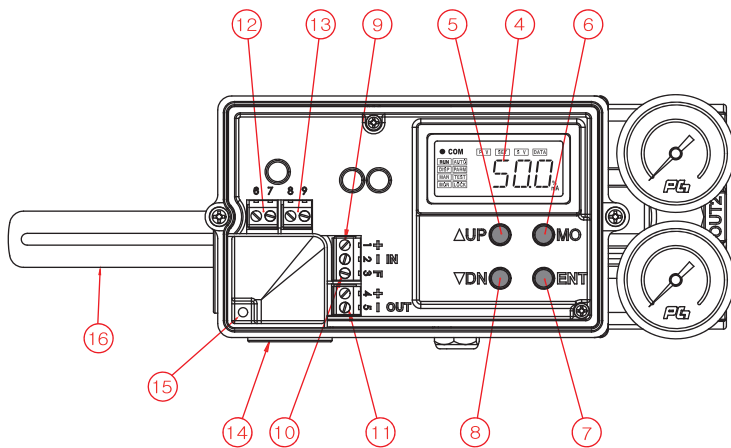

- 1 : Air supply
- 2 : OUT 1
- 3 : OUT 2
- 4 : Display LCD
- 5 : Up key
- 6 : Mode key
- 7 : Enter key
- 8 : Down key
- 9 : Input signal (+, -)
- 10 : Frame ground
- 11 : Output signal (+, -)
- 12 : Alarm limit 1
- 13 : Alarm limit 2
- 14 : Electrical connections
- 15 : Ground
- 16 : Feedback lever

## Electrical Connections

- 1 (+) } IN. 4-20mA input signal
- 2 (-) }
- 3 (FG) } Frame Ground
- 4 (+) } OUT. 4-20mA output signal
- 5 (-) }
- 6 (+) } LS1. (Low) Alarm limit 1
- 7 (-) }
- 8 (+) } LS2. (High) Alarm limit 2
- 9 (-) }

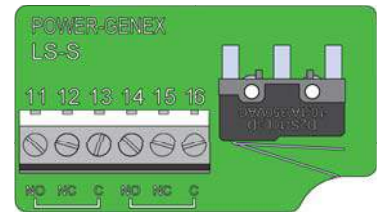
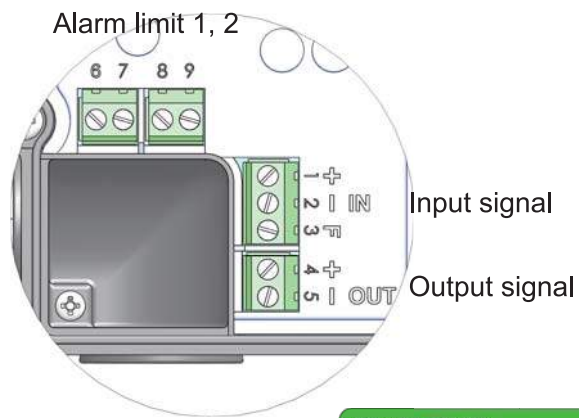

Micro switches 1, 2

## Characteristic Curves

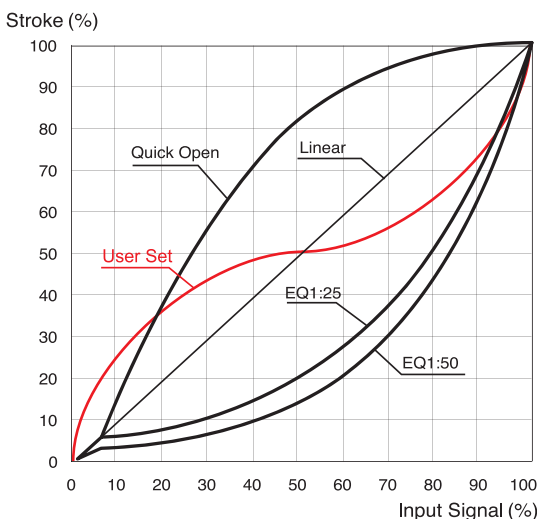

## Quick Start and Checking

	Button	Action
Auto - Calibration	MO	Push 5 seconds for auto-calibration
Span	VDN → ENT or VDN → ΔUP ENT → MO	Push VDN 5 seconds to change a measured span (Try this option only when a valve doesn't reach a desired position)
Ambient Temp.	ENT	Confirm an ambient temperature surrounding this smart valve positioner

## Parameters Diagram

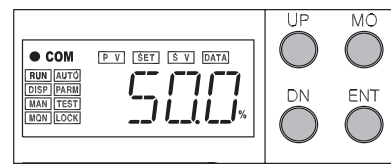
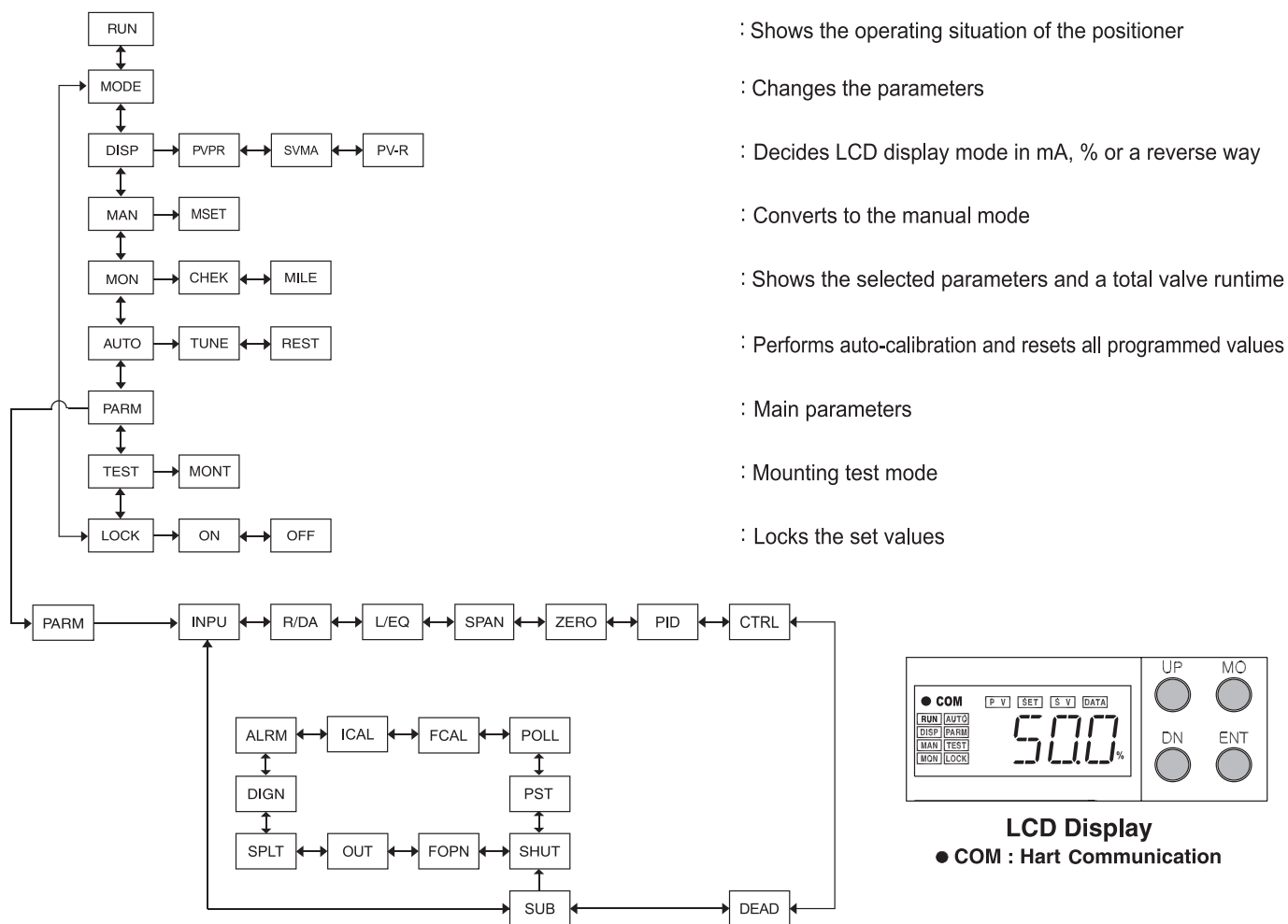

**LCD Display**

● COM : Hart Communication

Parameter	Description	Fcution	Default
INPU	Input signal	4 ~ 20mA or 20 ~ 4mA	4 ~ 20mA
R/DA	RA/DA	Reverse acting or direct acting	Auto-set
L/EQ	Characteristic	Linear, E.Q.%(1:25 or 1:50), Quick open or User set(17points)	Linear
SPAN	Span adjustment	0 ~ 100%	100%
ZERO	Zero adjustment	0 ~ 99%	0%
PID	P-GN / I-GN / D-GN	Proportional / Integral / Differential gain value	Auto-set
SPED	Response speed	1 ~ 1000	1000
SWST	Slow start	Smooth operation (ON or OFF)	Auto-set
CNLT	Control limit	50 ~ 1250	Auto-set
GCNL	Gap control limit	50 ~ 1250	Auto-set
DEAD	Dead band	0 ~ 9.99%	0.5%
HDGP	D-gain setting for hard mode	D-Gain setting for hard mode	Auto-set
SHUT	Shut-off	0 ~ 9.9%	0.3%
FOPN	Full-open	0 ~ 9.9%	0.3%
OUT	Output signal	4 ~ 20mA or 20 ~ 4mA	4 ~ 20mA
SPLT	Split range	4 ~ 12mA or 12 ~ 20mA	4 ~ 20mA
DIGN	Display place	Movement to one or two decimal places	1
ALAM	Alarm limit low, high	AL1L / AL1H / AL2L / AL2H	0 ~ 10%, 90 ~ 105%
ICAL	IN4M / IN20	Internal match with 4~20mA input signals from a calibrator	Factory setting
FCAL	FB4M / FB20	Internal match with 4~20mA output signals to a calibrator	Factory setting
POLL	Polling address	HART Communication polling address (0 ~ 15)	0
PST	Partial stroke test	Checks a valve status	OFF

## Wiring Alarm Limits

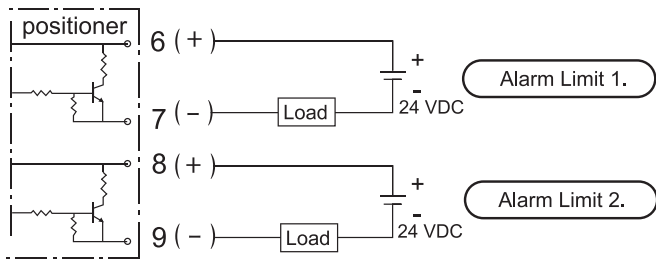

Note that 24 VDC should be supplied for power.

## Micro Switches (SPDT)

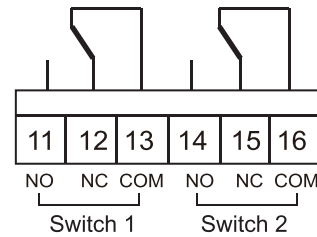

## Measuring Output Signal

① With mA loop calibrator

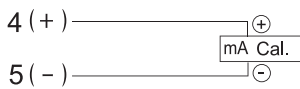

② With multimeter (mA)

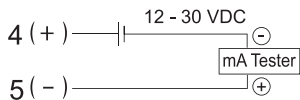

ZERO and SPAN of position feedback are automatically set after auto-calibration process.

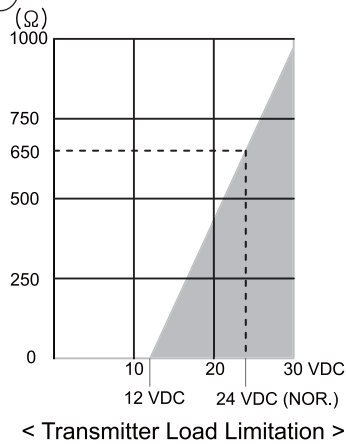

## Micro Switches

Type	SPDT
Rating	10.1A @ 250 VAC
Ambient Temperature	-30 ~ +85 °C
<b>Position Transmitter</b>	
Output Signal	4 - 20 mA, 2-wire
Power Supply	12 - 30 VDC
Output Current Limit	30 mA DC
Linearity	1% F.S
Operating Temperature	-40 ~ +80 °C

## How to Order

# SS2

Actuator Operation	Protection Class	Feedback Lever	Pressure Gauges	By-pass	Position Feedback	Communication	Connection Threads	Mounting Bracket	Feedback Pin Guide Lever Set
--------------------	------------------	----------------	-----------------	---------	-------------------	---------------	--------------------	------------------	------------------------------

Description	Code
<b>Actuator Operation :</b>	L : Linear type R : Rotary type
<b>Protection Class :</b>	I : Intrinsically safe IECEX / ATEX / TR-CU Ex ia IIC T6/T5 K : Intrinsically safe KC - Ex ia IIC T6/T5 W : Weatherproof to IP66
<b>Feedback Lever :</b> - Linear type :	A : Stroke (5~30mm) B : Stroke (5~65mm) C : Stroke (5~130mm) D : Stroke (80~200mm)
- Rotary type :	F : Fork lever N : NAMUR shaft (direct mounting)
<b>Gauge Block :</b>	0 : Not mounted 1 : 6 bar (90 psi) 2 : 10 bar (150 psi)
<b>By-pass :</b>	N : None (standard) Y : Yes (auto/manual screw)

Description	Code
<b>Position Feedback :</b>	N : None O : Position transmitter (4~20mA output signal) L : 2 x alarm limit S : 2 x micro switch (SPDT) M : O + L Q : O + S
<b>Communication :</b>	N : None H : HART P : Profibus PA F : Foundation Fieldbus
<b>Connection Threads :</b> (pneumatic - electrical)	3 : PT(Rc) 1/4 - PF(G) 1/2 4 : NPT 1/4 - NPT 1/2 5 : PT(Rc) 1/4 - M20 x 1.5
<b>Mounting Bracket :</b>	N : None L : IEC 60534-6-1 (for SS2L) R : IEC 60534-6-2 (for SS2R) VDI/VDE 3845
<b>Feedback Pin Guide Lever Set :</b> (only for linear type SS2L)	0 : Not included 1 : Included



## Dimensions

### - SS2L (Linear Type)

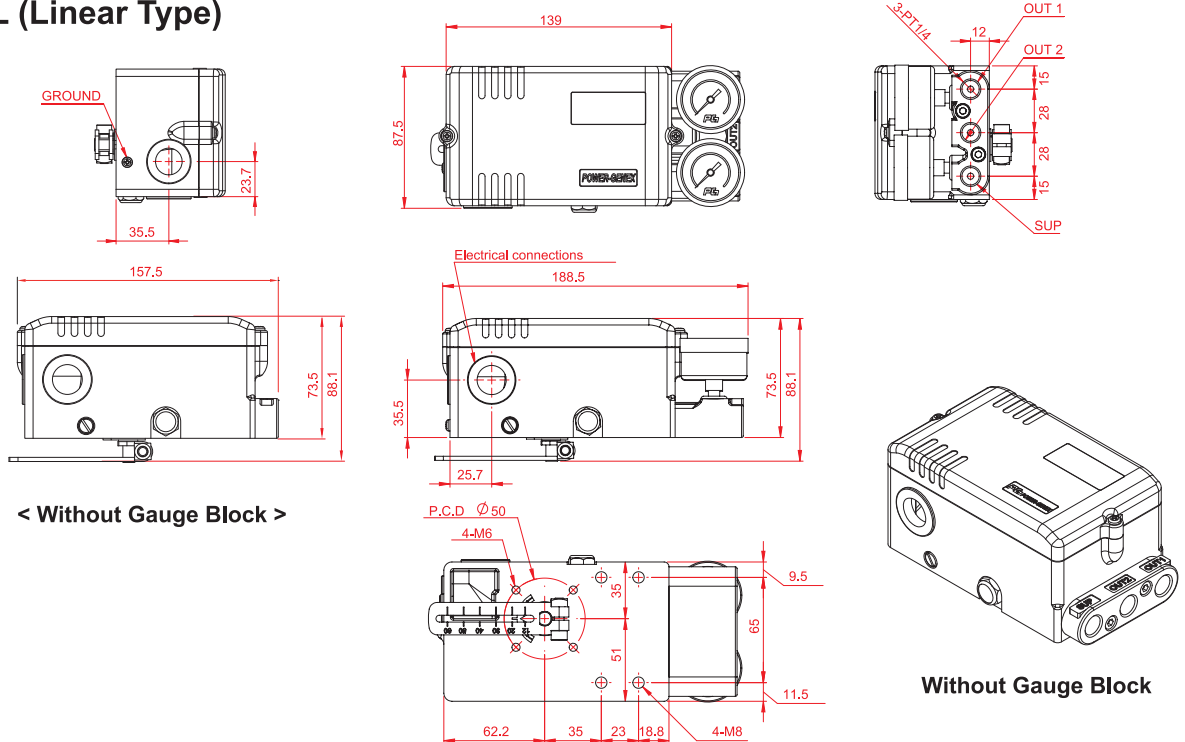

< Without Gauge Block >

Without Gauge Block

### - SS2R (Rotary Type)

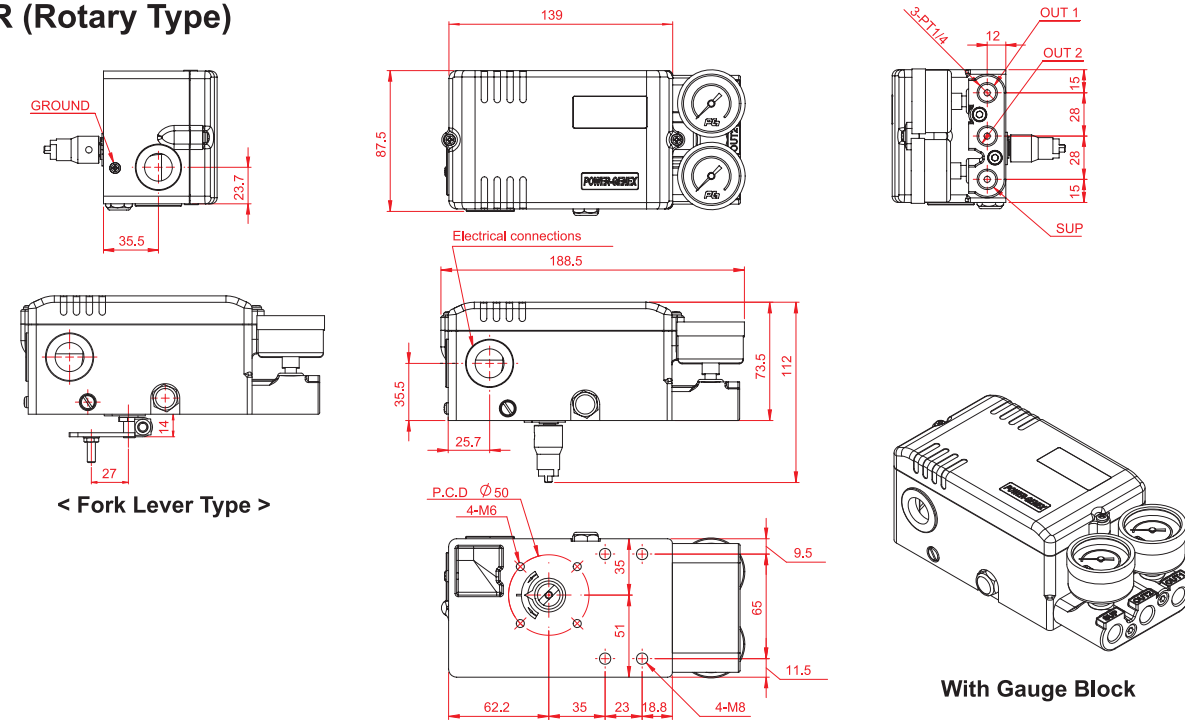

< Fork Lever Type >

With Gauge Block

### - SS2 with 2 x SPDT Micro S/W

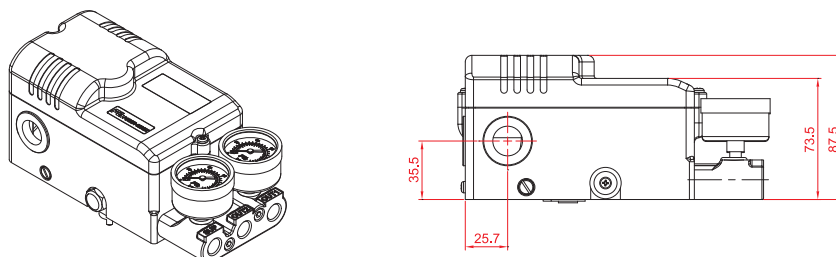

# Smart Valve Positioner ( remote type )

# SS2 Linear / Rotary

## How to Order

# SS2

Actuator Operation	Protection Class	Feedback Lever	Pressure Gauges	By-pass	Position Feedback	Communi-cation	Connection Threads	Mounting Bracket	Feedback Pin Guide Lever Set	Cable Length
--------------------	------------------	----------------	-----------------	---------	-------------------	----------------	--------------------	------------------	------------------------------	--------------

Description	Code
Cable Length :	3 : 3 m 5 : 5 m 10 : 10 m 15 : 15 m * Other on request

\* Please see "How to Order" on page 13 to select more options.

## Dimensions

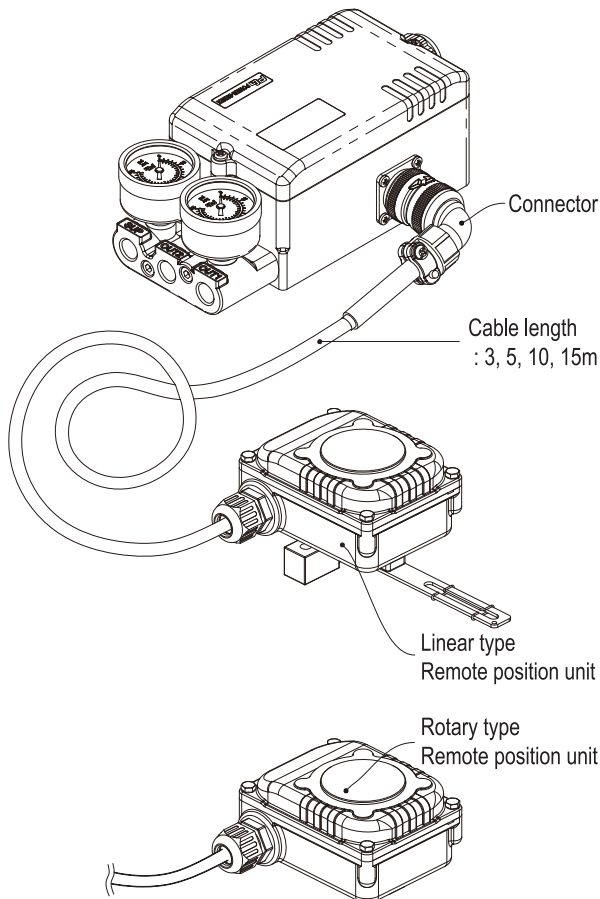

### < Linear Type Remote Position Unit >

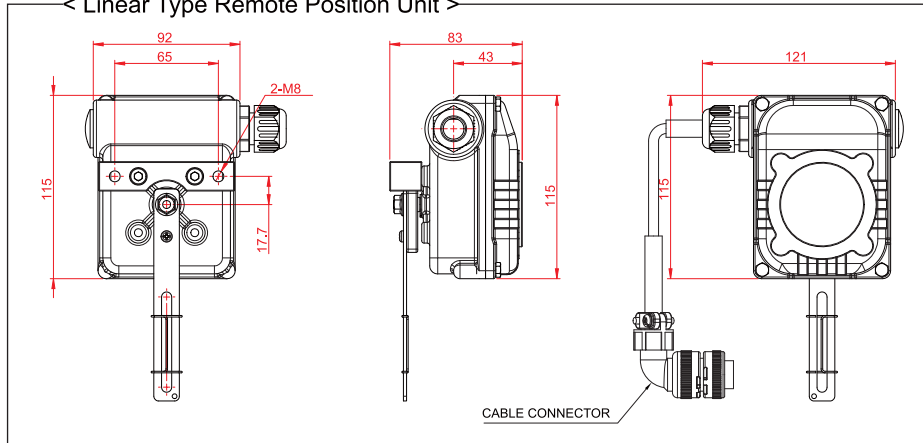

### < Rotary Type Remote Position Unit >

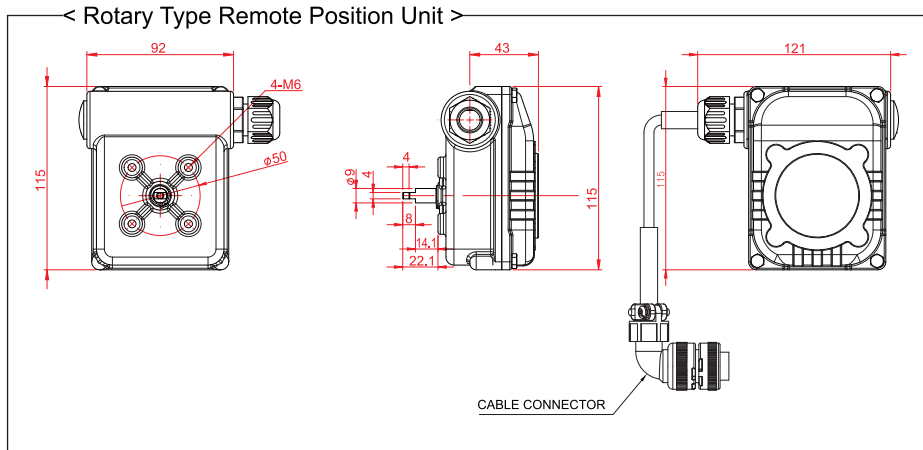

## Specifications



< SS2SL & SS2SR >



Communication	Without	HART	Profibus-PA	Fieldbus
Input Signal	4 - 20 mA @ 24 VDC		9 - 32 VDC	
Min. / Max. Current	3.6 mA / 50 mA		-	
Current Consumption	-		15mA	16mA
Voltage Drop (Resistance)	8.7 VDC(435Ω)	9.4 VDC(470Ω)		
Stroke / Angle	Linear type : 5 - 130 mm * Rotary type : 25 - 120°			
Air Supply Pressure	1.4 - 7.0 bar (20 - 100 psi)			
Output Pressure Range	0 - 100% of supply air pressure			
Air Capacity	80 ℓ/min = 4.8 N <sup>m</sup> /h = 2.8 scfm (Sup = 1.4 bar) 233 ℓ/min = 14 N <sup>m</sup> /h = 8.2 scfm (Sup = 6 bar)			
Air Consumption	2.8 ℓ/min = 0.17 N <sup>m</sup> /h = 0.1 scfm (Sup = 1.4 ~ 6 bar)			
Characteristic	Linearity < ±0.3% F.S Hysteresis < 0.2% F.S		Sensitivity < 0.2% F.S Repeatability < 0.2% F.S	
Performance Characteristic	Linear, EQ %, Quick open, User set (17 points)			
LCD Indication	4-digit LCD indicator			
Adjustable Speed	1 - 1000 (lowest 1, highest 1000)			
Scan Time	2ms			
Shut-off Value	Range 0 - 10% of position signal			
Valve Action	Direct action(DA) / Reverse action(RA)			
Operating Temperature	- 30 ~ +80 °C (- 22 ~ +176 °F) **			
Pneumatic Connections	NPT 1/4 (other on request)			
Electrical Connections	NPT 1/2 (other on request)			
Protection Class	IP66, Intrinsically safe (IECEx / ATEX / KC Exia IIC T6/T5)			
Body Material	Stainless steel 316			
Weight	3.8 kg (without bracket)			

## How to Order

\* Up to 200mm on request      \*\* -40 °C on request

**SS2S**    Actuator Operation    Protection Class    Feedback Lever    Pressure Gauges    By-pass    Position Feedback    Communication    Connection Threads    Mounting Bracket    Feedback Pin Guide Lever Set

Description	Code
<b>Actuator Operation :</b>	L : Linear type R : Rotary type
<b>Protection Class :</b>	I : Intrinsically safe IECEx / ATEX / TR-CU Ex ia IIC T6/T5 K : Intrinsically safe KC - Ex ia IIC T6/T5 W : Weatherproof to IP66
<b>Feedback Lever :</b>	
- Linear type :	A : Stroke (5~30mm) B : Stroke (5~65mm) C : Stroke (5~130mm) D : Stroke (80~200mm)
- Rotary type :	F : Fork lever N : NAMUR shaft (direct mounting)
<b>Gauge Block :</b>	0 : Not mounted 1 : 6 bar (90 psi) 2 : 10 bar (150 psi)
<b>By-pass :</b>	N : None Y : Yes (auto/manual screw)

Description	Code
<b>Position Feedback :</b>	N : None O : Position transmitter (4~20mA output signal) L : 2 x alarm limit S : 2 x micro switch (SPDT) M : O + L Q : O + S
<b>Communication :</b>	N : None H : HART P : Profibus PA F : Fieldbus Foundation
<b>Connection Threads :</b> (pneumatic - electrical)	4 : NPT 1/4 - NPT 1/2
<b>Mounting Bracket :</b>	N : None L : IEC 60534-6-1 (for SS2SL) R : IEC 60534-6-2 (for SS2SR) VDI/VE 3845
<b>Feedback Pin Guide Lever Set :</b> (only for linear type SS2SL)	0 : Not included 1 : Included

# Smart Valve Positioner

( Linear Sensor Positioner for Cylinder )

# SS2 Linear / Rotary



< Cylinder type >



< Angle Seat Valve type >



## Specifications

Communication	Without	HART	Profibus-PA	Fieldbus
Input Signal	4 - 20 mA @ 24 VDC		9 - 32 VDC	
Min. / Max. Current	3.6 mA / 50 mA		-	
Current Consumption	-		15mA	16mA
Voltage Drop (Resistance)	8.9 VDC(445Ω)	9.4 VDC(470Ω)		
Stroke	Up to 1000 mm			
Air Supply Pressure	1.4 - 7.0 bar (20 - 100 psi)			
Output Pressure Range	0 - 100% of supply air pressure			
Air Capacity	80 l/min = 4.8 N <sup>m</sup> /h = 2.8 scfm (Sup = 1.4 bar) 233 l/min = 14 N <sup>m</sup> /h = 8.2 scfm (Sup = 6 bar)			
Air Consumption	2 l/min = 0.12 N <sup>m</sup> /h = 0.07 scfm (Sup = 1.4 ~ 6 bar)			
Characteristic	Linearity $\pm 0.3\%$ F.S Hysteresis $< 0.2\%$ F.S		Sensitivity $< 0.2\%$ F.S Repeatability $< 0.2\%$ F.S	
Performance Characteristic	Linear, EQ %, Quick open, User set (17 points)			
LCD Indication	4-digit LCD indicator			
Adjustable Speed	1 - 1000 (lowest 1, highest 1000)			
Scan Time	2ms			
Shut-off Value	Range 0 - 10% of position signal			
Valve Action	Direct action(DA) / Reverse action(RA)			
Operating Temperature	- 30 ~ +80°C (- 22 ~ +176 °F) *			
Pneumatic Connections	PT(Rc) 1/4, NPT 1/4			
Electrical Connections	2 x PF(G) 1/2, NPT 1/2, M20 x 1.5			
Protection Class	IP66, Intrinsically safe (IECEX / ATEX / KC Ex ia IIC T6/T5)			
Body Material	Aluminum die-cast / power-painted			
Weight	1.6 kg (without bracket & sensor)			

\* - 40°C on request

## How to Order

# SS2C

Protection Class	Cylinder Stroke	Pressure Gauges	By-pass	Position Feedback	Communication	Connection Threads	Mounting Bracket	Cable Length
------------------	-----------------	-----------------	---------	-------------------	---------------	--------------------	------------------	--------------

Description	Code
<b>Protection Class :</b>	I : Intrinsically safe IECEX / ATEX / TR-CU Ex ia IIC T6/T5 K : Intrinsically safe KC - Ex ia IIC T6/T5 W : Weatherproof to IP66
<b>Cylinder Stroke :</b>	A : Cylinder stroke 10 ~ 30mm B : Cylinder stroke 30 ~ 80mm C : Cylinder stroke 80 ~ 125mm D : Cylinder stroke 125 ~ 165mm E : Cylinder stroke 165 ~ 260mm F : Cylinder stroke 260 ~ 350mm x : Other on request
<b>Gauge Block :</b>	0 : Not mounted 1 : 6 bar (90 psi) 2 : 10 bar (150 psi)
<b>By-pass :</b>	N : None Y : Yes (auto/manual screw)

Description	Code
<b>Position Feedback :</b>	N : None O : Position transmitter (4~20mA output signal) L : 2 x alarm limit M : O + L
<b>Communication :</b>	N : None H : HART P : Profibus PA F : Foundation Fieldbus
<b>Connection Threads :</b> (pneumatic - electrical)	3 : PT(Rc) 1/4 - PF 1/2 4 : NPT 1/4 - NPT 1/2 5 : PT(Rc) 1/4 - M20 x 1.5
<b>Mounting Bracket :</b>	N : None Actuator Model NO.
<b>Cable Length :</b>	Standard, 3, 5, 10, 15m Other : On request

## Dimensions

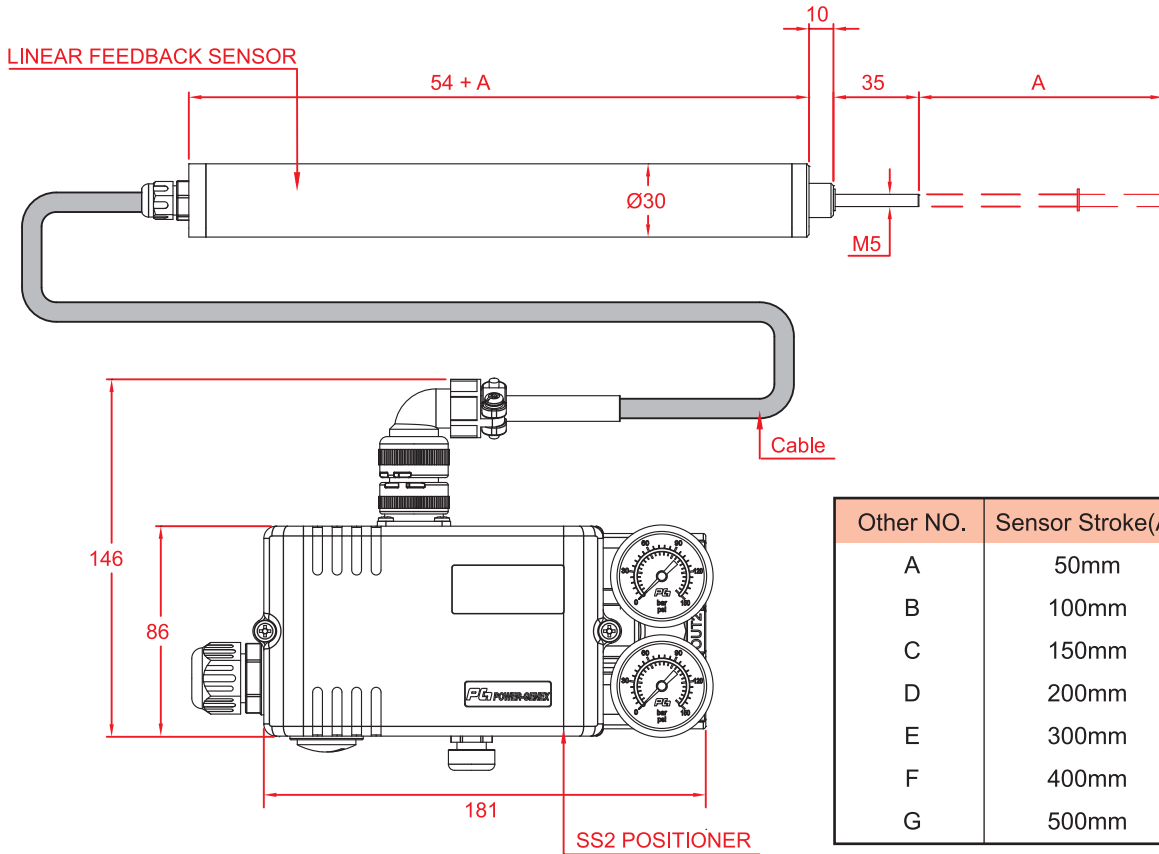

Other NO.	Sensor Stroke(A)	Stroke
A	50mm	10 ~ 30mm
B	100mm	30 ~ 80mm
C	150mm	80 ~ 125mm
D	200mm	125 ~ 165mm
E	300mm	165 ~ 260mm
F	400mm	260 ~ 350mm
G	500mm	350 ~ 440mm

## Applications

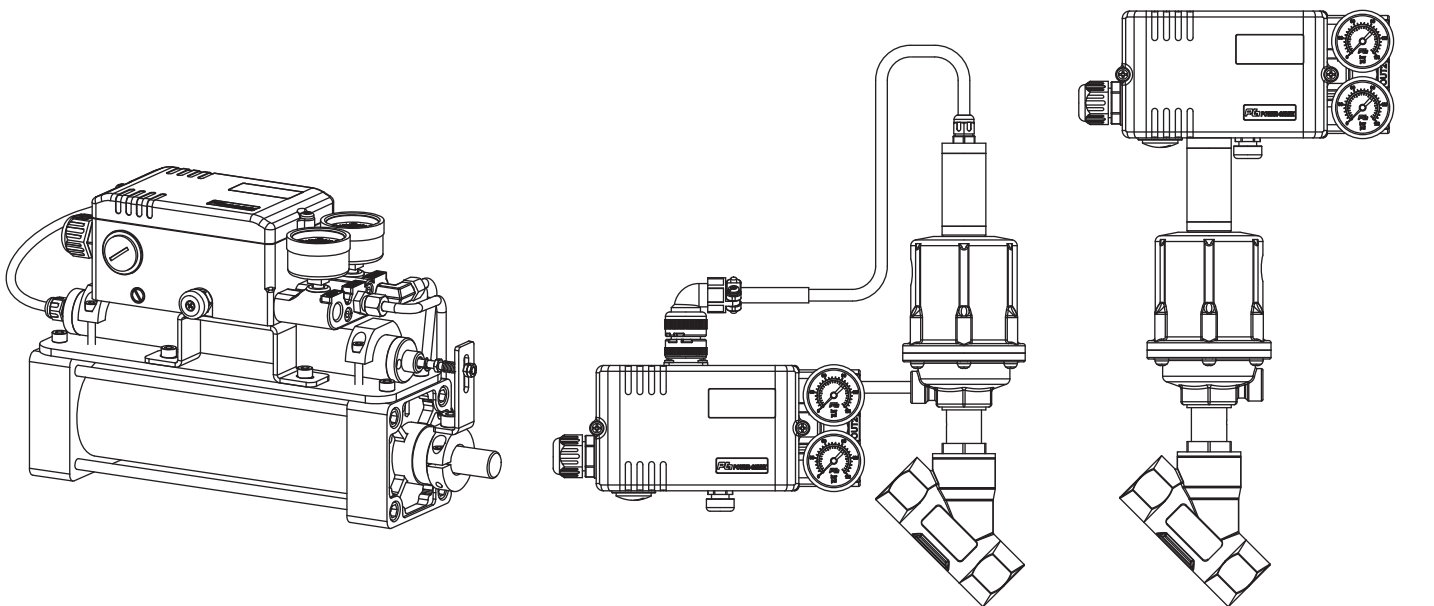

< Cylinder Mounting >

< Remote Mounting >

< Angle Seat Valve Mounting >



**Sturdy explosion proof housing and smart performance with innovative and ever-strong coil drive even under harsh working environments**

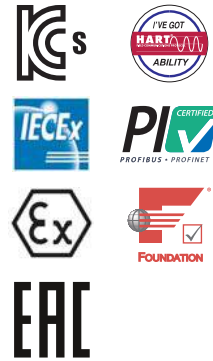

## Features

- ▶ Flameproof IECEx / ATEX / TR-CU / KC Ex d IIC T6
- ▶ Easy and quick auto-calibration
- ▶ Detecting RA (reverse acting) or DA (direct acting) automatically regardless of wrong air connections
- ▶ Available to use for single or double acting without any special adjustments
- ▶ Compact design allowing to be installed on small actuators
- ▶ Providing error messages against performance failures
- ▶ Possible to test the actuator with any fixed signal under a test mode
- ▶ Programmable characteristic curve with 17 points
- ▶ Wide operating temperature range -30 ~ +75 °C
- ▶ Improved control of high-friction globe and ball valves by eliminating an overshoot and a hunting
- ▶ Low air consumption
- ▶ Providing a mounting bracket to meet IEC 60534-6-1 for linear valves
- ▶ Supporting a NAMUR mounting pattern IEC 60534-6-2 (VDI/VDE 3845) and providing a multi-size mounting bracket for rotary valves

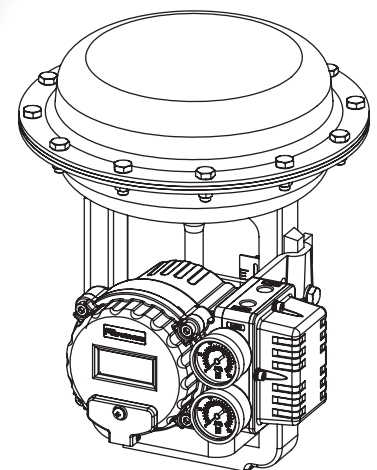

**- SS3L (Linear Type)**

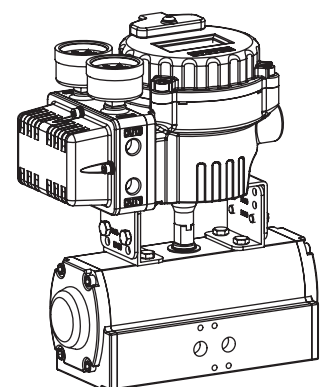

**- SS3R (Rotary Type)**

## Options

- ▶ Output position transmitter (4 - 20 mA)
- ▶ 2 x alarm limit
- ▶ Low temperature (-40°C)
- ▶ HART communication
- ▶ Profibus PA communication
- ▶ Foundation Fieldbus communication

## Specifications

Communication	Without	HART	Profibus - PA	Foundation Fieldbus
Input Signal / Bus voltage	4 - 20 mA @ 24 VDC		9 - 32 VDC	
Min. / Max. Current	3.6 mA / 50 mA		-	
Current Consumption	-		15mA	16mA
Voltage Drop (Resistance)	8.7 VDC(435Ω)	9.4 VDC(470Ω)	-	
Stroke / Angle	Linear type : 5 - 130 mm * Rotary type : 25 - 120°			
Air Supply Pressure	1.4 - 7.0 bar ( 20 - 100 psi ), filtered, compressed dry and non-oiled to meet Class 3 of ISO 8573-1			
Output Pressure Range	0 - 100% of supply air pressure			
Air Capacity	80 ℓ/min = 4.8 N <sup>m</sup> /h = 2.8 scfm (Sup = 1.4 bar) 233 ℓ/min = 14 N <sup>m</sup> /h = 8.2 scfm (Sup = 6 bar)			
Air Consumption	2.8 ℓ/min = 0.17 N <sup>m</sup> /h = 0.1 scfm (Sup = 1.4 ~ 6 bar)			
Characteristic	Linearity < ±0.3% F.S Hysteresis < 0.2% F.S		Sensitivity < 0.2% F.S Repeatability < 0.2% F.S	
Performance Characteristic	Linear, EQ %, Quick open, User set (17 points)			
LCD Indication	4-digit LCD indicator			
Adjustable Speed	1 - 1000 (lowest 1, highest 1000)			
Scan Time	2ms			
Shut-off Value	Range 0 - 10% of position signal			
Valve Action	direct action (DA) / reverse action (RA)			
Operating Temperature	- 30 ~ +75 °C (- 22 ~ +167 °F) **			
Pneumatic Connections	PT(Rc) 1/4 or NPT 1/4			
Electrical Connections	2 x PF(G) 1/2 , NPT 1/2 , M20 x 1.5			
Protection Class	Flameproof IECEx / ATEX / KC Ex d IIC T6, IP66			
Body Material	Aluminum die-cast / powder-painted			
Weight	2.8 kg			

\* Up to 200mm on request    \*\* -40 °C on request

## Principle of Operation

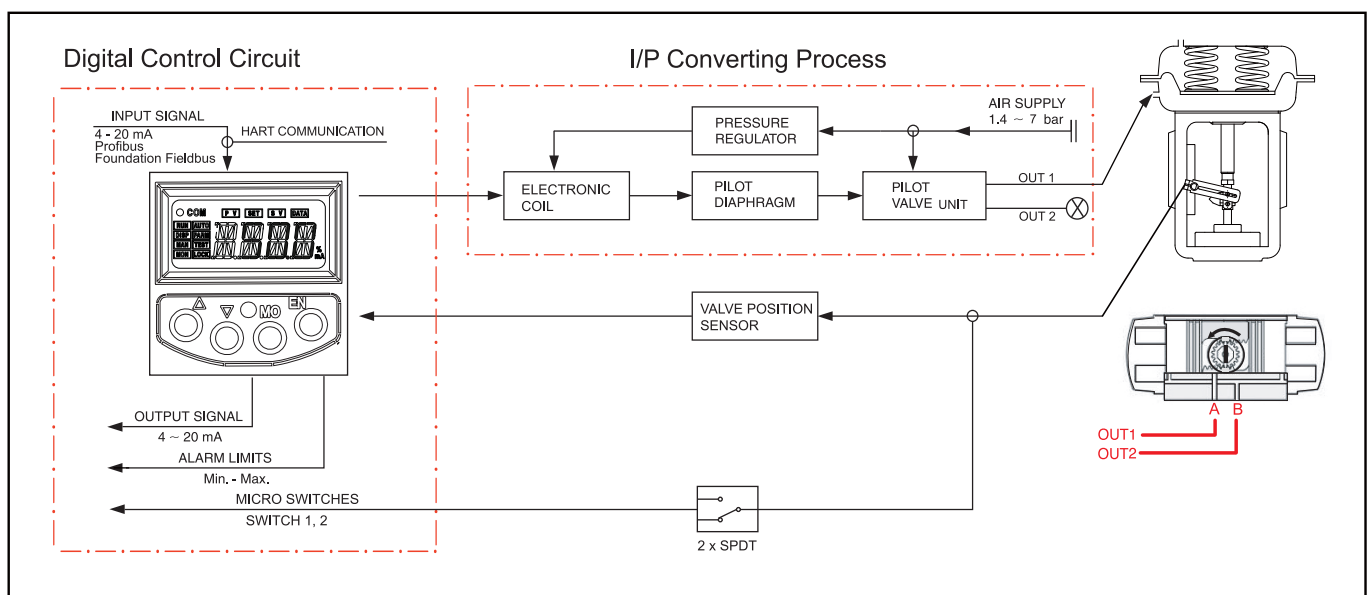

If 4-20 mA input signal(or Bus communication signal) is supplied, the micro processor compares input signal with position feedback and sends control signal to the I/P converting module. Pneumatic signal from the I/P converting module operates the valve and the valve stays at the desired position.

## Mounting to Linear Actuator

### - SS3L (Linear Type)

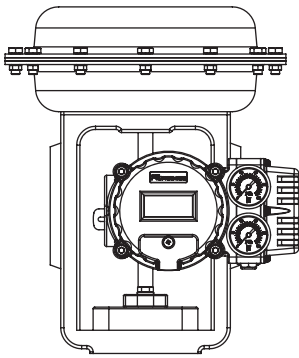

< Front View >

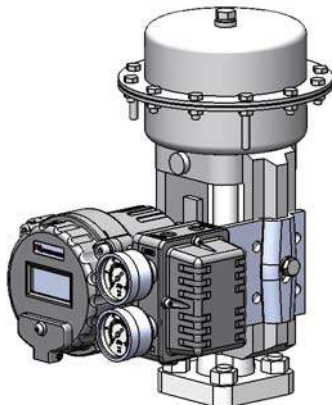

< Side View >

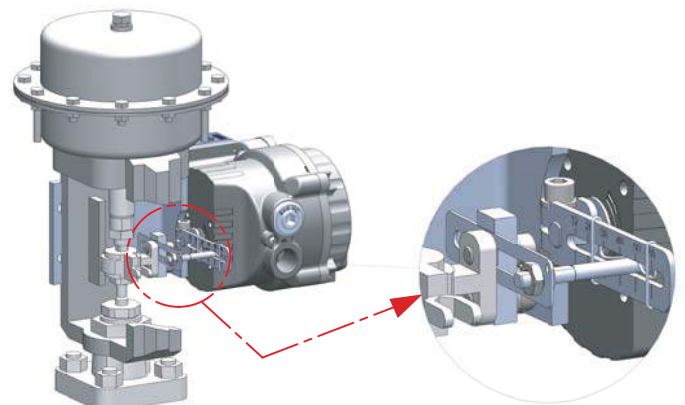

< Feedback Lever Connection >

#### "A" Type

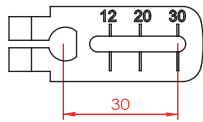

#### "B" Type

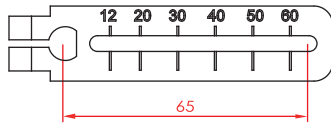

#### "C" Type

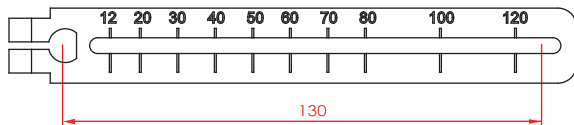

Feedback Lever

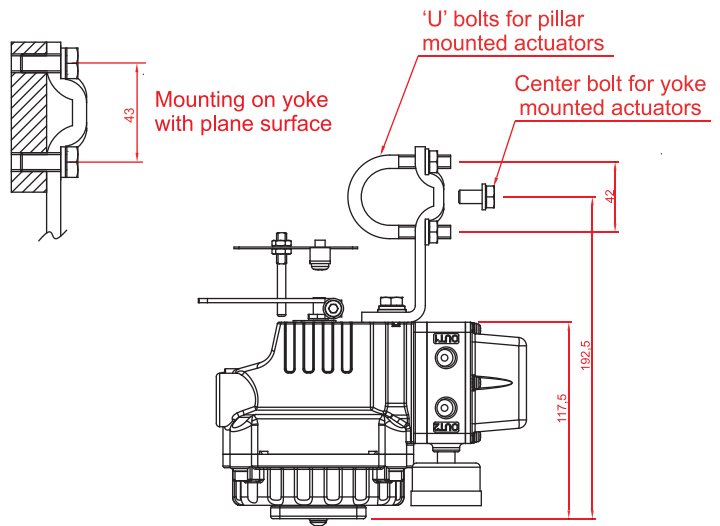

Mounting to linear actuators to IEC 60534 6-1

## Mounting to Rotary Actuator

### - SS3R (Rotary Type)

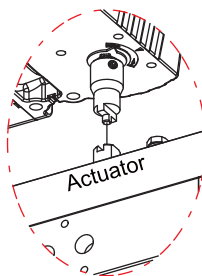
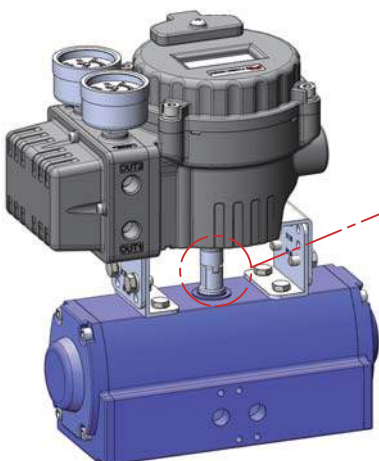

**NAMUR Type Mounting**  
( VDI/VDE 3845,  
IEC 60534-6-2 )

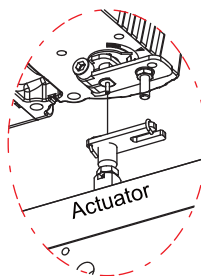

**Fork Lever Type Mounting**

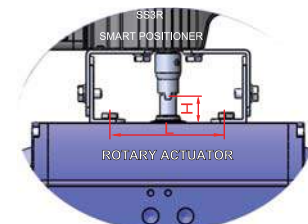

#### Size Variation of Multi-Size Bracket

- 1) 80 x 30 x 20 (H) , 4) 130 x 30 x 20 (H)
- 2) 80 x 30 x 30 (H) , 5) 130 x 30 x 30 (H)
- 3) 80 x 30 x 50 (H) , 6) 130 x 30 x 50 (H)

H : Rotary Actuator Shaft Height  
L : Length ( 80 or 130mm )

## Air Connections

### - SS3L (Linear Type)

Direct Acting (DA)		Reverse Acting (RA)	
<p><b>DA 1</b></p> <p>As the input signal increases, Valve stem moves downwards Actuator : DA</p>	<p>OUT2 must be plugged</p>	<p><b>RA 1</b></p> <p>As the input signal increases, Valve stem moves upwards Actuator : RA</p>	<p>OUT2 must be plugged</p>
<p><b>DA 2</b></p> <p>As the input signal increases, Valve stem moves downwards Actuator : DA</p>	<p>OUT1 must be plugged</p>	<p><b>RA 2</b></p> <p>As the input signal increases, Valve stem moves upwards Actuator : RA</p>	<p>OUT1 must be plugged</p>
<p><b>DA 3</b></p> <p>As the input signal increases, Valve stem moves downwards</p>		<p><b>RA 3</b></p> <p>As the input signal increases, Valve stem moves upwards</p>	

### - SS3R (Rotary Type)

Spring Return	Double Acting	Double Acting
<p>Actuator : RA</p> <p>OUT2 must be plugged</p>	<p>Actuator : RA</p>	<p>Actuator : DA</p>
<p>As the input signal increases, Actuator shaft rotates counter-clockwise</p>	<p>As the input signal increases, Actuator shaft rotates counter-clockwise</p>	<p>As the input signal increases, Actuator shaft rotates clockwise</p>

	Spring Return	Double Acting
Reverse Acting	Out 1 : piped, Out 2 : plugged	Out 1 : piped to Actuator port A, Out 2 : piped to Actuator port B
Direct Acting	Out 1 : plugged, Out 2 : piped	Out 1 : piped to Actuator port B, Out 2 : piped to Actuator port A

## SS3 Front Cover Removed

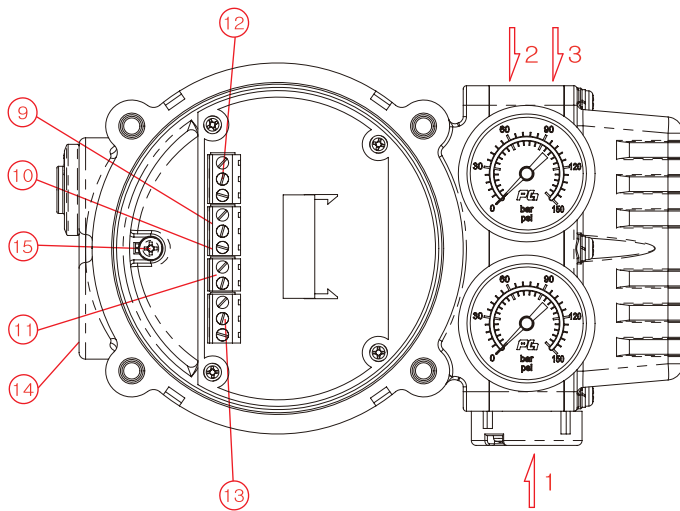

## SS3 Front Cover

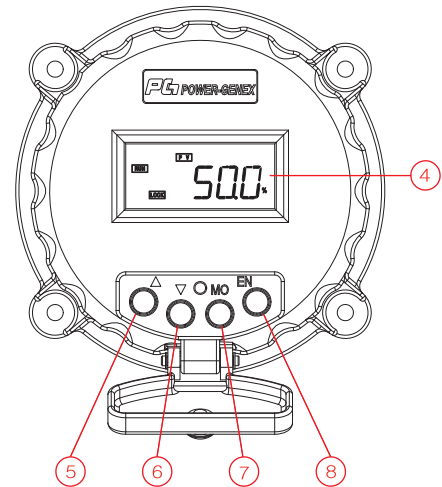

- |                 |               |                           |                             |
|-----------------|---------------|---------------------------|-----------------------------|
| 1 : Air supply  | 5 : Up key    | 9 : Input signal (+, -)   | 13 : Alarm limit            |
| 2 : OUT 1       | 6 : Down key  | 10 : Frame ground         | 14 : Electrical connections |
| 3 : OUT 2       | 7 : Mode key  | 11 : Output signal (+, -) | 15 : Ground                 |
| 4 : Display LCD | 8 : Enter key | 12 : Alarm limit          | 16 : Feedback lever         |

## Electrical Connections

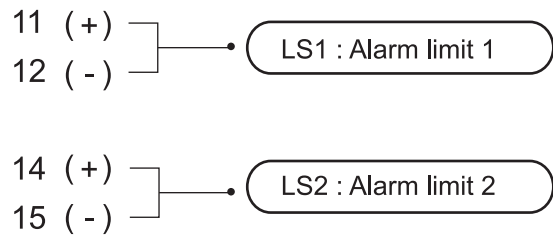
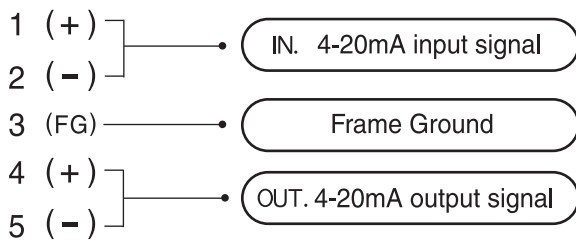

## Characteristic Curves

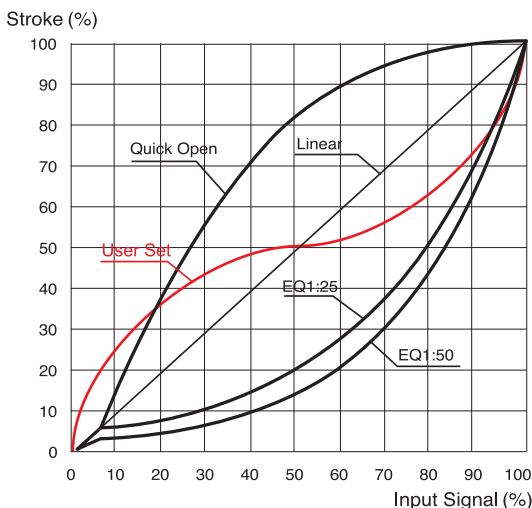

## Quick Start and Checking

	Button	Action
Auto - Calibration	MO	Push 5 seconds for auto-calibration
Span	VDN → ENT VDN or ΔUP ENT → MO	Push VDN 5 seconds to change a measured span (Try this option only when a valve doesn't reach a desired position)
Ambient Temp.	ENT	Confirm an ambient temperature surrounding this smart valve positioner



## Parameters Diagram

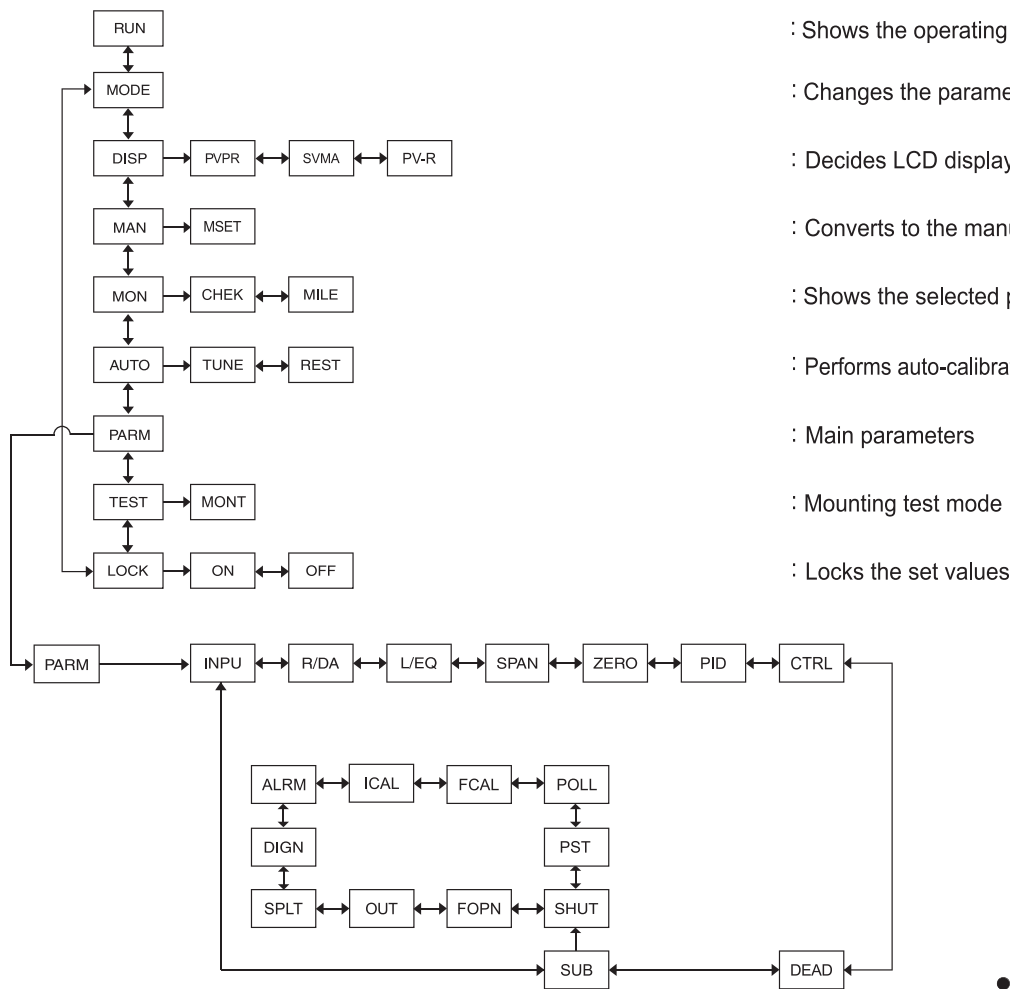

- : Shows the operating situation of the positioner
- : Changes the parameters
- : Decides LCD display mode in mA, % or a reverse way
- : Converts to the manual mode
- : Shows the selected parameters and a total valve runtime
- : Performs auto-calibration and resets all programmed values
- : Main parameters
- : Mounting test mode
- : Locks the set values

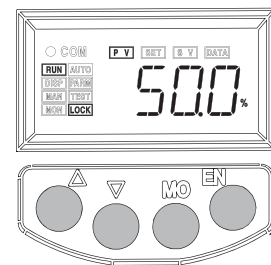

**LCD Display**

● COM : Hart Communication

Parameter	Description	Fcution	Default
INPU	Input signal	4 ~ 20mA or 20 ~ 4mA	4 ~ 20mA
R/DA	RA/DA	Reverse acting or direct acting	Auto-set
L/EQ	Characteristic	Linear, E.Q.%(1:25 or 1:50), Quick open or User set(17points)	Linear
SPAN	Span adjustment	0 ~ 100%	100%
ZERO	Zero adjustment	0 ~ 99%	0%
PID	P-GN / I-GN / D-GN	Proportional / Integral / Differential gain value	Auto-set
SPED	Response speed	1 ~ 1000	1000
SWST	Slow start	Smooth operation (ON or OFF)	Auto-set
CNLT	Control limit	50 ~ 1250	Auto-set
GCNL	Gap control limit	50 ~ 1250	Auto-set
DEAD	Dead band	0 ~ 9.99%	0.5%
FDGN	D-gain setting for hard mode	D-Gain setting for hard mode	Auto-set
C/MD	NORM / HARD / SMAL	Standard actuator, strong valve packing friction, small actuator	NORM
SHUT	Shut-off	0 ~ 9.9%	0.3%
FOPN	Full-open	0 ~ 9.9%	0.3%
OUT	Output signal	4 ~ 20mA or 20 ~ 4mA	4 ~ 20mA
SPLT	Split range	4 ~ 12mA or 12 ~ 20mA	4 ~ 20mA
DIGN	Display place	Movement to one or two decimal places	1
ALAM	Alarm limit low, high	AL1L / AL1H / AL2L / AL2H	0 ~ 10%, 90 ~ 105%
ICAL	IN4M / IN20	Internal match with 4~20mA input signals from a calibrator	Factory setting
FCAL	FB4M / FB20	Internal match with 4~20mA output signals to a calibrator	Factory setting
POLL	Polling address	HART Communication polling address (0 ~ 15)	0
PST	Partial stroke test	Checks a valve status	OFF

## Wiring Alarm Limits

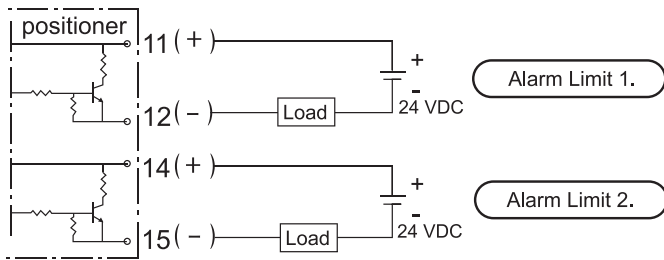

Note that 24 VDC should be supplied for power.

## Micro Switches (SPDT)

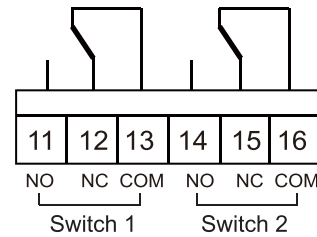

## Measuring Output Signal

① With mA loop calibrator

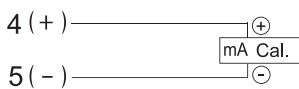

② With multimeter (mA)

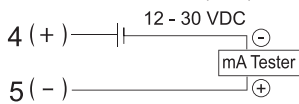

ZERO and SPAN of position feedback are automatically set after auto-calibration process.

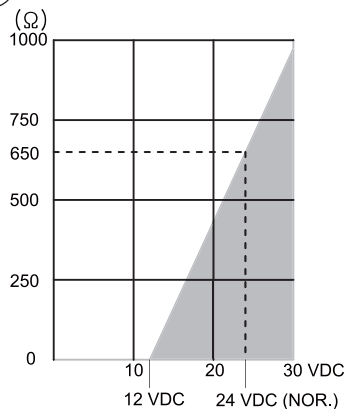

< Transmitter Load Limitations >

### Position Transmitter

Output Signal	4 - 20 mA, 2-wire
Power Supply	12 - 30 VDC
Output Current Limit	30 mA DC
Linearity	1% F.S
Operating Temp.	-30 ~ +80 °C

## How to Order

# SS3

- Actuator Operation
- Protection Class
- Feedback Lever
- Pressure Gauges
- By-pass
- Position Feedback
- Communication
- Connection Threads
- Mounting Bracket
- Feedback Pin Guide Lever Set

Description	Code
<b>Actuator Operation :</b>	L : Linear type R : Rotary type
<b>Protection Class :</b>	F : Flameproof IECEX / ATEX / TR-CU Ex d IIC T6 K : Flameproof KC - Ex d IIC T6
<b>Feedback Lever :</b>	
- Linear type :	A : Stroke (5~30mm) B : Stroke (5~65mm) C : Stroke (5~130mm) D : Stroke (80~200mm)
- Rotary type :	F : Fork lever N : NAMUR shaft (direct mounting)
<b>Gauge Block :</b>	0 : Not mounted 1 : 6 bar (90 psi) 2 : 10 bar (150 psi)
<b>By-pass :</b>	N : None (standard) Y : Yes (auto/manual screw)

Description	Code
<b>Position Feedback :</b>	N : None O : Position transmitter (4~20mA output signal) L : 2 x alarm limit S : 2 x SPDT (only for rotary type) M : O + L Q : O + S (only for rotary type)
<b>Communication :</b>	N : None H : HART P : Profibus PA F : Foundation Fieldbus
<b>Connection Threads :</b> (pneumatic - electrical)	3 : PT(Rc) 1/4 - PF(G) 1/2 4 : NPT 1/4 - NPT 1/2 5 : PT(Rc) 1/4 - M20 x 1.5
<b>Mounting Bracket :</b>	N : None L : IEC 60534-6-1 (for SS3L) R : IEC 60534-6-2 (for SS3R) VDI/VDE 3845
<b>Feedback Pin Guide Lever Set :</b> (only for linear type SS3L)	0 : Not included 1 : Included

## Dimensions

### - SS3L (Linear Type)

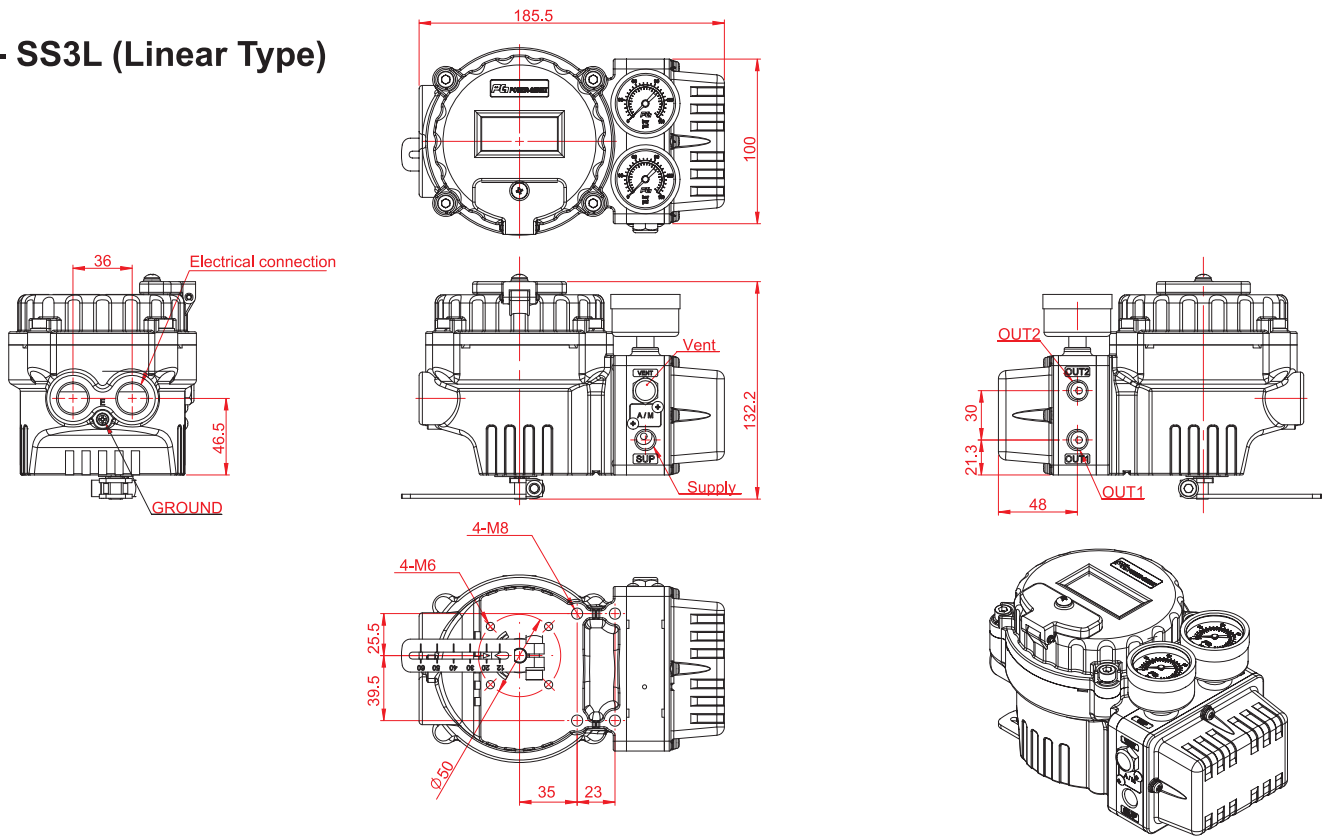

### - SS3R (Rotary Type)

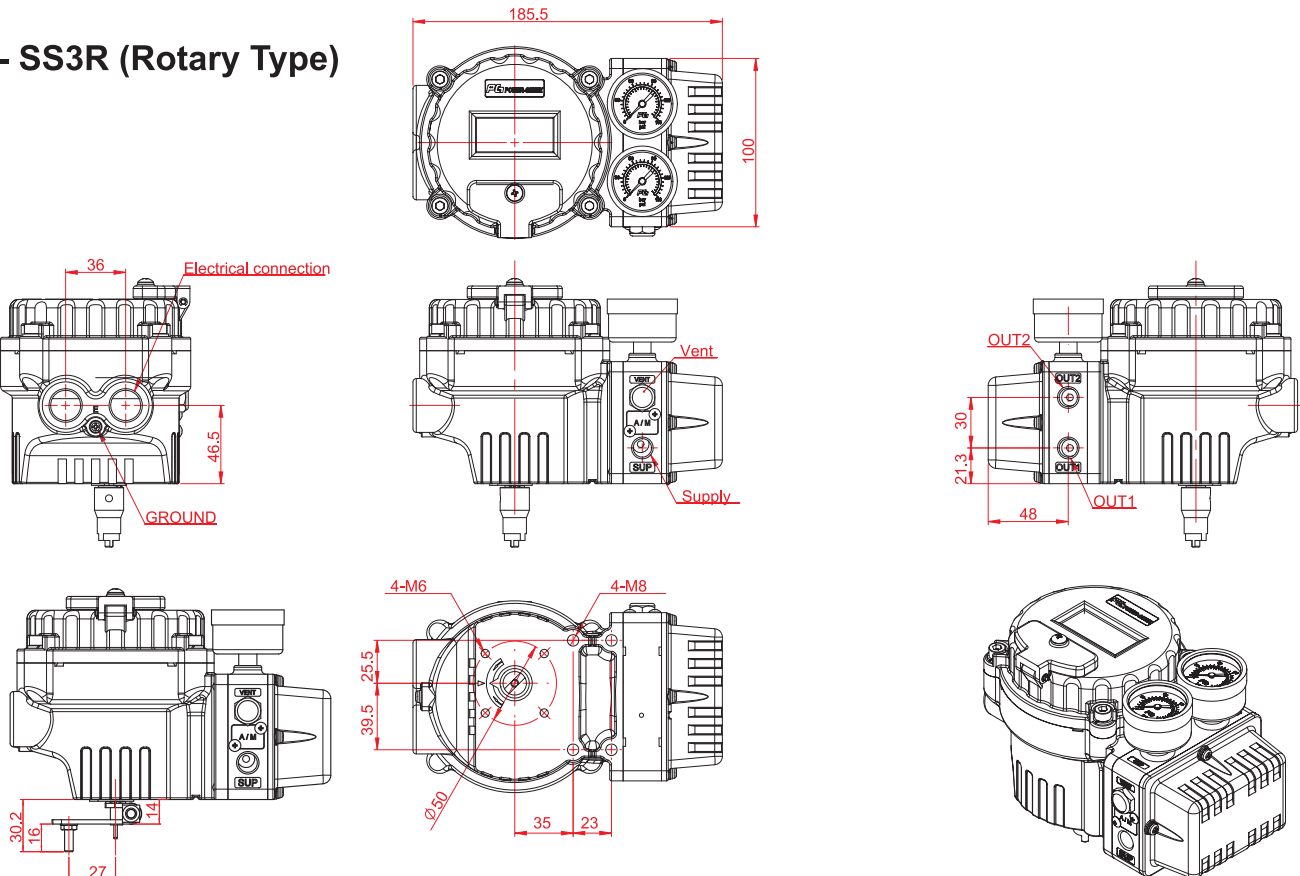

< Fork Lever Type >

# Smart Valve Positioner

( stainless steel 316 body )

# SS3S Linear / Rotary

## Specifications

Communication	Without	HART	Profibus-PA	Fieldbus
Input Signal	4 - 20 mA @ 24 VDC		9 - 32 VDC	
Min. / Max. Current	3.6 mA / 50 mA		-	
Current Consumption	-		15mA	16mA
Voltage Drop (Resistance)	8.7 VDC(435Ω)	9.4 VDC(470Ω)		
Stroke / Angle	Linear type : 5 - 130 mm * Rotary type : 25 - 120°			
Air Supply Pressure	1.4 - 7.0 bar (20 - 100 psi)			
Output Pressure Range	0 - 100% of supply air pressure			
Air Capacity	80 ℓ/min = 4.8 N <sup>m</sup> /h = 2.8 scfm (Sup = 1.4 bar) 233 ℓ/min = 14 N <sup>m</sup> /h = 8.2 scfm (Sup = 6 bar)			
Air Consumption	2.8 ℓ/min = 0.17 N <sup>m</sup> /h = 0.1 scfm (Sup = 1.4 ~ 6 bar)			
Characteristic	Linearity < ±0.3% F.S Hysteresis < 0.2% F.S		Sensitivity < 0.2% F.S Repeatability < 0.2% F.S	
Performance Characteristic	Linear, EQ %, Quick open, User set (17 points)			
LCD Indication	4-digit LCD indicator			
Adjustable Speed	1 - 1000 (lowest 1, highest 1000)			
Scan Time	2ms			
Shut-off Value	Range 0 - 10% of position signal			
Valve Action	Direct action(DA) / Reverse action(RA)			
Operating Temperature	- 30 ~ +75 °C (- 22 ~ +167 °F) **			
Pneumatic Connections	NPT 1/4 (other on request)			
Electrical Connections	NPT 1/2 (other on request)			
Protection Class	Flameproof (IECEX / ATEX / KC Ex d IIC T6)			
Body Material	Stainless steel 316			
Weight	6.5 kg (without bracket)			



< SS3SL & SS3SR >



## How to Order

\* Up to 200mm on request    \*\* -40°C on request

**SS3S** [Actuator Operation] [Protection Class] [Feedback Lever] [Pressure Gauges] [By-pass] [Position Feedback] [Communication] [Connection Threads] [Mounting Bracket] [Feedback Pin Guide Lever Set]

Description	Code
<b>Actuator Operation :</b>	L : Linear type R : Rotary type
<b>Protection Class :</b>	F : Flameproof IECEX / ATEX / TR-CU Ex d IIC T6 K : Flameproof KC - Ex d IIC T6
<b>Feedback Lever :</b>	
- Linear type :	A : Stroke (5~30mm) B : Stroke (5~65mm) C : Stroke (5~130mm) D : Stroke (80~200mm)
- Rotary type :	F : Fork lever N : NAMUR shaft (direct mounting)
<b>Gauge Block :</b>	0 : Not mounted 1 : 6 bar (90 psi) 2 : 10 bar (150 psi)
<b>By-pass :</b>	N : None Y : Yes (auto/manual screw)

Description	Code
<b>Position Feedback :</b>	N : None O : Position transmitter (4~20mA output signal) L : 2 x alarm limit S : 2 x SPDT (only for rotary type) M : O + L Q : O + S (only for rotary type)
<b>Communication :</b>	N : None H : HART P : Profibus PA F : Fieldbus Foundation
<b>Connection Threads :</b> (pneumatic - electrical)	4 : NPT 1/4 - NPT 1/2
<b>Mounting Bracket :</b>	N : None L : IEC 60534-6-1 (for SS3SL) R : IEC 60534-6-2 (for SS3SR) VDI/DE 3845
<b>Feedback Pin Guide Lever Set :</b> (only for linear type SS3SL)	0 : Not included 1 : Included



< SS3L-IPC >



## Specifications

Communication	Without	HART	Profibus-PA	Fieldbus
Input Signal	4 - 20 mA @ 24 VDC		9 - 32 VDC	
Min. / Max. Current	3.6 mA / 50 mA		-	
Current Consumption	-		15mA	16mA
Voltage Drop (Resistance)	8.9 VDC(445Ω)	9.4 VDC(470Ω)		
Air Supply Pressure	1.4 - 7.0 bar (20 - 100 psi)			
Air Capacity	80 ℓ/min = 4.8 N <sup>m</sup> /h = 2.8 scfm (Sup = 1.4 bar) 233 ℓ/min = 14 N <sup>m</sup> /h = 8.2 scfm (Sup = 6 bar)			
Air Consumption	2 ℓ/min = 0.12 N <sup>m</sup> /h = 0.07 scfm (Sup = 1.4 ~ 6 bar)			
Characteristic	Linearity < ±0.3% F.S Hysteresis < 0.2% F.S		Sensitivity < 0.2% F.S Repeatability < 0.2% F.S	
Performance Characteristic	Linear			
LCD Indication	4-digit LCD indicator			
Scan Time	2ms			
Valve Action	Direct action(DA) / Reverse action(RA)			
Operating Temperature	- 30 ~ +75 °C (- 22 ~ +167 °F) *			
Pneumatic Connections	PT 1/4, NPT 1/4			
Electrical Connections	PF 1/2, NPT 1/2			
Protection Class	Flameproof (IECEX / ATEX / KC Ex d IIC T6)			
Body Material	Aluminum die-cast / Stainless steel 316			
Weight	2.8 kg			

\* -40 °C on request

## How to Order

# SS3



Description	Code
<b>Actuator Operation :</b>	L : Aluminum die-cast SL : Stainless steel 316
<b>Protection Class :</b>	F : Flameproof IECEX / ATEX / TR-CU Ex d IIC T6 K : Flameproof KC - Ex d IIC T6
<b>Feedback Lever :</b>	X : Not applicable
<b>Gauge Block :</b> (Supply pressure gauge)	1 : 6 bar (90 psi) 2 : 10 bar (150 psi)
<b>By-pass :</b>	N : None Y : Yes (auto/manual screw)

Description	Code
<b>Position Feedback :</b>	N : None O : Position transmitter (4~20mA output signal)
<b>Communication :</b>	N : None H : HART P : Profibus PA F : Fieldbus Foundation
<b>Connection Threads :</b> (pneumatic - electrical)	3 : PT 1/4 - PF 1/2 4 : NPT 1/4 - NPT 1/2
<b>Mounting Bracket :</b>	N : None
<b>Output Pressure :</b>	21 : 3...15 psi



**Perfect combination with reliable fail freeze function and smart performance with innovative durable coil drive**



## Features

- ▶ “Fail Freeze” function to help the valve stay at the last position on the electrical power supply or the pneumatic supply air by accident
- ▶ Easy and quick auto-calibration
- ▶ Detecting RA (reverse acting) or DA (direct acting) automatically regardless of wrong air connections
- ▶ Available to use for single or double acting without any special adjustments
- ▶ Compact design allowing to be installed on small actuators
- ▶ Providing error messages against performance failures
- ▶ Possible to test the actuator with any fixed signal under a test mode
- ▶ Programmable characteristic curve with 17 points
- ▶ Wide operating temperature range -30 ~ +80 °C
- ▶ Improved control of high-friction globe and ball valves by eliminating an overshoot and a hunting
- ▶ Low air consumption
- ▶ Providing a mounting bracket to meet IEC 60534-6-1 for linear valves
- ▶ Supporting a NAMUR mounting pattern VDI/VDE 3845 (IEC 60534-6-2) and providing a multi-size mounting bracket for rotary valves

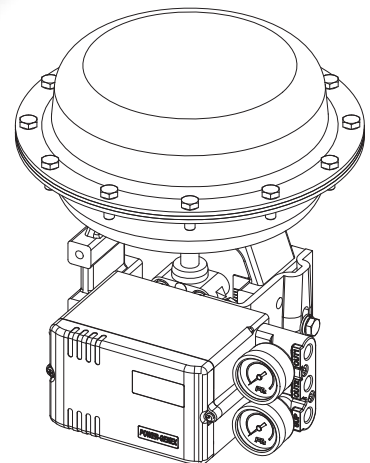

**- SS5L (Linear Type)**

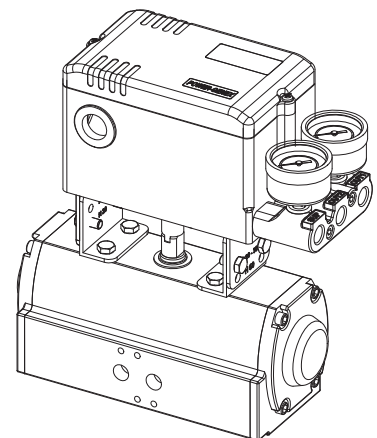

**- SS5R (Rotary Type)**

## Options

- ▶ Output position transmitter (4 - 20 mA)
- ▶ 2 x alarm limit or micro switch (SPDT)
- ▶ Explosion proof type (IECEx / ATEX / KC Ex ia IIC T6/T5 - in progress)
- ▶ HART communication
- ▶ Profibus communication (in progress)
- ▶ Fieldbus Foundation communication (in progress)



## Specifications

Input Signal	4 - 20 mA @ 24 VDC
Min. / Max. Current	3.6 mA / 50 mA
Voltage Drop (Resistance)	Without Hart : 8.9 VDC (445Ω @ 20 mA) With Hart : 9.4 VDC (470Ω @ 20 mA)
Stroke / Angle	Linear type : 5 - 130 mm * Rotary type : 25 - 120°
Air Supply Pressure	1.4 - 7 bar (20 - 100 psi), filtered, compressed dry and non-oiled to meet Class 3 of ISO 8573-1
Output Pressure Range	0 - 100% of supply air pressure
Air Capacity	80 ℓ/min = 4.8 N <sup>m</sup> /h = 2.8 scfm (Sup = 1.4 bar) 233 ℓ/min = 14 N <sup>m</sup> /h = 8.2 scfm (Sup = 6 bar)
Air Consumption	2 ℓ/min = 0.12 N <sup>m</sup> /h = 0.07 scfm (Sup = 1.4 ~ 6 bar)
Characteristic	Linearity < ±0.3% F.S      Sensitivity < 0.2% F.S Hysteresis < 0.2% F.S      Repeatability < 0.2% F.S
Performance Characteristic	Linear, EQ %, Quick open, User set (17 points)
LCD Indication	4-digit LCD indicator
Adjustable Speed	1 - 1000 (lowest 1, highest 1000)
Scan Time	2ms
Shut-off Value	Range 0 - 10% of position signal
Valve Action	Direct action (DA) / Reverse action (RA)
Operating Temperature	- 30 ~ +80 °C (- 22 ~ +176 °F) **
Pneumatic Connections	PT(Rc) 1/4 or NPT 1/4
Electrical Connections	2 x PF(G) 1/2, NPT 1/2, M20 x 1.5
Protection Class	IP66, intrinsically safe (IECEX / ATEX / KC Exia IIC T6/T5)
Body Material	Aluminum die-cast / powder-painted
Weight	1.6 kg

\* Up to 200mm on request      \*\* -40 °C on request

## Principle of Operation

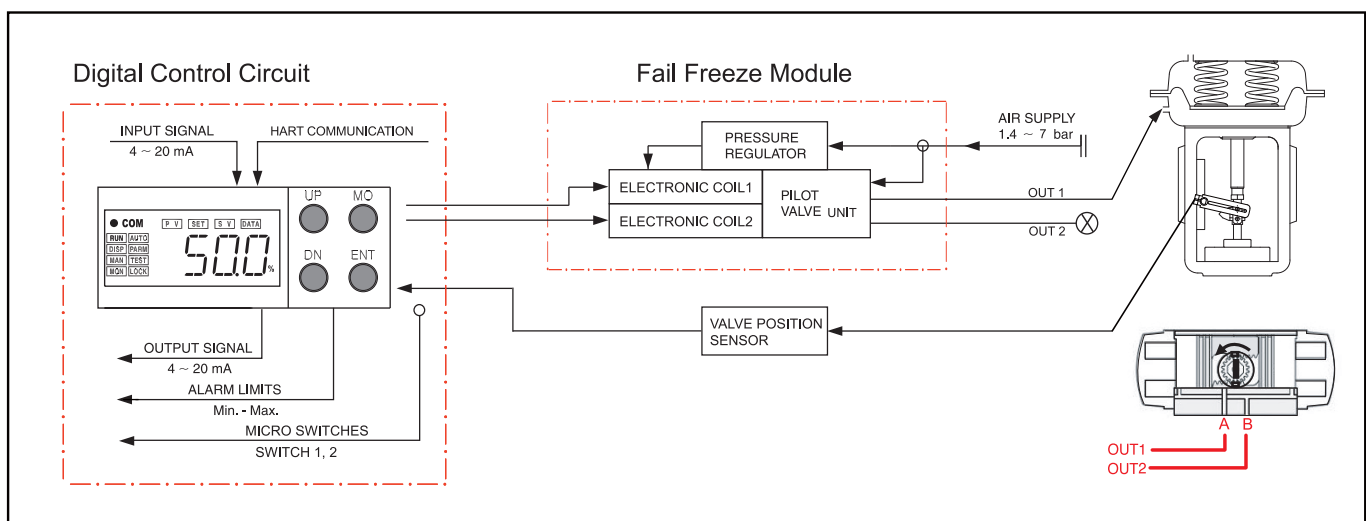

If 4-20mA input signal is supplied, the microprocessor compares the input signals and the feedback values and send the control signals to the I/P converter. A supply air is converted to the pneumatic signals by two electronic coils and moves the pilot valve until the control valve reaches the desired position. In case of a signal failure or a supply air failure, a venting air is blocked inside of the pilot valve and the valve stays at the last position because of an existing supply air pressure between the positioner and the actuator.

# Smart Valve Positioner ( fail freeze function )

# SS5 Linear / Rotary

## SS5 Front Cover Removed

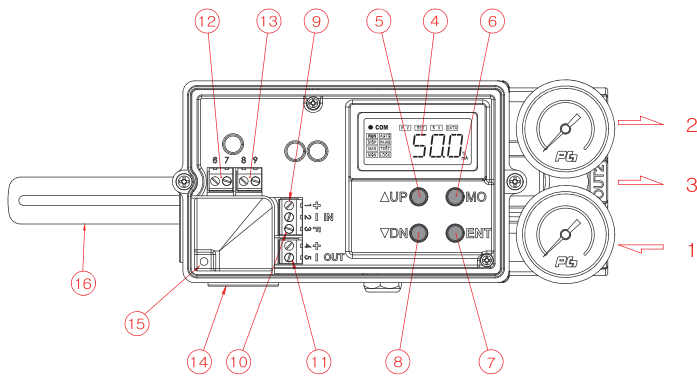

- 1 : Air supply
- 2 : OUT 1
- 3 : OUT 2
- 4 : Display LCD
- 5 : Up key
- 6 : Mode key
- 7 : Enter key
- 8 : Down key
- 9 : Input signal (+, -)
- 10 : Frame ground
- 11 : Output signal (+, -)
- 12 : Alarm limit 1
- 13 : Alarm limit 2
- 14 : Electrical connections
- 15 : Ground
- 16 : Feedback lever

## Electrical Connections

- 1 (+) — IN. 4-20mA input signal
- 2 (-) — Frame Ground
- 3 (FG) — Frame Ground
- 4 (+) — OUT. 4-20mA output signal
- 5 (-) — OUT. 4-20mA output signal
- 6 (+) — LS1. (Low) Alarm limit 1
- 7 (-) — LS1. (Low) Alarm limit 1
- 8 (+) — LS2. (High) Alarm limit 2
- 9 (-) — LS2. (High) Alarm limit 2

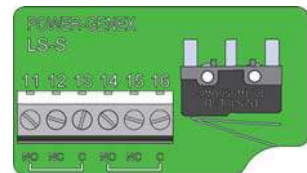
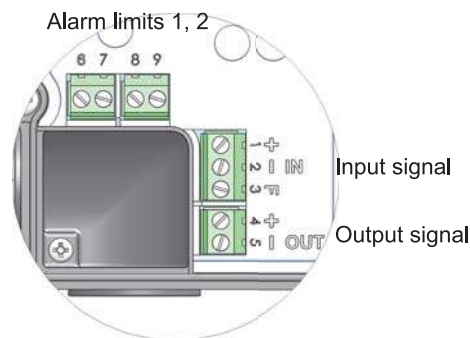

Micro switches 1, 2

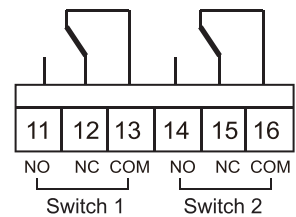

## How to Order

**SS5** Actuator Operation — Protection Class Feedback Lever Pressure Gauges Position Feedback Communication Connection Threads Mounting Bracket Feedback Pin Guide Lever Set

Description	Code
<b>Actuator Operation :</b>	L : Linear type R : Rotary type
<b>Protection Class :</b>	I : Intrinsically safe (IECEX Ex ia IIC T6/T5, ATEX Ex ia IIC T6/T5) K : Intrinsically safe (KC Ex ia IIC T6/T5) W: Weatherproof to IP66
<b>Feedback Lever :</b> - Linear Type	A : Stroke (5 ~ 30mm) B : Stroke (5 ~ 65mm) C : Stroke (5 ~ 130mm) D : Stroke (80 ~ 200mm)
- Rotary Type	F : Fork lever N : Namur shaft (direct mounting)
<b>Pressure Gauge Block :</b>	0 : Not mounted 1 : 6 bar (90 psi) 2 : 10 bar (150 psi)

Description	Code
<b>Position Feedback :</b>	N : None O : Position transmitter (4 ~ 20mA output signal) L : 2 x alarm limit S : 2 x micro switch (SPDT) M : O+L Q : O+S
<b>Communication :</b>	N : None H : HART
<b>Connection Threads :</b> (pneumatic - electrical)	3 : PT(Rc) 1/4 – PF(G)1/2 4 : NPT 1/4 – NPT 1/2 5 : PT(Rc) 1/4 – M20 x 1.5
<b>Mounting Bracket :</b>	N : None L : IEC 60534-6-1 (for SS5L) R : VDI/VDE 3845 / IEC 60534-6-2 (for SS5R)
<b>Feedback Pin Guide Lever Set :</b> (only for linear type SS5L)	0 : Not included 1 : Included

## Dimensions

### - SS5L (Linear Type)

Electrical connections  
2 - PF(NPT)1/2

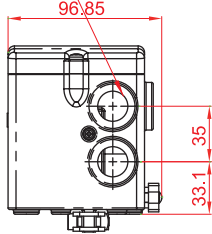

Electrical connections  
PF(NPT)1/2

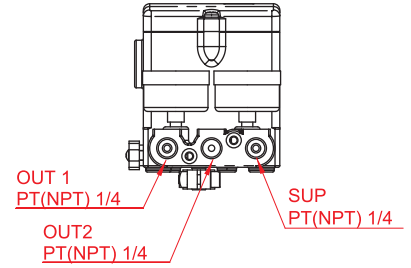
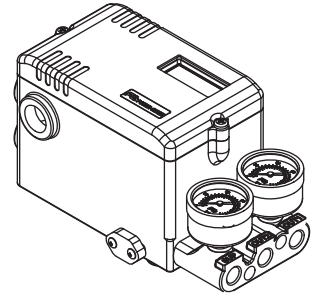
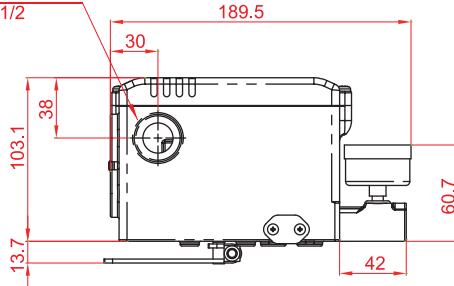

A,B,C,D TYPE LEVER

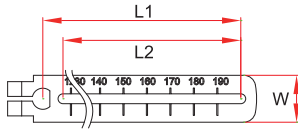

LEVER TYPE	L1(mm)	L2(mm)	W(mm)
A	30	21.40	20
B	65	55.90	20
C	130	121.40	20
D	200	191.40	20

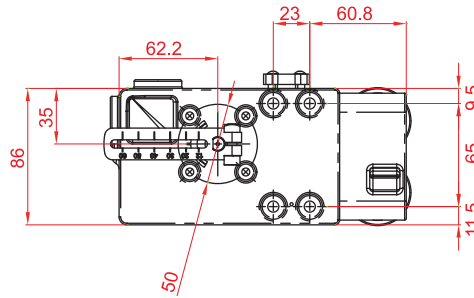

### - SS5R (Rotary Type)

Electrical connections  
2 - PF(NPT)1/2

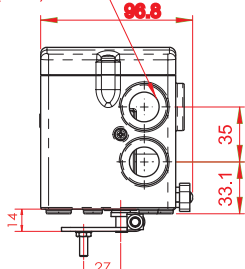

< Fork Lever Type >

Electrical connections  
PF(NPT)1/2

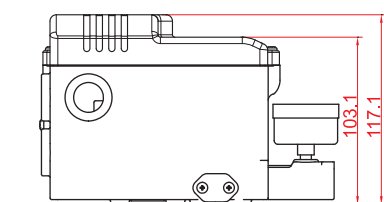
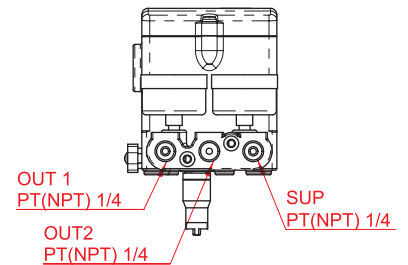
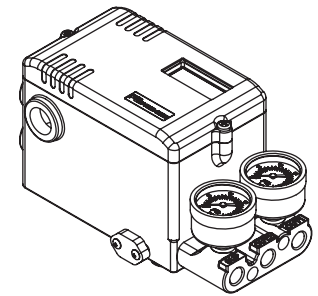
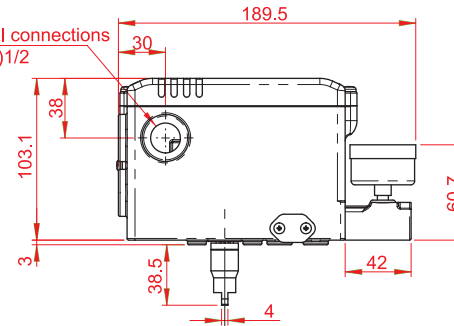

< SS5 with 2 x SPDT Micro S/W >

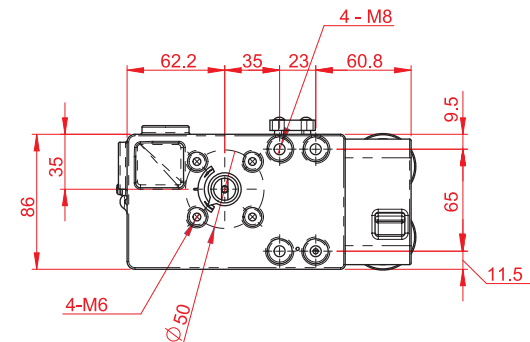



**Smartest valve control device meeting a dynamic performance and a precise setting with a piezoelectric technology and an optimized auto-calibration program**

### Features

- ▶ Auto-Calibration for optimum conditions
- ▶ Precise control performance and high dynamic response
- ▶ Easy operation with four-key pads and full text graphical LCD
- ▶ Single and double acting
- ▶ Low air consumption due to piezo electric microvalve
- ▶ Pressure regulator built-in to eliminate variations in supply air pressure
- ▶ Problem-free characteristics on a small actuator
- ▶ High resistance against shock and vibration
- ▶ Mounting on linear actuators according to IEC 534

### Options

- ▶ Position transmitter (4...20mA output signal)
- ▶ 2 x alarm limit (Min., Max.)
- ▶ Explosion proof type (KC Ex d IIB+H<sub>2</sub> T6 IP66)
- ▶ HART communication (FSK)

### Specifications

Input Signal	4 - 20 mA @ 24 VDC
Voltage Drop	8.5 VDC @ 20 mA (425 Ω)
Min. / Max. Current	3.6 mA / 50 mA
Required Load Voltage (≅ Ω @ 20mA)	Without HART : 8.5V (≅425 Ω) With HART : 9.2V (≅460 Ω)
Air Supply Pressure	1.4 - 7.0 bar (20 - 100 psi) Filtered compressed dry and non-oiled air
Output Pressure	0 - 100% supply air pressure / single or double action
Shut-off Value	Range 0 - 5% of position signal
Air Capacity	80 l/min = 4.8 N <sup>m</sup> /h = 2.8 scfm (Sup = 1.4 bar)
Air Consumption	1.3 l/min = 0.08 N <sup>m</sup> /h = 0.05 scfm (Sup = 1.4 ~ 6 bar)
Humidity Limits	< 90% RH, non-condensing
Stroke / Angle	5 ~ 80mm (max. up to 150mm) 0 ~ 90° (max. up to 100°)
Adjustable Speed	1 - 1000 (lowest 1, highest 1000)
LCD Indication	4-digit LCD indicator
Scan Time	2 ms
Valve Action	Position 0 - 100% / direct action (DA) / reverse action (RA)
Characteristic Curve	Linear, E.Q.% (1:25 or 1:50), Quick open Linearity <= 0.3% / sensitivity <= 0.2% / hysteresis <= 0.2%
Operating Temperature	- 30 ~ +70 °C
Protection Class	IP66, flameproof (KC Ex d IIB+H <sub>2</sub> T6 IP66)
Body Material	Aluminum die-cast
Pneumatic Connections	PT(Rc) 1/4 or NPT 1/4
Electrical Connections	2 x PF(G) 1/2 or NPT 1/2
Weight	2.5 kg

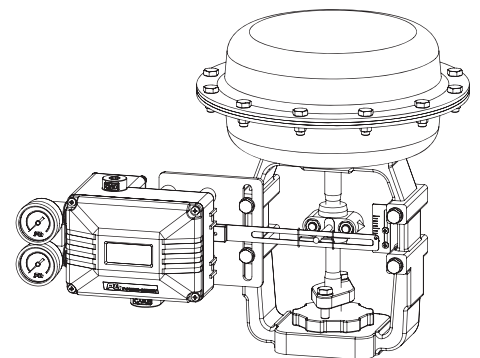

**- SSL (Linear Type)**

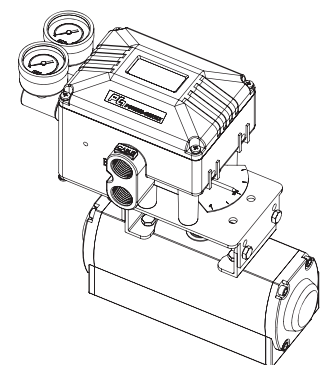

**- SSR (Rotary Type)**

**Note** : Equal percentage or Quick-open option is available. Please contact for more details

## Board View

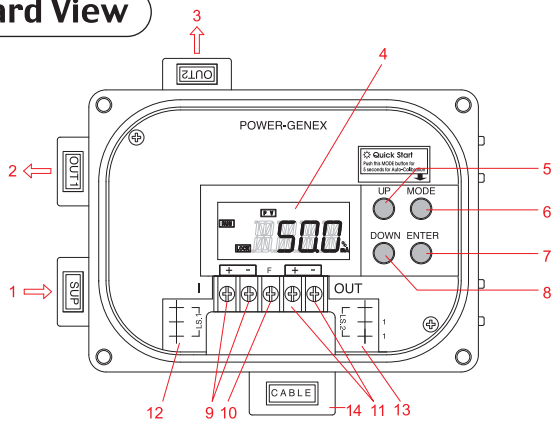

- 1 : Air supply
- 2 : Output 1
- 3 : Output 2
- 4 : Display LCD
- 5 : Up key
- 6 : Mode key
- 7 : Enter key
- 8 : Down key
- 9 : Input signal (+, -)
- 10 : Frame ground
- 11 : Output signal (+, -)
- 12 : Alarm limit 1
- 13 : Alarm limit 2
- 14 : Electrical connections

## Air Connections

### - SSL (Linear Type)

Direct Acting (DA)		Reverse Acting (RA)	
As the input signal increases, Valve stem moves downwards Actuator : DA Switch position : DA	 OUT2 must be plugged	As the input signal increases, Valve stem moves upwards Actuator : RA Switch position : RA	 OUT2 must be plugged
As the input signal increases, Valve stem moves downwards Actuator : DA Switch position : DA	 OUT1 must be plugged	As the input signal increases, Valve stem moves upwards Actuator : RA Switch position : RA	 OUT1 must be plugged
As the input signal increases, Valve stem moves downwards Switch position : DA	 OUT1 must be plugged	As the input signal increases, Valve stem moves upwards Switch position : RA	 OUT2 must be plugged

### - SSR (Rotary Type)

Spring Return	Double Acting	Double Acting
 Actuator : RA Indicator position	 Actuator : RA Indicator position	 Actuator : DA Indicator position
As the input signal increases, Actuator shaft rotates counter-clockwise	As the input signal increases, Actuator shaft rotates counter-clockwise	As the input signal increases, Actuator shaft rotates clockwise
<b>Spring Return</b>	<b>Double Acting</b>	
Reverse Acting	Out 1 : piped, Out2 : plugged	Out 1 : piped to Actuator port A, Out2 : piped to Actuator port B
Direct Acting	Out 1 : plugged, Out2 : piped	Out 1 : piped to Actuator port B, Out2 : piped to Actuator port A



## Measuring 4–20mA Output Signal

### 1) Specifications

Output Signal	4 - 20 mA, 2 - wire
Power Supply Rating	15 - 30V DC
Recommended Power Supply	24V DC
Operating Temperature	-20 - +70 °C
Input Impedance	0 - 430 Ω
Characteristic	Linear
Linearity	1.0 % F.S.
Hysteresis	0.5 % F.S.
Repeatability	± 0.5 % F.S.
Adjustment	Zero and span
Rotary Angle	50...90° (max. 100°)

### 2) With mA Loop Calibrator

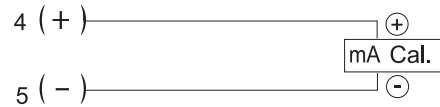

### 3) With Multi-Meter

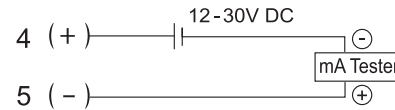

## Electrical Connections

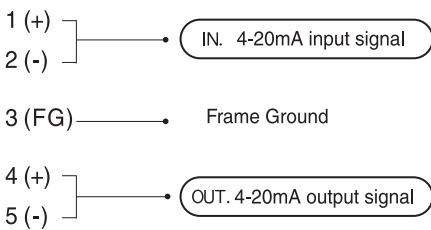

## Setting Alarm Limits

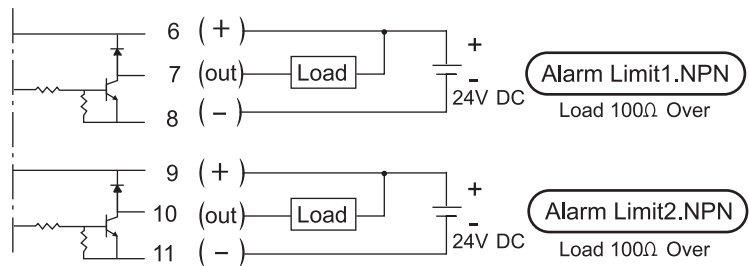

## How to Order

# SS

Actuator Operation

Protection Class

Feedback Lever

Pressure Gauge (SUP. OUT)

Position Feedback

HART Communication

Connection Threads

Mounting Bracket

Description	Code
<b>Actuator Operation :</b>	L : Linear type R : Rotary type
<b>Protection Class :</b>	F : Flameproof (KC Ex d IIB+H <sub>2</sub> T6 IP66) W : Weatherproof to IP66
<b>Feedback Lever :</b>	A : Stroke (5~40mm) B : Stroke (5~80mm) C : Stroke (up to 150mm) F : Fork lever N : NAMUR shaft(direct mounting)
<b>Pressure Gauge :</b>	1 : 6 bar (90 psi) 2 : 10 bar (150 psi)

Description	Code
<b>Position Feedback :</b>	N : None O : Position transmitter (4~20mA output signal) L : 2 x alarm limit M : O + L
<b>HART Communication :</b>	N : None H : HART Communication
<b>Connection Threads :</b> (pneumatic - electrical)	3 : PT(Rc) 1/4 - PF(G) 1/2 4 : NPT 1/4 - NPT 1/2 5 : PT(Rc) 1/4 - M20 x 1.5
<b>Mounting Bracket :</b>	N : None L : DIN / IEC 534 R : Multi-size bracket for DIN VDI/VDE 3845 (130x30x50 bracket on request)

## Dimensions

### - SSL (Linear Type)

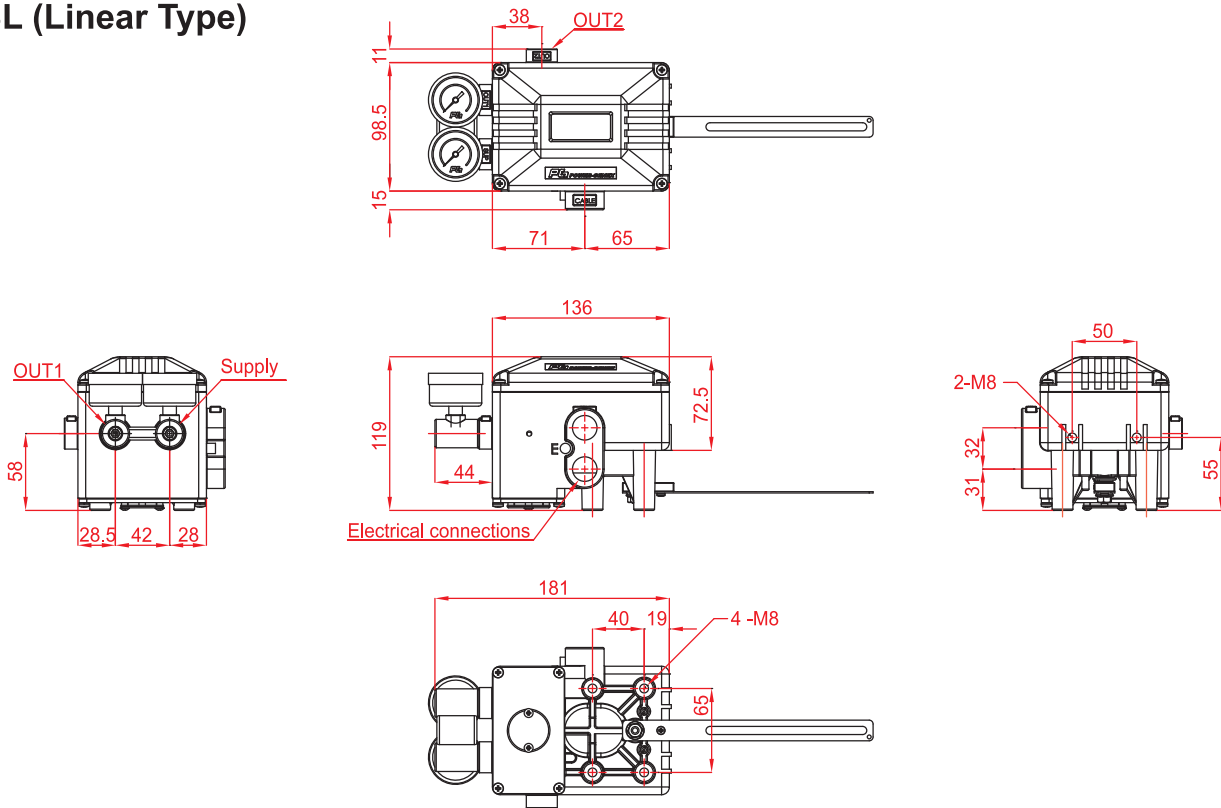

### - SSR (Rotary Type)

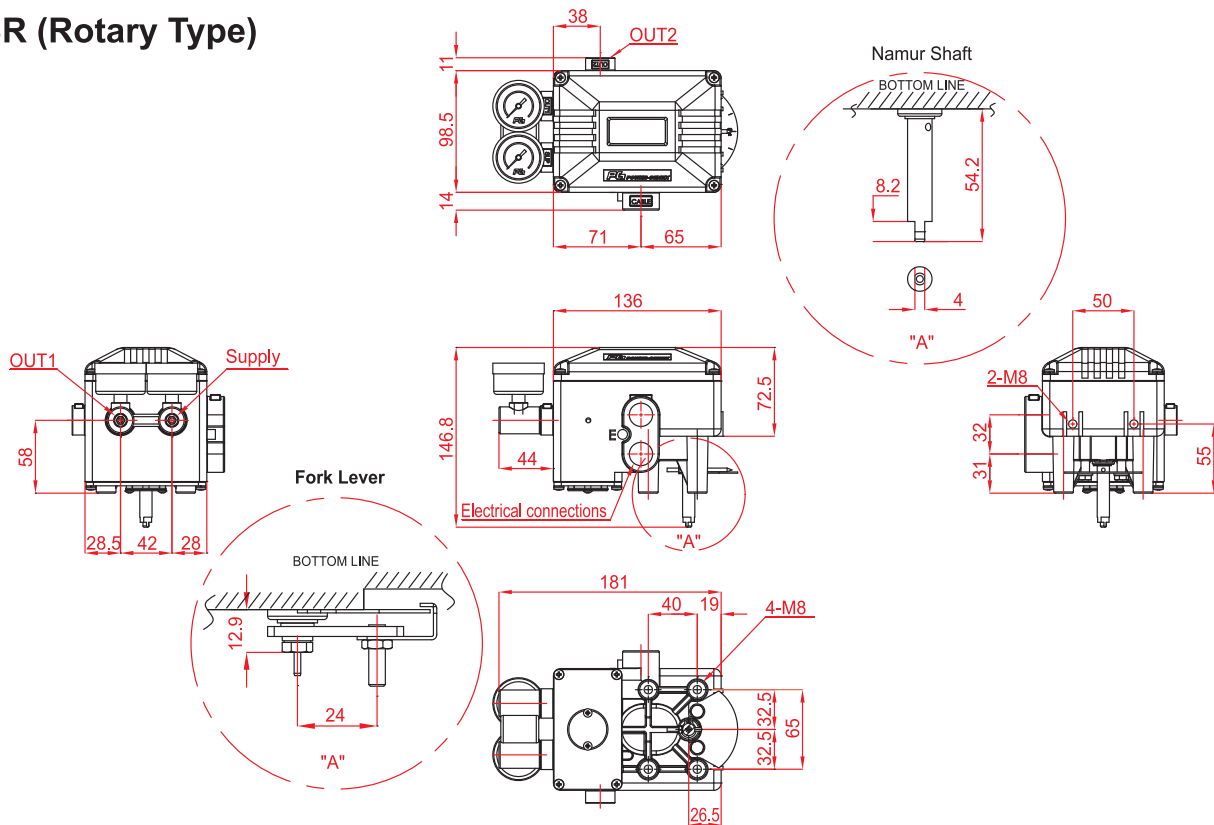



**Reliable valve control device guaranteeing optimum span and zero settings by smart auto-calibration function**

### Features

- ▶ Auto-Calibration for optimum zero and span setting
- ▶ Simple and easy to set
- ▶ Precise control performance and high dynamic response
- ▶ Pressure regulator built in to eliminate variations in supply air pressure
- ▶ Low air consumption due to piezo electric microvalve
- ▶ Input / output signal isolated
- ▶ Automatic detection for DA(direct acting) or RA(reverse acting)
- ▶ Single and double acting available
- ▶ No hunting on the small actuators
- ▶ 1/2 split range available
- ▶ High resistance against shock and vibration

### Options

- ▶ Position transmitter (4...20mA output signal)
- ▶ 2 x alarm limit (open, close)
- ▶ Explosion proof type (KC Ex d IIB+H<sub>2</sub> T6 IP66)

### Specifications

Input Signal	4 - 20 mA DC
Voltage Supply Min. /Max.	8.5V DC / 30V DC (425 ohm)
Power Consumption	30.8 mW @ 4 mA / 170 mW @ 20 mA
Characteristic	Linear (Note)
Stroke / Angle	5 - 65 mm (max. up to 150 mm) / 0° - 90°
Air Supply Pressure	1.5 - 7.0 bar (20 - 100 psi) Pressurized air or allowed gas, free of water, oil, and dust
Air Capacity	80 l/min = 4.8 N <sup>m</sup> /h = 2.8 scfm (Sup = 1.4 bar)
Air Consumption	1.3 l/min = 0.08 N <sup>m</sup> /h = 0.05 scfm (Sup = 1.4 ~ 6 bar)
Output Pressure Range	0 - 100% of supply air pressure
Linearity	Within ± 0.5 %
Hysteresis	Within 0.2 %
Sensitivity	Within ± 0.2 %
Operating Temperature	- 30 ~ +80 °C
Pneumatic Connections	PT(Rc) 1/4 or NPT 1/4
Electrical Connections	2 x PF(G) 1/2 or NPT 1/2
Protection Class	IP66, flameproof (KC Ex d IIB+H <sub>2</sub> T6 IP66)
Body Material	Aluminum die-cast
Weight	2.5 kg

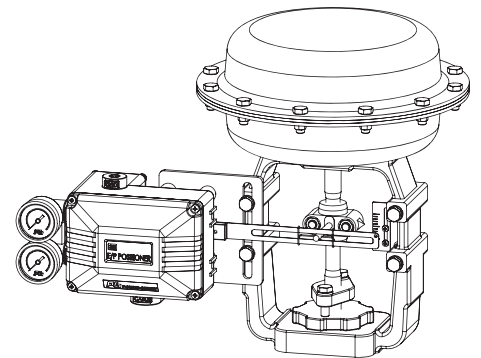

**- SEL (Linear Type)**

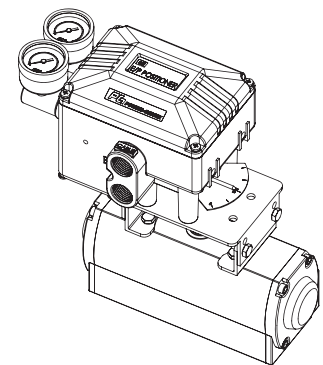

**- SER (Rotary Type)**

**Note** : Equal percentage or Quick-open option is available.  
Please contact for more details

## Board View

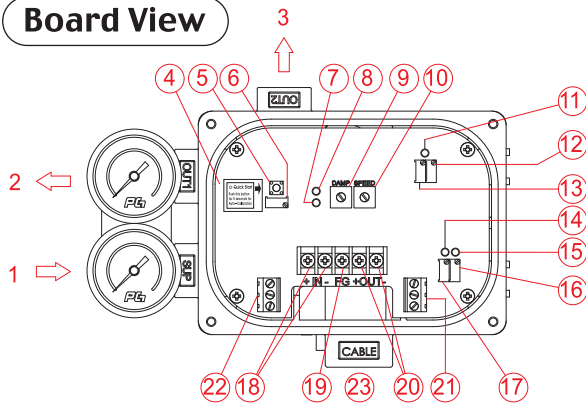

① Supply air	⑬ Feedback zero
② OUT 1	⑭ Limit switch lamp 2
③ OUT 2	⑮ Limit switch lamp 2
④ Board cover	⑯ Limit switch 2 adjusting screw
⑤ Auto-setting button	⑰ Limit switch 1 adjusting screw
⑥ Span adjusting screw	⑱ Input signal +, -
⑦ DA lamp	⑲ Frame ground
⑧ RA lamp	⑳ Output signal +, -
⑨ Damping screw	㉑ Limit switch 2 terminal
⑩ Speed adjusting screw	㉒ Limit switch 1 terminal
⑪ Feedback lamp	㉓ Electrical connections
⑫ Feedback span	

## Air Connections

### - SEL (Linear Type)

Direct Acting (DA)	
As the input signal increases, Valve stem moves downwards Actuator : DA Switch position : DA	 OUT2 must be plugged
As the input signal increases, Valve stem moves downwards Actuator : DA Switch position : DA	 OUT1 must be plugged
As the input signal increases, Valve stem moves downwards Switch position : DA	

Reverse Acting (RA)	
As the input signal increases, Valve stem moves upwards Actuator : RA Switch position : RA	 OUT2 must be plugged
As the input signal increases, Valve stem moves upwards Actuator : RA Switch position : RA	 OUT1 must be plugged
As the input signal increases, Valve stem moves upwards Switch position : RA	

### - SER (Rotary Type)

Spring Return	Double Acting	Double Acting
As the input signal increases, Actuator shaft rotates counter-clockwise	As the input signal increases, Actuator shaft rotates counter-clockwise	As the input signal increases, Actuator shaft rotates clockwise
	<b>Spring Return</b>	<b>Double Acting</b>
Reverse Acting	Out 1 : piped, Out2 : plugged	Out 1 : piped to Actuator port A, Out2 : piped to Actuator port B
Direct Acting	Out 1 : plugged, Out2 : piped	Out 1 : piped to Actuator port B, Out2 : piped to Actuator port A

## Measuring 4–20mA Output Signal

### 1) Specifications

Output Signal	4 - 20 mA, 2 - wire
Power Supply Rating	15 - 30V DC
Recommended Power Supply	24V DC
Operating Temperature	-20 - +70 °C
Input Impedance	0 - 430 Ω
Characteristic	Linear
Linearity	1.0 % F.S.
Hysteresis	0.5 % F.S.
Repeatability	± 0.5 % F.S.
Adjustment	Zero and span
Rotary Angle	50...90° (max. 100°)

### 2) With mA Loop Calibrator

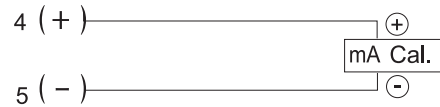

### 3) With Multi-Meter

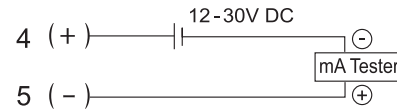

## Electrical Connections

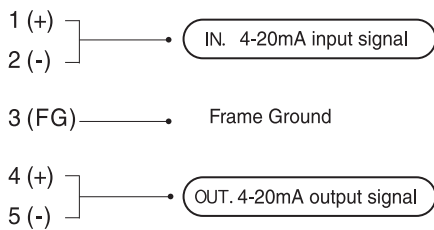

## Setting Alarm Limits

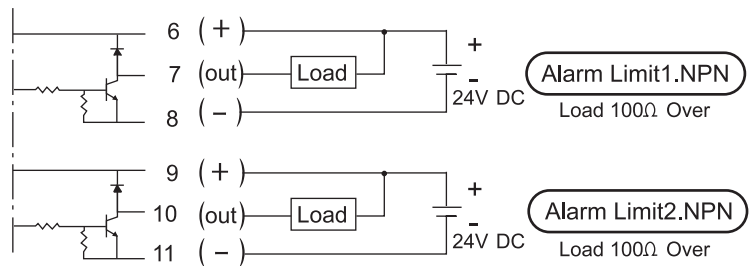

## How to Order

# SE

Actuator Operation

Protection Class

Feedback Lever

Pressure Gauge (SUP. OUT)

Position Feedback

Connection Threads

Mounting Bracket

Description	Code
<b>Actuator Operation :</b>	L : Linear type R : Rotary type
<b>Protection Class :</b>	F : Flameproof (KC Ex d IIB+H <sub>2</sub> T6 IP66) W : Weatherproof to IP66
<b>Feedback Lever :</b>	A : Stroke (5~40mm) B : Stroke (5~80mm) C : Stroke (up to 150mm) F : Fork lever N : NAMUR shaft(direct mounting)
<b>Pressure Gauge :</b>	1 : 6 bar (90 psi) 2 : 10 bar (150 psi)

Description	Code
<b>Position Feedback :</b>	N : None O : Position transmitter (4~20mA output signal) L : 2 x alarm limit M : O + L
<b>Connection Threads :</b> (pneumatic - electrical)	3 : PT(Rc) 1/4 - PF(G) 1/2 4 : NPT 1/4 - NPT 1/2 5 : PT(Rc) 1/4 - M20 x 1.5
<b>Mounting Bracket :</b>	N : None L : DIN / IEC 534 R : Multi-size bracket for DIN VDI/VDE 3845 (130x30x50 bracket on request)

Ex) SEL-WA10N (weatherproof, 5 - 65mm stroke, 10 bar pressure gauges, position transmitter)



## Dimensions

### - SEL (Linear Type)

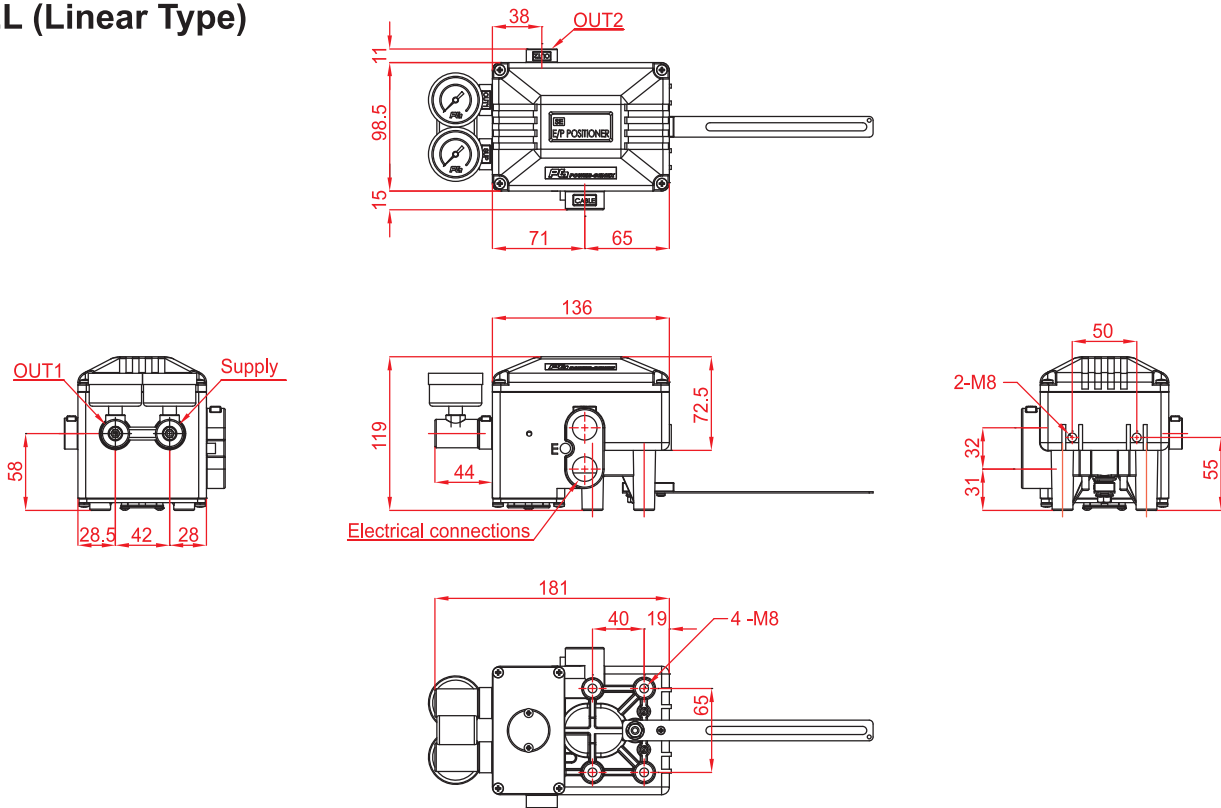

### - SER (Rotary Type)

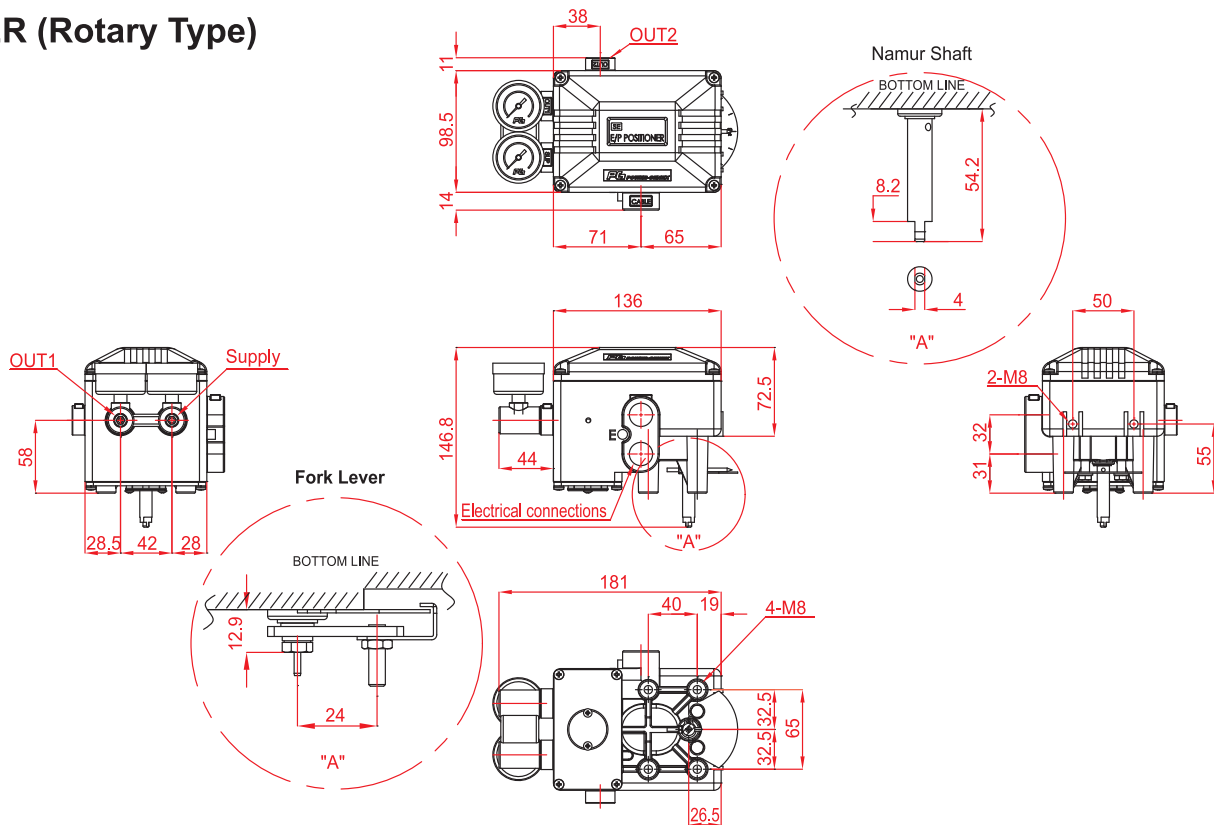



**Robust valve control device giving a confidence in reliable performance and outstanding durability under harsh working environments**

### Features

- ▶ Easy maintenance
- ▶ Precise calibration with simple SPAN and ZERO adjustments
- ▶ Simple conversion to direct acting or reverse acting
- ▶ 1/2 split range available
- ▶ Rugged aluminum housing with corrosion-resistant coating
- ▶ Vibration resistant design
- ▶ Stainless steel gauges standard
- ▶ Restricted pilot valve orifice kit for small actuators included
- ▶ KC<sup>s</sup> KC-certified flameproof Ex dmb IIB+H<sub>2</sub> T6
- ▶ NEPSI-certified flameproof Ex dmb IIB+H<sub>2</sub> T6
- ▶ IECEx-certified flameproof Ex dmb IIC T6/T5
- ▶ EAC ATEX / TR-CU-certified flameproof Ex dmb IIC T6/T5
- ▶ KC<sup>s</sup> KC-certified flameproof Ex dmb IIC T6/T5
- ▶ IECEx-certified intrinsically safe Ex ia IIC T6
- ▶ EAC ATEX / TR-CU-certified flameproof Ex ia IIC T6
- ▶ KC<sup>s</sup> KC-certified intrinsically safe Ex ia IIC T6

### Specifications

	EPL	
	Linear Type (Lever Feedback)	
	Single	Double
Input Signal	4~20 mA DC (Note. 1)	
Input Resistance	235 ± 15 Ω	
Air Supply	Max. 7.0 bar (100 psi) free of oil, water, and moisture	
Standard Stroke	10 ~ 80mm (Note. 2)	
Pneumatic Connections	PT(Rc) 1/4 or NPT 1/4	
Electrical Connections	PF(G) 1/2 or NPT 1/2	
Protection Class	Ex dmb IIB+H <sub>2</sub> T6 / Ex dmb IIC T6/T5 Ex ia IIC T6 / IP66	
Ambient Temperature	-20 ~ +70°C (Note. 3)	
Pressure Gauge	Stainless steel	
Output Characteristics	Linear	
Linearity	Within ± 1.0 % F.S	Within ± 1.5 % F.S
Sensitivity	Within ± 0.2 % F.S	Within ± 0.5 % F.S
Hysteresis	Within 1.0 % F.S	
Repeatability	Within ± 0.5 % F.S	
Air Consumption	5 LPM (Sup. 1.4 kgf/cm <sup>2</sup> )	
Flow Capacity	80 LPM (Sup. 1.4 kgf/cm <sup>2</sup> )	
Material	Aluminum die-cast	
Weight	3.3 kg (with terminal box) 3.0 kg (without terminal box)	

### Options

- ▶ Position transmitter (4...20 mA output signal)
- ▶ High temperature (+120 °C)
- ▶ Low temperature (-40 °C)

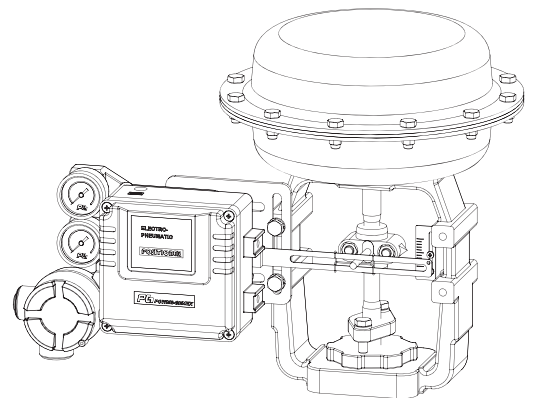

up to +120 °C without feedback options  
 3) Temperature option : up to +85 °C with feedback options  
 up to -40 °C without feedback options

**Note** : 1) 1/2 split range is available for 4~12mA input signal or 12~20mA input signal  
 2) Feedback lever can be extended to stroke 80 ~ 150mm

## Position Transmitter Options (Built-in Type)

### 1. Board View

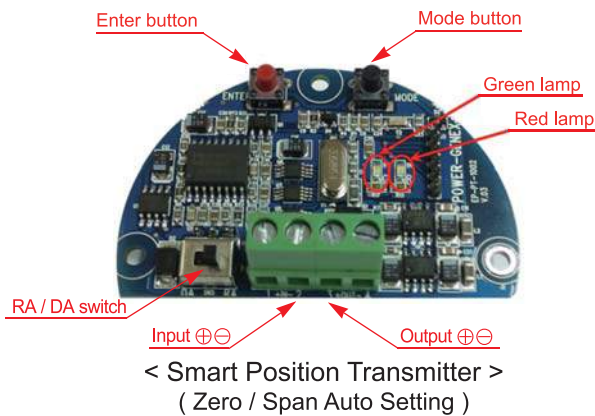
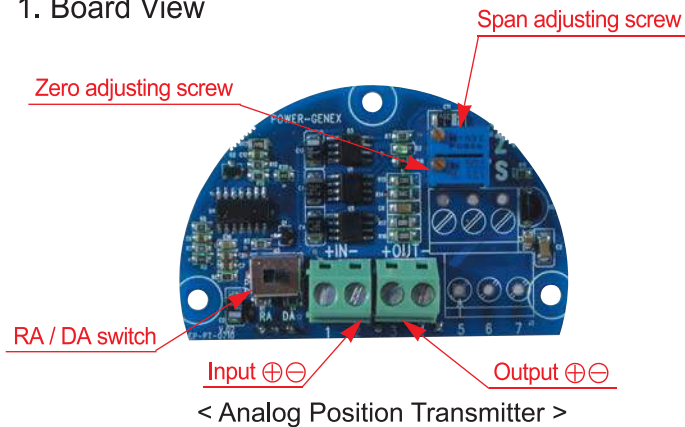

### 2. Position Transmitter (4-20mA output signal)

#### a. Specifications

Power Supply Rating	5.5 - 30 VDC loop power
Recommended Power Supply	24 VDC
Output Signal	4 - 20 mA, 2-wire
Operating Temperature	-20°C ~ +85°C
Load Impedance	0 ~ 600 ohms
Max. Output	30 mA DC
Linearity	±1.0 %
Hysteresis	1.0 % of full scale
Repeatability	±0.5 % of full scale
Adjustment	Zero and Span in terminal box

#### b. with mA calibrator

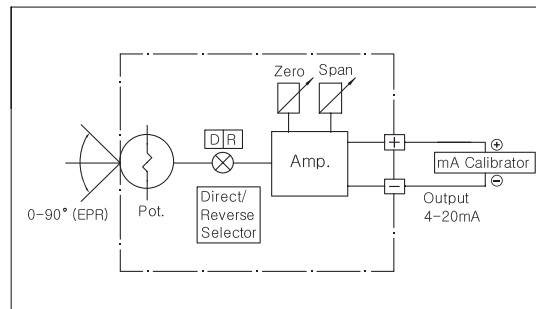

#### c. with multimeter

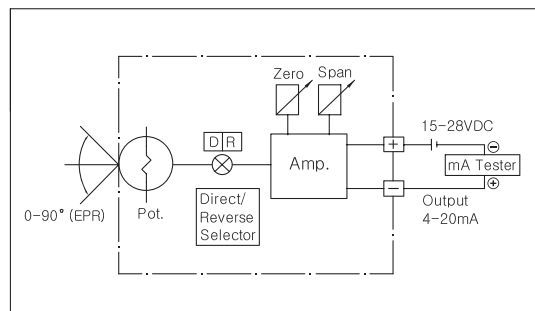

### 3. Wiring Diagram

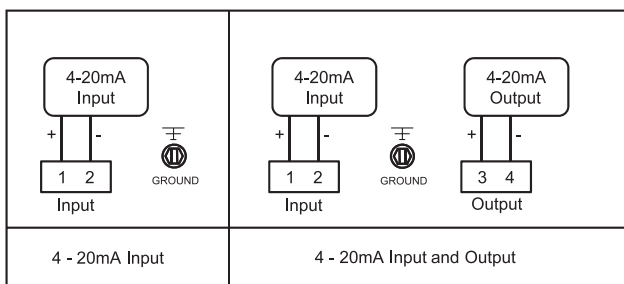

## Application for Limit Switches (External Type)

### 1) With explosion proof PTP-L

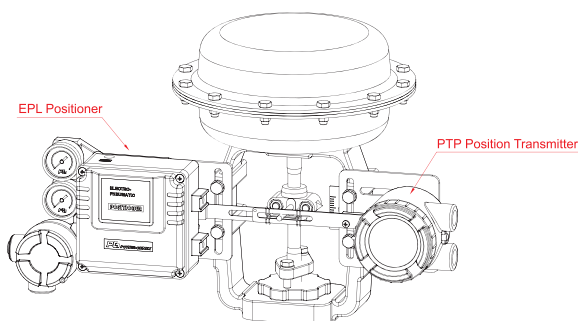

### 2) With non-explosion proof LSB-200

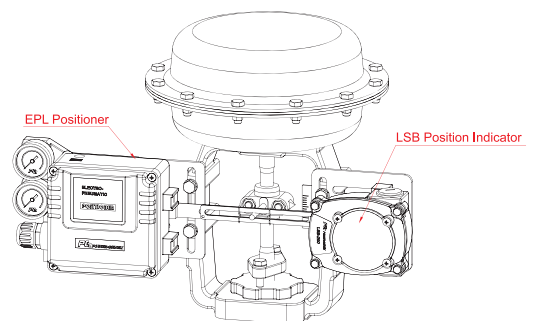

## Mounting

1. Install the EPL positioner so that the angle between the valve stem and the feedback lever can be  $90^\circ$  at 12mA input signal (50%) as shown to the right.
2. The operating angle of the EPL feedback lever is minimum  $10^\circ$  to maximum  $30^\circ$ .

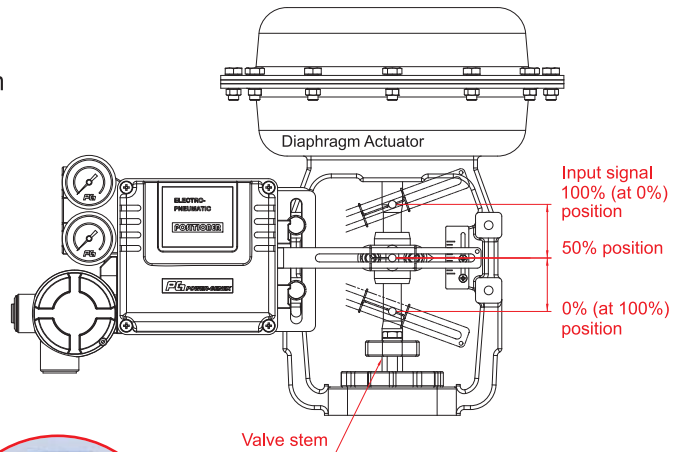

## Internal View

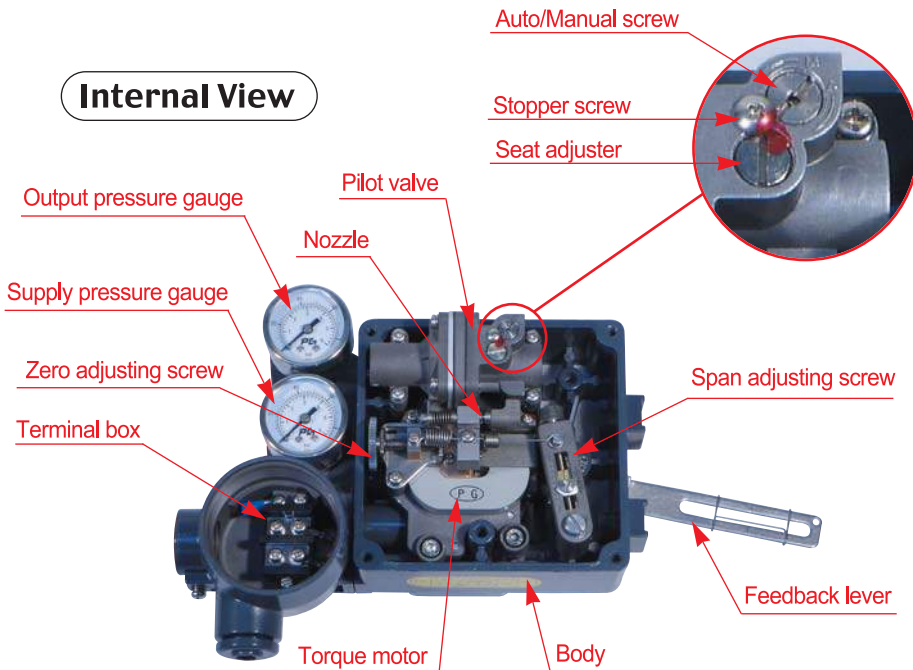

## Air Connections

### Direct Acting (DA)

As the input signal increases, Valve stem moves downwards Actuator : DA Connection : out 1	
As the input signal increases, Valve stem moves downwards Actuator : DA Connection : out 2	
As the input signal increases, Valve stem moves downwards	

### Reverse Acting (RA)

As the input signal increases, Valve stem moves upwards Actuator : RA Connection : out 2	
As the input signal increases, Valve stem moves upwards Actuator : RA Connection : out 1	
As the input signal increases, Valve stem moves upwards	

## How to Order

EPL	Protection Class	Feedback Lever	Pressure Gauge (SUP. OUT)	Pilot Valve Orifice	Position Feedback	Connection Threads	Operating Temp.	Mounting Bracket
<b>Description</b>	<b>Code</b>	<b>Description</b>	<b>Code</b>					
<b>Protection Class :</b>	F : KC / NEPSI flameproof Ex dmb IIB+H <sub>2</sub> T6 A : KC flameproof Ex dmb IIC T6/T5 D : IECEx / ATEX / TR-CU flameproof Ex dmb IIC T6/T5 I : IECEx / ATEX / TR-CU / KC intrinsically safe Ex ia IIC T6 W : Weatherproof to IP66	<b>Position Feedback :</b> (only for weatherproof type)	N : None (standard) O : Analog position transmitter (4 ~ 20mA output signal) S : Smart position transmitter (4 ~ 20mA output signal)					
<b>Feedback Lever :</b>	A : Stroke 10 ~ 40mm B : Stroke 10 ~ 80mm C : Stroke 80 ~ 150mm	<b>Connection Threads :</b> (pneumatic - electrical)	3 : PT(Rc) 1/4 - PF(G) 1/2 (standard) 4 : NPT 1/4 - NPT 1/2 5 : PT(Rc) 1/4 - M20 x 1.5					
<b>Pressure Gauge :</b>	1 : 6 bar (90 psi) 2 : 10 bar (150 psi)	<b>Operating Temperature :</b> (only for weatherproof type)	T : 70°C (standard) H : 120°C (without position feedback option) 85°C (with position feedback option) L : -40°C (without position feedback option)					
<b>Pilot Valve Orifice :</b>	S : Standard (Actuator volume over 180cm <sup>3</sup> ) M : Small orifice (φ1.0 or φ0.7) (Actuator volume over 90 ~ 180cm <sup>3</sup> )	<b>Mounting Bracket :</b>	N : None L : IEC 60534-6-1					

## Dimensions

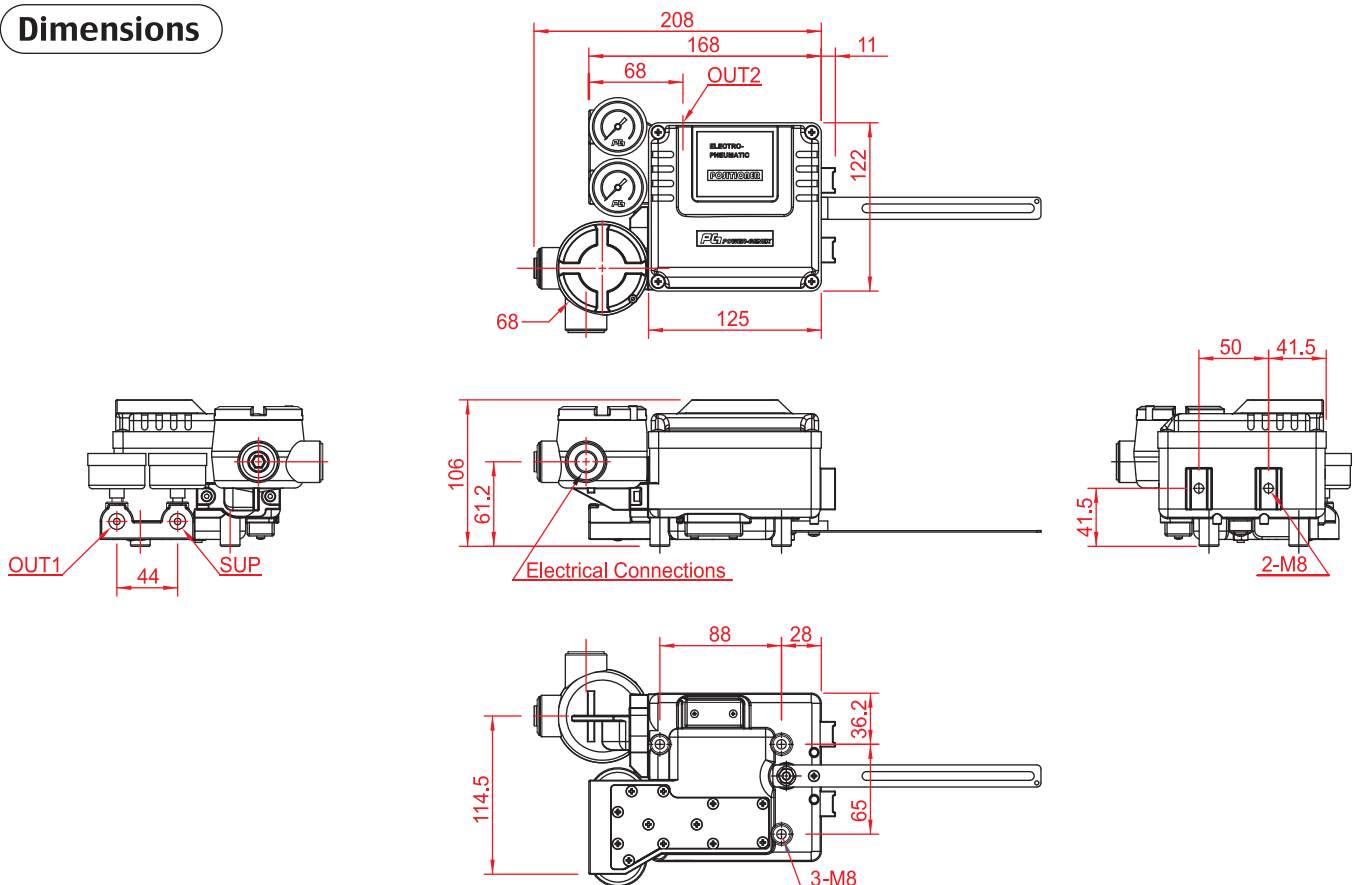





**Robust valve control device giving a confidence in reliable performance and outstanding durability under harsh working environments**

### Features

- ▶ Easy maintenance
- ▶ Precise calibration with simple SPAN and ZERO adjustments
- ▶ Simple conversion to direct acting or reverse acting
- ▶ 1/2 split range available
- ▶ Rugged aluminum housing with corrosion-resistant coating
- ▶ Vibration resistant design
- ▶ Stainless steel gauges standard
- ▶ Restricted pilot valve orifice kit for small actuators included
- ▶ KC-certified flameproof Ex dmb IIB+H<sub>2</sub> T6
- ▶ NEPSY-certified flameproof Ex dmb IIB+H<sub>2</sub> T6
- ▶ IECEX / KC-certified flameproof Ex dmb IIC T6/T5
- ▶ ATEX / TR-CU-certified flameproof Ex dmb IIC T6/T5
- ▶ IECEX / KC-certified intrinsically safe Ex ia IIC T6
- ▶ ATEX / TR-CU-certified flameproof Ex ia IIC T6

### Options

- ▶ Position transmitter (4...20 mA output signal)
- ▶ 2 x SPDT limit switch
- ▶ 2 x P&F proximity sensor NJ2-V3-N
- ▶ Visual dome indicator
  - ▶ High temperature (+120°C)
  - ▶ Low temperature (-40°C)

### Specifications

	EPR	
	Rotary Type (Cam Feedback)	
	Single	Double
Input Signal	4~20 mA DC (Note. 1)	
Input Resistance	235 ± 15 Ω	
Air Supply	Max. 7.0 bar (100 psi) free of oil, water, and moisture	
Operating Angle	60 ~ 100° (Note. 2)	
Pneumatic Connections	PT(Rc) 1/4 or NPT 1/4	
Electrical Connections	PF(G) 1/2 or NPT 1/2	
Protection Class	Ex dmb IIB+H <sub>2</sub> T6 / Ex dmb IIC T6/T5 Ex ia IIC T6 / IP66	
Ambient Temperature	-20 ~ +70°C (Note. 3)	
Pressure Gauge	Stainless steel	
Output Characteristics	Linear	
Linearity	Within ± 1.0 % F.S	Within ± 1.5 % F.S
Sensitivity	Within ± 0.5 % F.S	
Hysteresis	Within 1.0 % F.S	
Repeatability	Within ± 0.5 % F.S	
Air Consumption	5 LPM (Sup. 1.4 kgf/cm <sup>2</sup> )	
Flow Capacity	80 LPM (Sup. 1.4 kgf/cm <sup>2</sup> )	
Material	Aluminum die-cast	
Weight	3.5 kg (with terminal box) 3.2 kg (without terminal box)	



**With Dome Indicator**

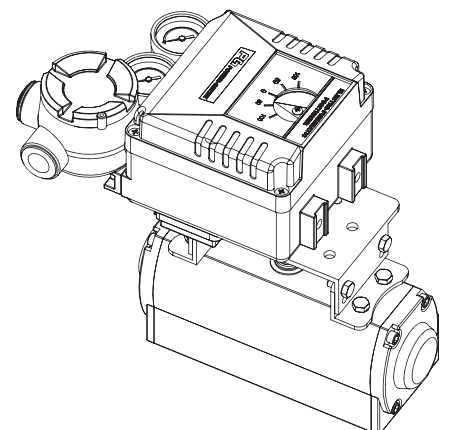

up to +120°C without feedback options  
 3) Temperature option : up to +85°C with feedback options  
 up to -40°C without feedback options

**Note** : 1) 1/2 split range is available for 4~12mA input signal or 12~20mA input signal  
 2) Operating angle can be adjusted to 0~60° or 0~100°

## Mounting

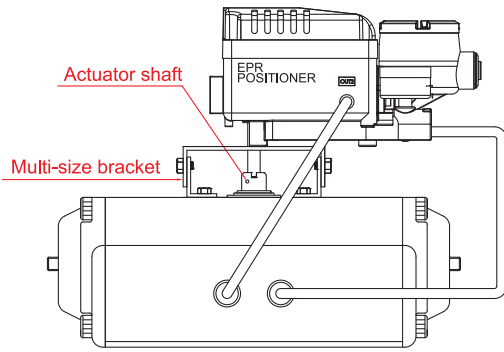

NAMUR Type Mounting

Note that feedback lever shaft "A" should be placed in the orifice of fork lever "B" and they should be in perfect alignment with a rotary actuator output shaft

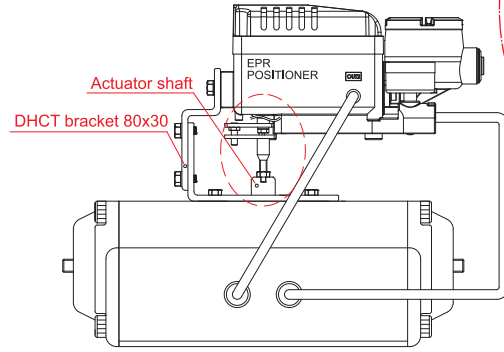

Fork Lever Type Mounting

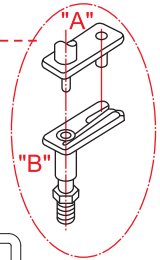

## Internal View

Auto/Manual screw  
Stopper screw  
Seat adjuster

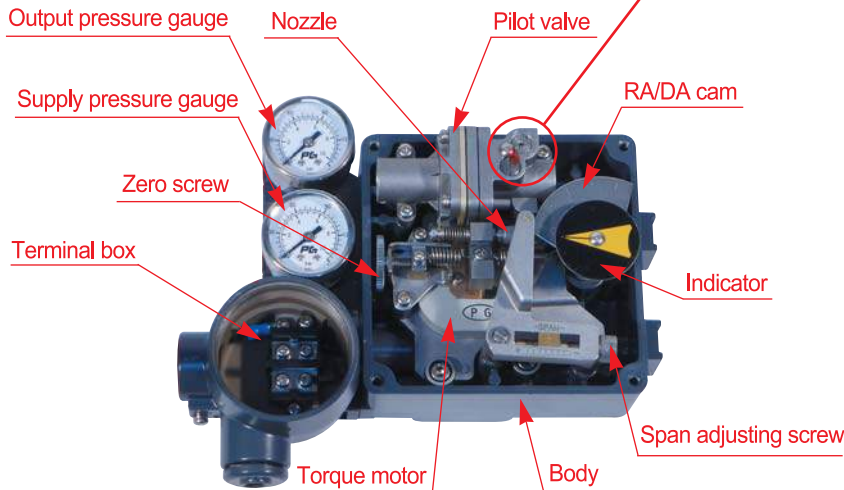
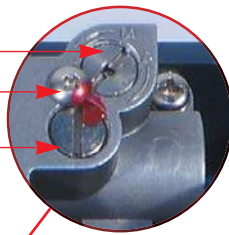

## Multi-size Bracket

TYPE	H
80 x 30 x 20H	41
80 x 30 x 30H	51
130 x 30 x 20H	41
130 x 30 x 30H	51
130 x 30 x 50H	71

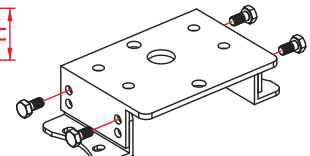
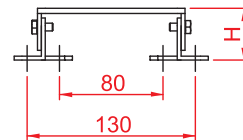
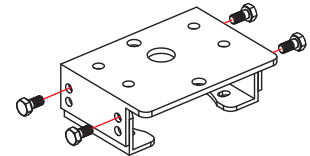
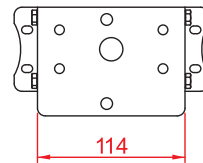

## Air Connections

### Direct Acting (DA)

As the input signal increases, Actuator stem rotates clockwise.

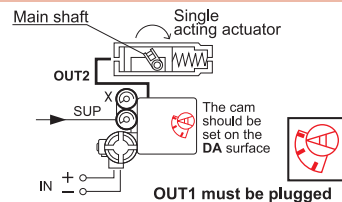

As the input signal increases, Actuator stem rotates clockwise.

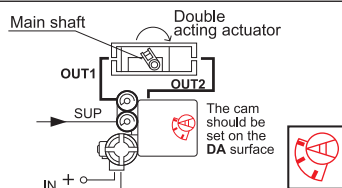

### Reverse Acting (RA)

As the input signal increases, Actuator stem rotates counter clockwise.

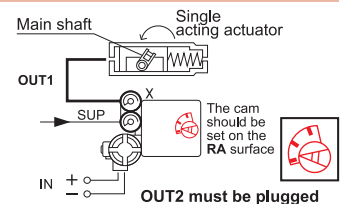

As the input signal increases, Actuator stem rotates counter clockwise.

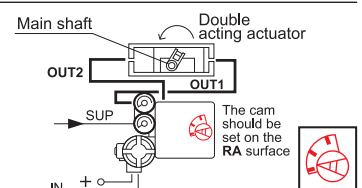

## Position Transmitter Options (Built-in Type)

### 1. Board View

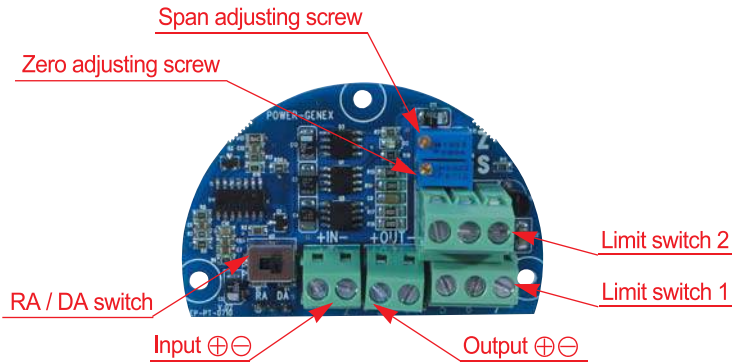

< Analog Position Transmitter & Limit Switches >

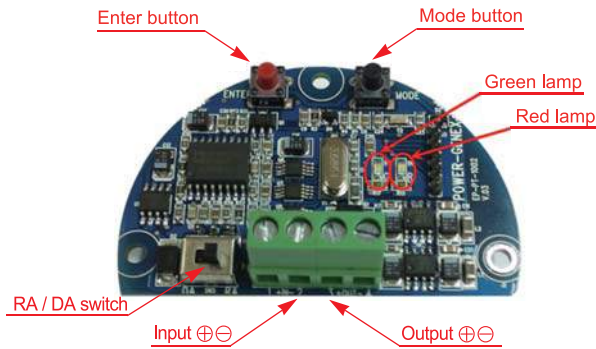

< Smart Position Transmitter >  
( Zero / Span Auto Setting )

### 2. Position Transmitter (4-20mA output signal)

#### a. Specifications

Power Supply Rating	5.5 - 30 VDC loop power
Recommended Power Supply	24 VDC
Output Signal	4 - 20 mA, 2-wire
Operating Temperature	-20 °C ~ +85 °C
Load Impedance	0 ~ 600 ohms
Max. Output	30 mA DC
Linearity	±1.0 %
Hysteresis	1.0 % of full scale
Repeatability	±0.5 % of full scale
Adjustment	Zero and Span in terminal box

#### b. with mA calibrator

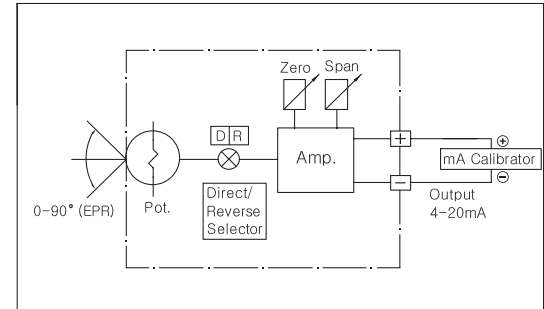

#### c. with multimeter

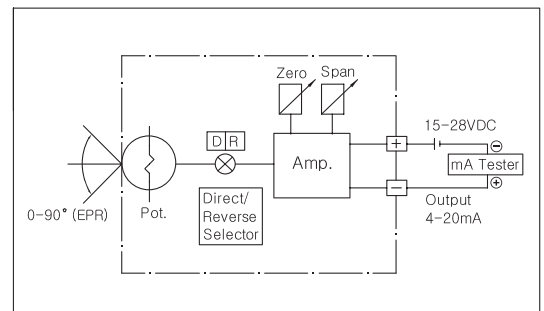

### 3. Wiring Diagram

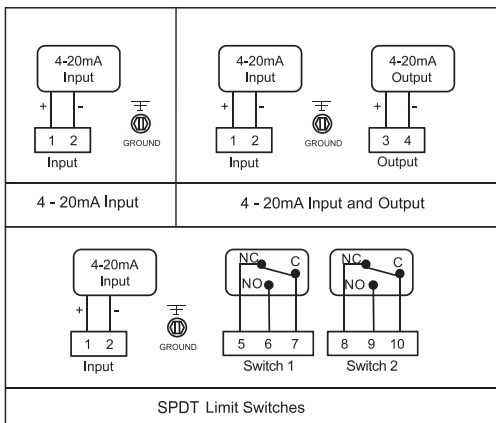

### 4. SPDT Limit Switches

#### a. Specifications

Contacts	SPDT Form C
AC Rating	16 A 1/2 HP 125/250 VAC
DC Rating	0.6 A 125 VDC / 0.3 A 250 VDC
Adjustment	Cams with set screws (L-wrench included for setting)

#### b. Wiring and Application

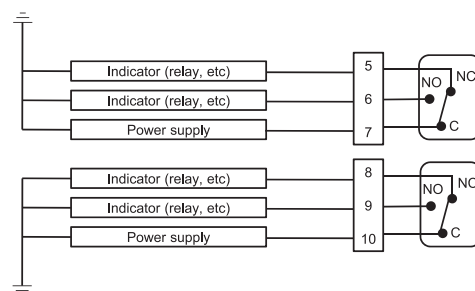

## How to Order

EPR	Protection Class	Feedback Shaft	Pressure Gauge (SUP. OUT)	Pilot Valve Orifice	Position Feedback	Connection Threads	Dome Indicator	Operating Temp.	Mounting Bracket
<b>Description</b>	<b>Code</b>								
<b>Protection Class :</b>	F : KC / NEPSI flameproof Ex dmb IIB+H <sub>2</sub> T6 A : KC flameproof Ex dmb IIC T6/T5 D : IECEX / ATEX / TR-CU flameproof Ex dmb IIC T6/T5 I : IECEX / ATEX / TR-CU / KC intrinsically safe Ex ia IIC T6 W : Weatherproof to IP66								
<b>Feedback Shaft :</b>	N : NAMUR shaft (direct mounting) A : Fork lever M6 x 40L B : Fork lever other size on request								
<b>Pressure Gauge :</b>	1 : 6 bar (90 psi) 2 : 10 bar (150 psi)								
<b>Pilot Valve Orifice :</b>	S : Standard (Actuator volume over 180cm <sup>3</sup> ) M : Small orifice (φ1.0 or φ0.7) (Actuator volume over 90 ~180cm <sup>3</sup> )								
<b>Position Feedback : (only for weatherproof type)</b>	N : None (standard) O : Analog position transmitter (4 ~ 20mA output signal) S : Smart position transmitter (4 ~ 20mA output signal) L : 2 x SPDT limit switch P : 2 x proximity sensor P&F NJ2-V3-N M : O + L Q : O + P								
<b>Description</b>	<b>Code</b>								
<b>Connection Threads :</b> (pneumatic - electrical)	3 : PT(Rc) 1/4 - PF(G) 1/2 (standard) 4 : NPT 1/4 - NPT 1/2 5 : PT(Rc) 1/4 - M20 x 1.5								
<b>Dome Indicator :</b>	N : Flat indicator (standard) D : Dome indicator								
<b>Operating Temperature :</b> (only for weatherproof type)	T : 70°C (standard) H : 120°C (without position feedback option) 85°C (with position feedback option) L : -40°C (without position feedback option)								
<b>Mounting Bracket :</b>	N : None R : Multi-size NAMUR bracket for IEC 60534-6-2 / VDI/VE 3845 (130x30x50 bracket on request) F : PG bracket 80x30 for fork lever type E : Multi-size NAMUR bracket for fork lever type (130x30x50 bracket on request)								

## Dimensions

### A. With Flat Indicator

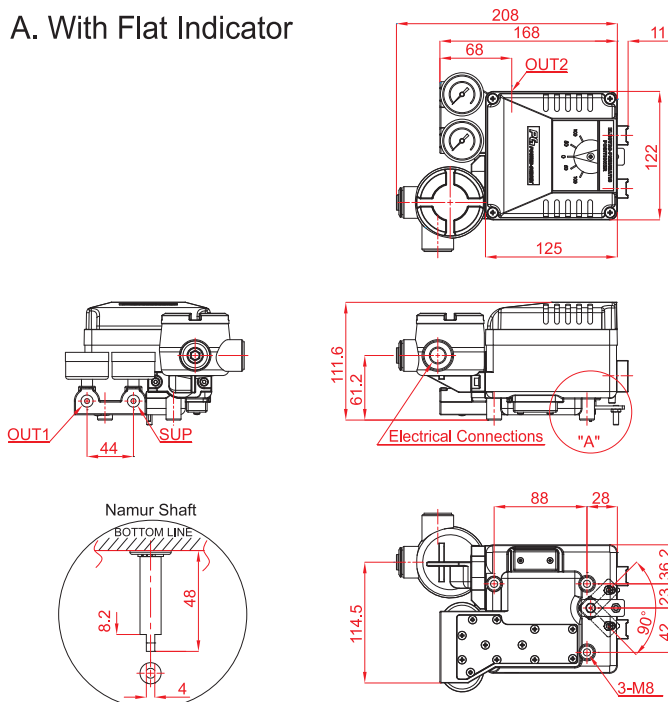

Fork Lever

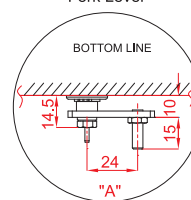

### B. With Dome Indicator

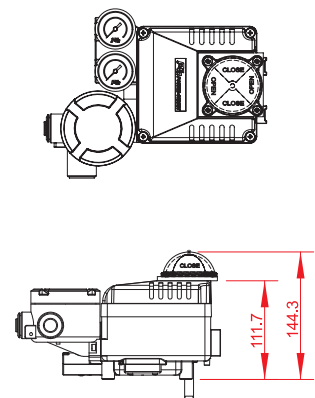





**Robust valve control device giving a confidence in reliable performance and outstanding durability under harsh working environments**

### Features

- ▶ Easy maintenance
- ▶ Precise calibration with simple SPAN and ZERO adjustments
- ▶ Simple conversion to direct acting or reverse acting
- ▶ 1/2 split range available
- ▶ Rugged aluminum housing with corrosion-resistant coating
- ▶ Vibration resistant design
- ▶ Stainless steel gauges standard
- ▶ Restricted pilot valve orifice kit for small actuators included

### Options

- ▶ High temperature

### Specifications

	PPL	
	Linear Type (Lever Feedback)	
	Single	Double
Input Signal	0.2 - 1.0 bar (3 - 15 psi) (Note.1, 2)	
Supply Air Pressure	Max. 7.0 bar (100 psi)	
Standard Stroke	10 - 80 mm (Note.3)	
Pneumatic Connections	PT(Rc) 1/4 or NPT 1/4	
Ambient Temperature	-20 ~ +70°C (Note. 4)	
Pressure Gauge	Stainless steel	
Output Characteristics	Linear	
Linearity	Within $\pm 1.0$ % F.S	Within $\pm 1.5$ % F.S
Sensitivity	Within $\pm 0.2$ % F.S	Within $\pm 0.5$ % F.S
Hysteresis	Within 1.0 % F.S	
Repeatability	Within $\pm 0.5$ % F.S	
Air Consumption	5 LPM (Sup. 1.4 bar)	
Flow Capacity	80 LPM (Sup. 1.4 bar)	
Body Material	Aluminium die-cast	
Weight	2.1 kg	

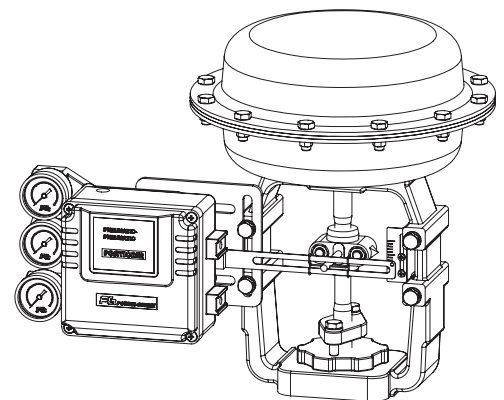

- Note** : 1) 1/2 split range is available for 3~9 psi input signal or 9~15 psi input signal  
 2) Please contact for 6~30 psi input signal  
 3) Feedback lever can be extended to stroke 80 ~ 150mm  
 4) High temperature option : up to +120 °C



## How to Order

**PPL** —

Feedback  
Lever

Pressure  
Gauge

Pilot  
Valve  
Orifice

Connection  
Threads

Operating  
Temperature

Mounting  
Bracket

Description	Code
<b>Feedback Lever :</b>	A : Stroke 10 ~ 40mm B : Stroke 10 ~ 80mm C : Stroke 80 ~ 150mm
<b>Pressure Gauge :</b>	1 : 6 bar (90psi) 2 : 10 bar (150psi)
<b>Pilot Valve Orifice :</b>	S : Standard (Actuator volume over 180cm <sup>3</sup> ) M : Small orifice (∅ 1.0 or ∅ 0.7) (Actuator volume 90 ~ 180cm <sup>3</sup> )

Description	Code
<b>Connection Threads :</b> (pneumatic)	3 : PT(Rc) 1/4 4 : NPT 1/4
<b>Operating Temperature :</b>	T : 70°C (standard) H : 120°C L : -40°C
<b>Mounting Bracket</b>	N : None L : DIN / IEC 60534-6-1

## Dimensions

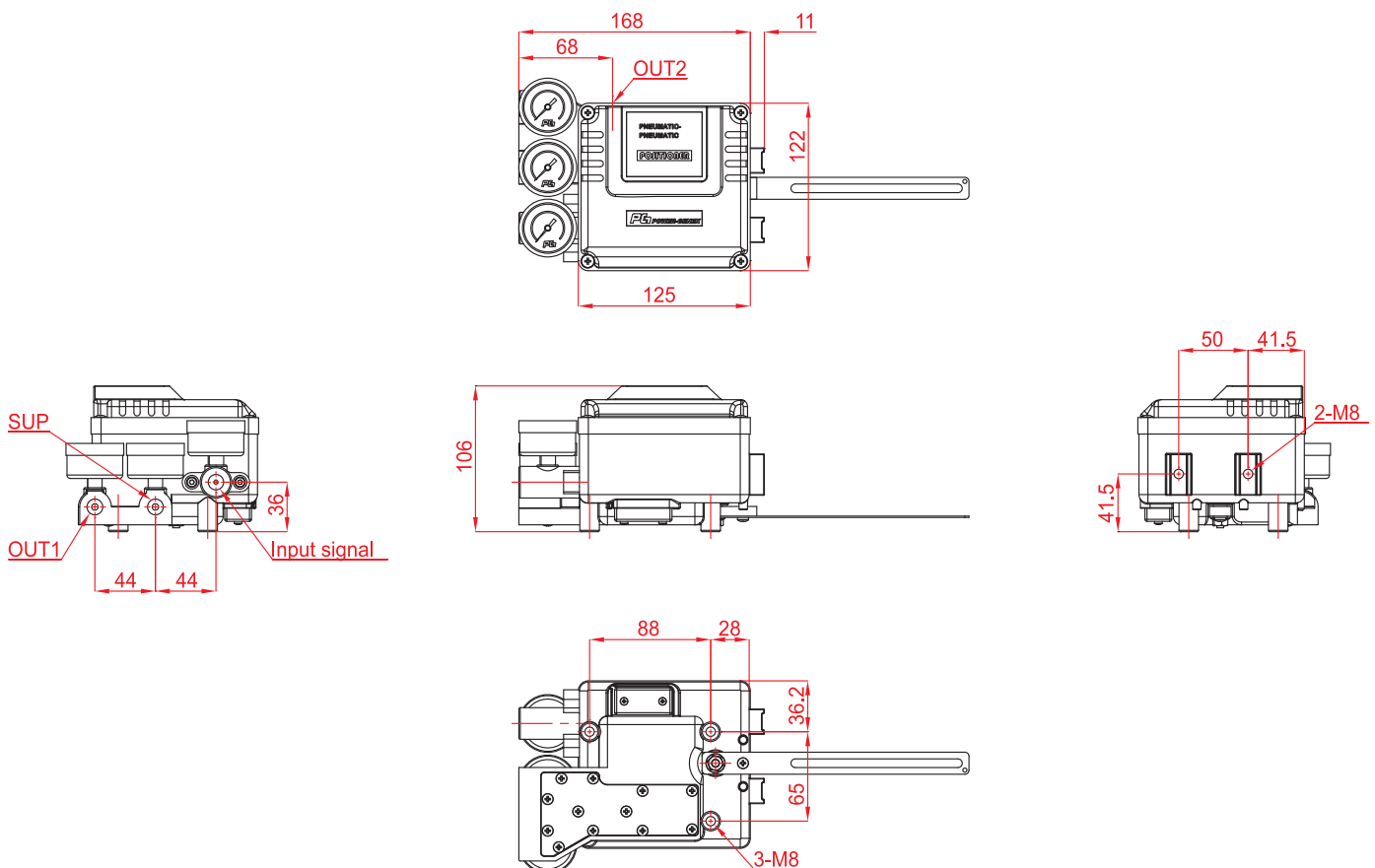

**Robust valve control device giving a confidence in reliable performance and outstanding durability under harsh working environments**



### Features

- ▶ Easy maintenance
- ▶ Precise calibration with simple SPAN and ZERO adjustments
- ▶ Simple conversion to direct acting or reverse acting
- ▶ 1/2 split range available
- ▶ Rugged aluminum housing with corrosion-resistant coating
- ▶ Vibration resistant design
- ▶ Stainless steel gauges standard
- ▶ Restricted pilot valve orifice kit for small actuators included

### Options

- ▶ Position transmitter (4-20mA output signal)
- ▶ 2 x SPDT limit switch
- ▶ 2 x P&F proximity sensor NJ2-V3-N
- ▶ Visual dome indicator
- ▶ High temperature

### Specifications

	PPR	
	Rotary Type (Cam Feedback)	
	Single	Double
Input Signal	0.2 - 1.0 bar (3 - 15 psi) (Note.1, 2)	
Supply Air Pressure	Max. 7.0 bar (100 psi)	
Standard Stroke	60 - 100° (Note.3)	
Pneumatic Connections	PT(Rc) 1/4 or NPT 1/4	
Ambient Temperature	-20 ~ +70°C (Note. 4)	
Pressure Gauge	Stainless steel	
Output Characteristics	Linear	
Linearity	Within ± 1.0 % F.S	Within ± 1.5 % F.S
Sensitivity	Within ± 0.5 % F.S	
Hysteresis	Within 1.0 % F.S	
Repeatability	Within ± 0.5 % F.S	
Air Consumption	5 LPM (Sup. 1.4 bar)	
Flow Capacity	80 LPM (Sup. 1.4 bar)	
Body Material	Aluminium die-cast	
Weight	2.5 kg	



**With Dome Indicator**

- Note** : 1) 1/2 split range is available for 3~9 psi input signal or 9~15 psi input signal  
 2) Please contact for 6~30 psi input signal  
 3) Operating angle can be adjusted to 0~60° or 0~100°  
 4) High temperature option : up to +120°C without feedback options  
 up to +85°C with feedback options

## How to Order

**PPR** —

Feedback Lever

Pressure Gauge

Pilot Valve Orifice

Position Feedback

Connection Threads

Dome Indicator

Operating Temperature

Mounting Bracket

Description	Code
<b>Feedback Shaft :</b>	N : NAMUR shaft (direct mounting) A : Fork lever M6 x 40L B : Fork lever other size on request
<b>Pressure Gauge :</b>	1 : 6 bar (90psi) 2 : 10 bar (150psi)
<b>Pilot Valve Orifice :</b>	S : Standard (Actuator volume over 180cm <sup>3</sup> ) M : Small orifice (Ø 1.0 or Ø 0.7) (Actuator volume 90 ~ 180cm <sup>3</sup> )
<b>Position Feedback :</b>	N : None (standard) O : Position transmitter (4 ~ 20mA output signal) L : 2 x SPDT limit switch P : 2 x proximity sensor P&F NJ2-V3-N M : O + L Q : O + P

Description	Code
<b>Connection Threads :</b> (pneumatic)	3 : PT(Rc) 1/4 4 : NPT 1/4
<b>Dome Indicaotr :</b>	N : Flat indicator (standard) D : Dome indicator
<b>Operating Temperature :</b>	T : 70°C (standard) H : 120°C (without position feedback option) 85°C (with position feedback option) L : -40°C (without position feedback option)
<b>Mounting Bracket</b> <b>- NAMUR Shaft Type :</b>	N : None R : Multi-size NAMUR bracket for DIN VDI/VE 3845 (130 x 30 x 50 bracket on request)
<b>- Fork Lever Type</b>	F : DHCT bracket 80x30 for fork lever type E : Multi-size NAMUR bracket for Fork lever type (130 x 30 x 50 bracket on request)

## Dimensions

### A. With Flat Indicator

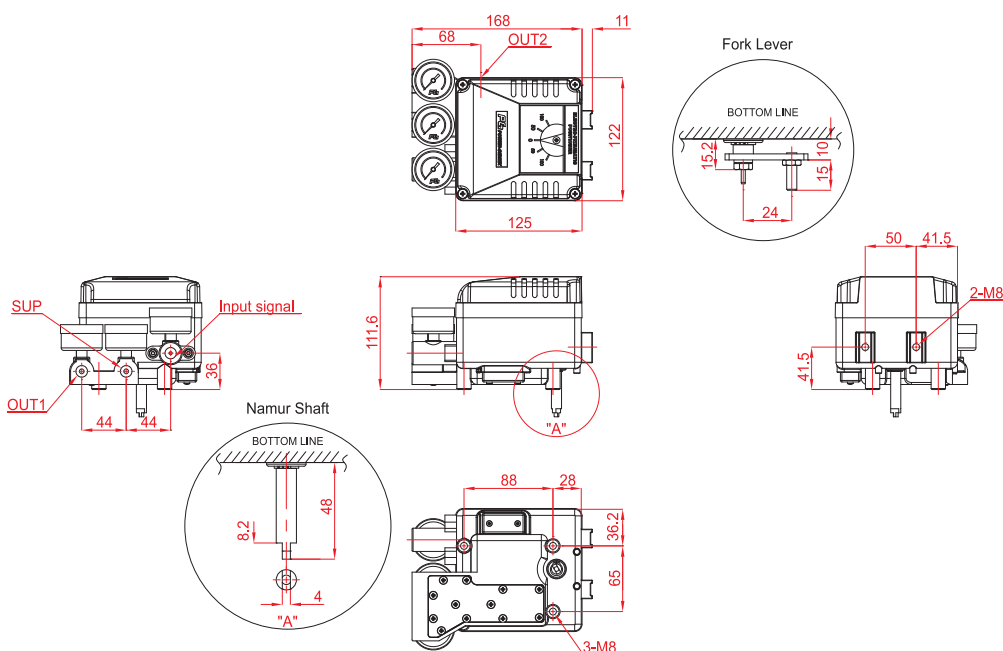

### B. With Dome Indicator

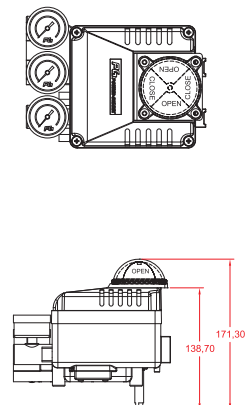



**Cylinder positioner ideally designed and optimized for cylinder actuator and guaranteeing precise and stable performance with cylinder actuator**

### Features

- ▶ Easy to set
- ▶ Compact
- ▶ Precise and stable performance
- ▶ Suitable for a wide application

### Specifications

	PPCL
Input Signal	3 ~ 15 psi (0.2 ~ 1 bar)
Air Supply	3 ~ 7 bar (100 psi) free of oil, water, and moisture
Standard Stroke	30 ~ 300mm
Pneumatic Connections	PT(Rc) 1/4 or NPT 1/4
Protection Class	IP55
Ambient Temperature	-20 ~ +70 °C *
Output Characteristics	Linear
Linearity	Within ± 1.0% F.S
Sensitivity	Within ± 0.5% F.S
Hysteresis	Within 1.0% F.S
Repeatability	Within ± 0.5% F.S
Air Consumption	5 LPM (Sup. 1.4 bar)
Material	Aluminum die-cast
Weight	1.5 kg

\* High temperature option : up to +120 °C

### How to Order

**PPCL** —

Stroke

Connections  
(Pneumatic)

Operating  
Temperature

### NOTE

Please be sure to describe a size and a stroke of the cylinder actuator required when placing an order

### CAUTION

1. Please be sure to disconnect supply air completely before opening a feedback spring protection tube.
2. When input signal increases, the PPCL can operate only in the diection that the cylinder extends.

Description	Code
Stroke :	On request (30mm ~ 300mm)
Connections : (Pneumatic - electrical)	P: PT(Rc) 1/4 - PF(G) 1/2 N: NPT 1/4 - NPT 1/2
Operating Temperature :	N: -20 ~ +70°C (standard) H: -20 ~ +120°C (high temp.)

## Dimensions

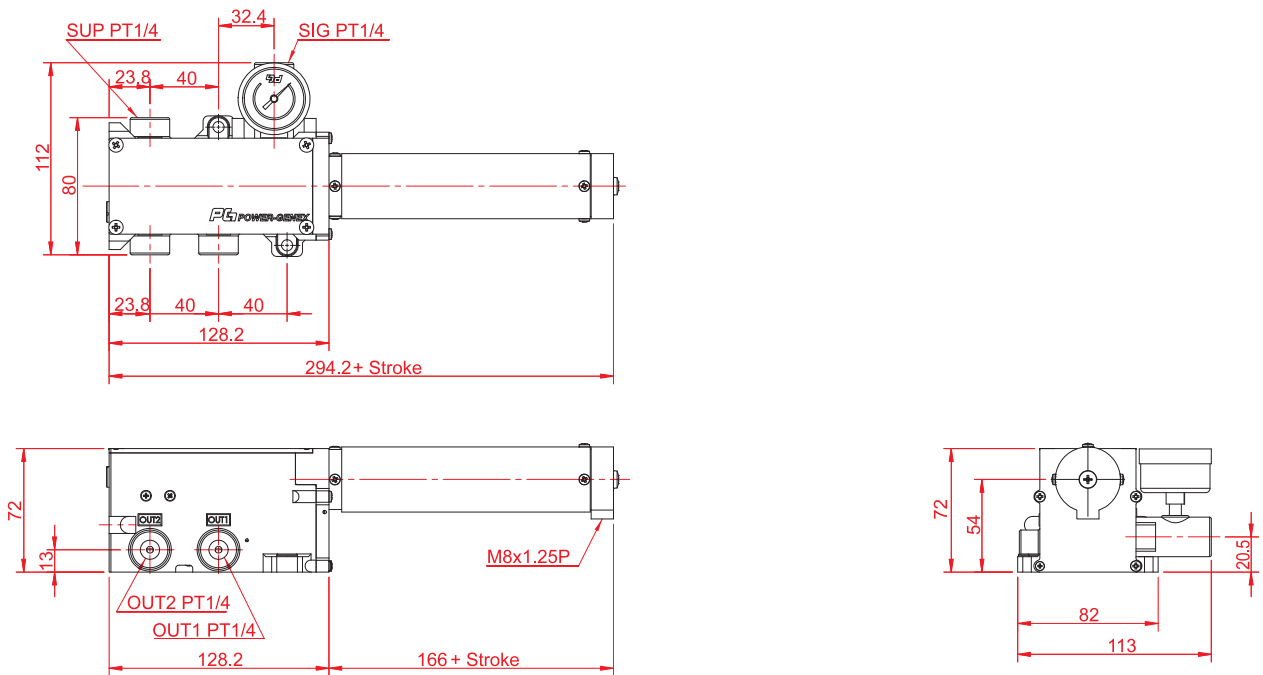





**Dynamic valve drive to convert 4-20mA current signal to pneumatic output pressure with state-of-the art piezoelectric technology**

### Features

- ▶ Rugged aluminum die-cast housing
- ▶ Precise control performance and high dynamic response
- ▶ Simple and easy to set
- ▶ Low air consumption due to piezo electric microvalve

### Specifications

Model	IPC
Input Signal	4 - 20 mA @ 24 VDC, 2-wire
Output Pressure	Max. 3 bar (45 psi)
Air Supply Pressure	1.4 - 4 bar (20 - 60 psi)
Air Consumption	1.3 l/min = 0.08 N <sup>m</sup> /h = 0.05 scfm
Output Characteristic	Linear to input signal
Action	Direct
Total Error	Max. error ±0.3% of span (linearity + hysteresis + repeatability)
Supply Air	Filtered compressed, dry and non-oiled air (up to 5 micron)
Operating Temperature	-20°C - +70°C
Protection Class	IP55
Impedance	425 Ω @ 20 mA
Mounting Type	Rail (to DIN EN 50022)
Pneumatic Connection	PT(Rc) 1/8
Electrical Connections	PG 9
Body Material	Aluminum die-cast
Weight	820 g

### How to Order

Output Pressure	Required Supply Air	Part Number
0 - 1 bar (0 - 15 psi)	1.5 bar (23 psi)	IPC - 01
0.2 - 1 bar (3 - 15 psi)	1.5 bar (23 psi)	IPC - 21
0.4 - 2 bar (6 - 30 psi)	2.5 bar (38 psi)	IPC - 42
0.2 - 3 bar (3 - 45 psi)	3.5 bar (53 psi)	IPC - 23
Other Pressure		On request

## Applications

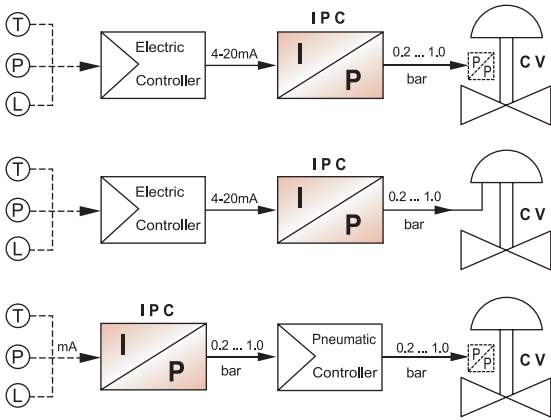

Ⓣ Temp. Transmitter Ⓟ Press. Transmitter Ⓛ Level Transmitter

IPC : I/P Converter, CV : Pneumatic Control Valve

## Board view

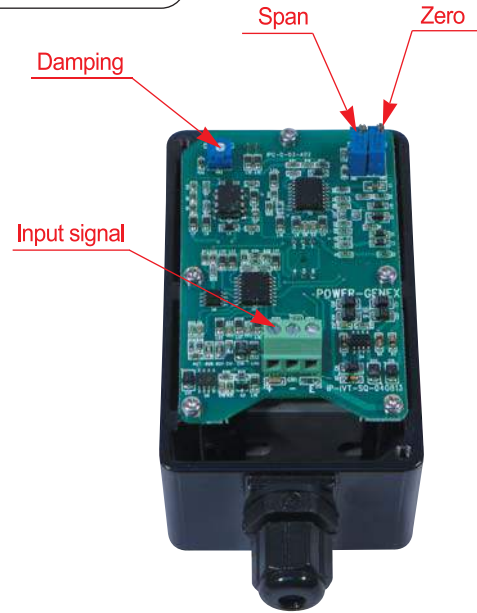

## Dimensions

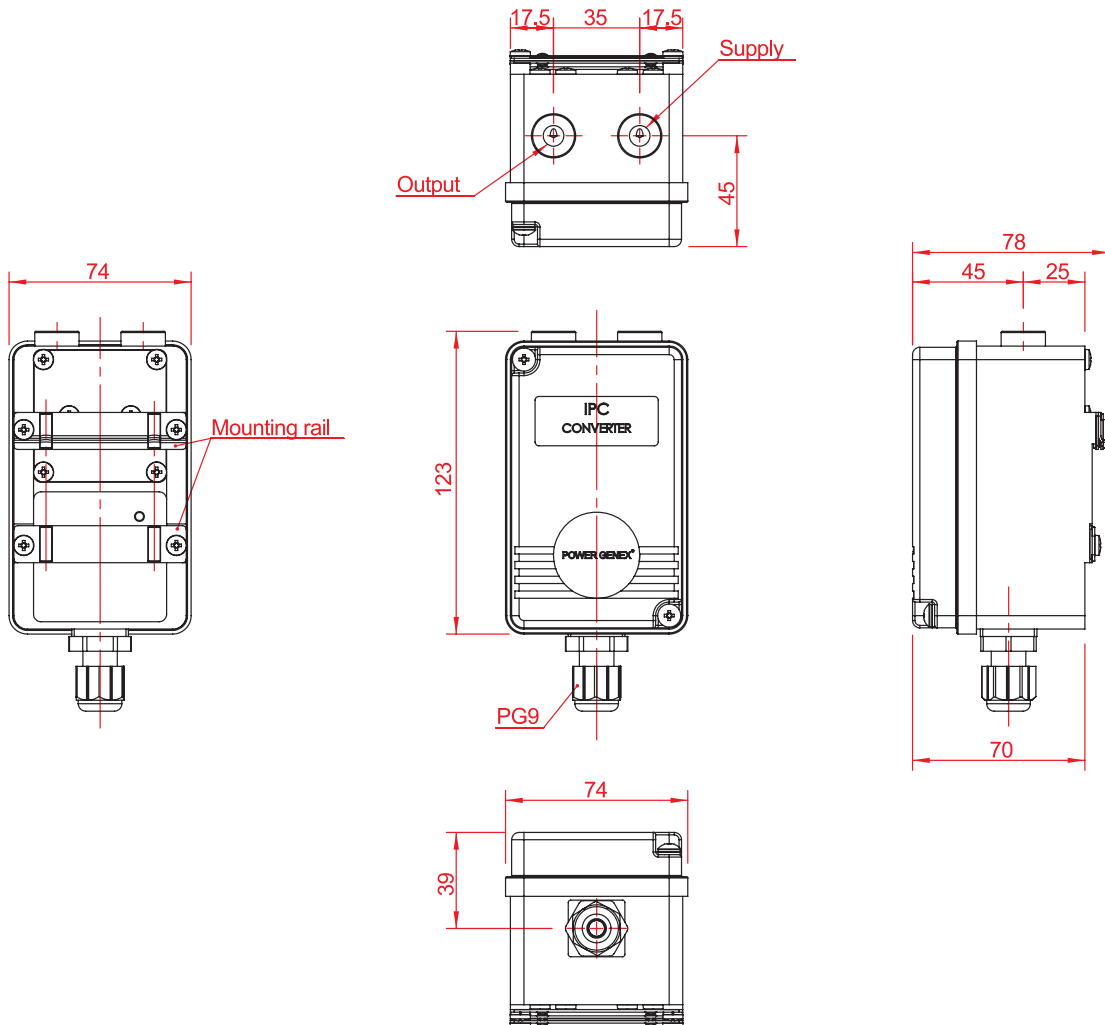



**Explosion proof position transmitter for reliable valve position feedback with 4-20mA output signal**

### Features

- ▶ Rugged aluminum die-cast housing
- ▶ Optional 2 x SPDT limit switch or 2 x P&F proximity sensor NJ2-V3-N

### Specifications

Model	PTP-L	PTP-R
Current Output Signal	4 - 20 mA, 2-wire	
Power Supply Range	12 - 30 VDC (24VDC recommendable)	
Span Adjustable Angle	10° - 45°	0° - 90°
Linearity	Within ± 1.0% F.S.	
Repeatability	Within ± 0.25% F.S.	
Hysteresis	Within 1.0% F.S.	
Operating Ambient Temperature	- 30 °C ~ +75 °C	
Explosion Proof Class	Ex d IIC T6	
Protection Class	IP66	
Electrical Connections	PF(G) 1/2 or NPT 1/2	
Weight	0.9 kg	

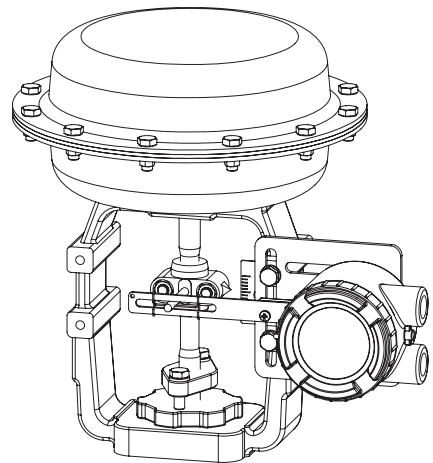

**PTP-L Mounting to Globe Control Valve**

### How to Order

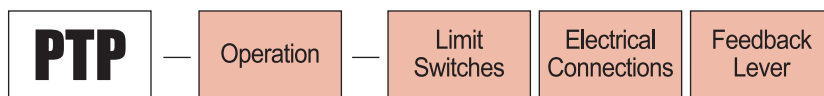

Description	Code
<b>Operation :</b>	L : Linear type R : Rotary type
<b>Limit Switches:</b>	N : None S : 2 x SPDT mechanical limit switch P : 2 x P&F proximity sensor NJ2-V3-N
<b>Electrical Connections:</b>	1 : PF(G) 1/2 2 : NPT 1/2
<b>Feedback Lever:</b> (only for linear type)	A : Stroke 10 - 40mm B : Stroke 10 - 80mm C : Stroke 80 - 150mm

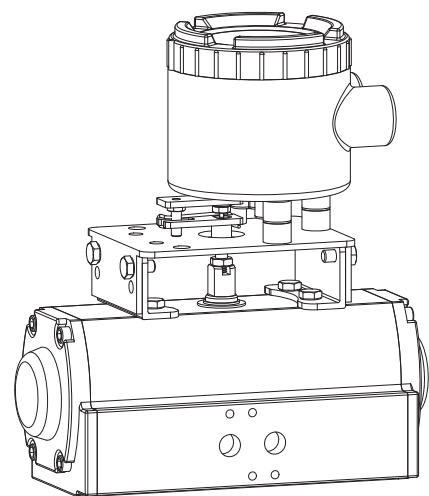

**PTP-R Mounting to Pneumatic Rotary Actuator**

Ex) PTP-L-S1A (linear type, 2 x SPDT, G 1/2, 10-40mm stroke)

## Measuring 4–20mA Output Signal

### 1) with mA calibrator

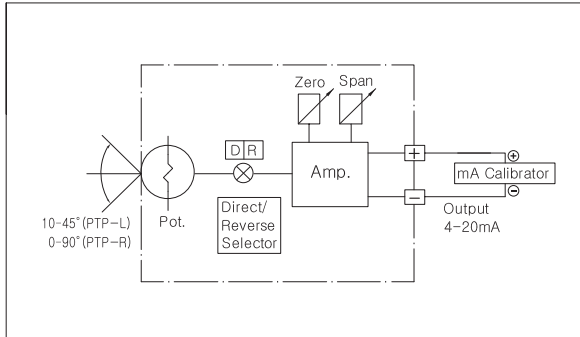

### 2) with multimeter

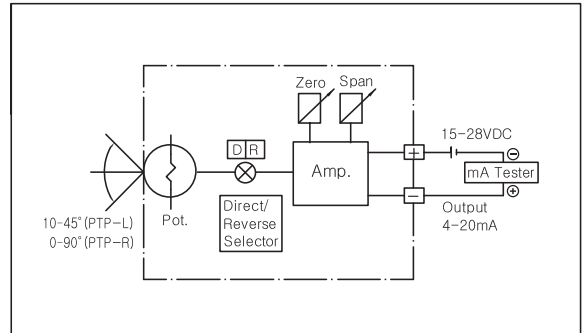

## Dimensions

### PTP-L (linear type)

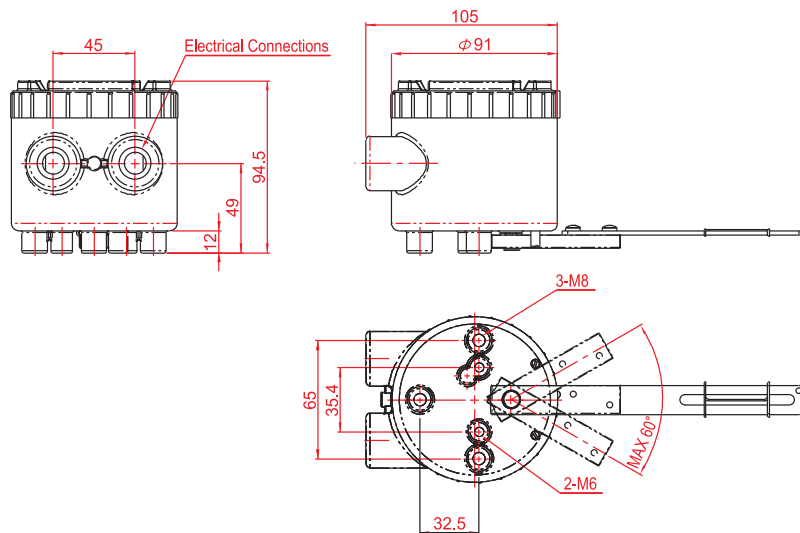

### PTP-R (rotary type)

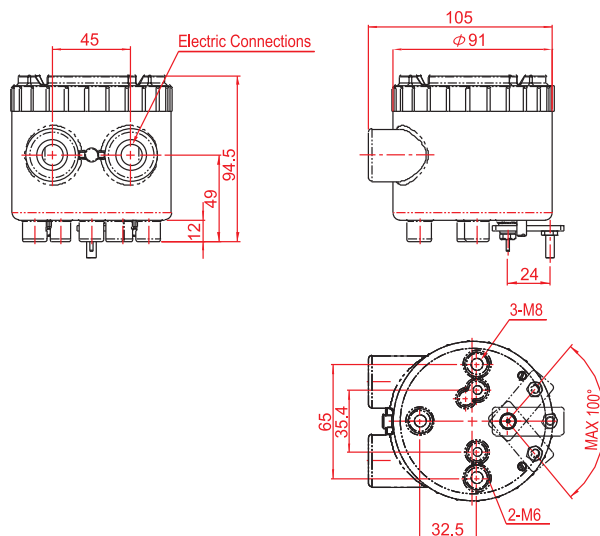



*Dependable safety valve to retain a set supply air pressure and guarantee a steady process control when a supply air is suddenly failed by accident and its pressure becomes lower than a set pressure*

## Specifications

	LU	
	LUS	LUD
Proof Pressure	Max 10 bar (150psi)	
Signal Pressure	1.4 ~ 7 bar	
Line Pressure	Max 7 bar (105psi)	
Flow Capacity (Cv)	0.9	
Operating Temperature	-20°C ~ +70°C	
Pneumatic Connections	PT(Rc) 1/4 or NPT 1/4	
Hysteresis	Within 0.1 bar	
Body Material	Aluminum die-cast / 316SS	
Weight	0.6 kg	0.8 kg

## How to Order

<b>LU</b>	Acting Type	Pneumatic Connections	Operating Temp.	Body Material

Description	Code
<b>Acting Type :</b>	S : Single acting D : Double acting
<b>Pneumatic Connections :</b>	1 : PT (Rc) 1/4 2 : NPT 1/4
<b>Operating Temperature :</b>	1 : -20 ~ +70°C (standard) 2 : -20 ~ +120°C (high temp.) 3 : -40 ~ +70°C (low temp.)
<b>Body Material :</b>	1 : Aluminum die-cast 2 : Stainless steel 316

## Dimensions

### < LUS >

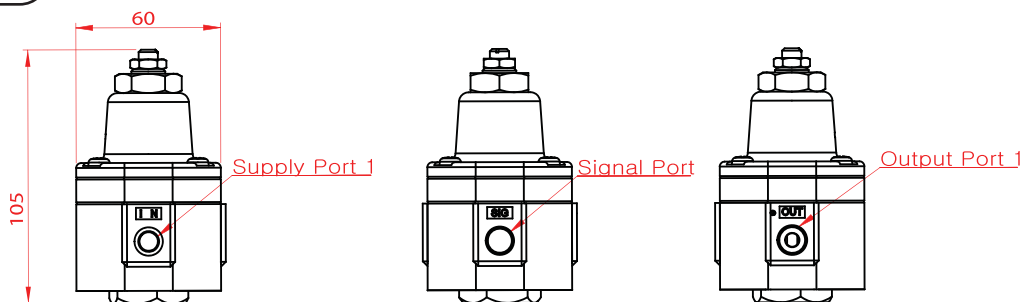

### < LUD >

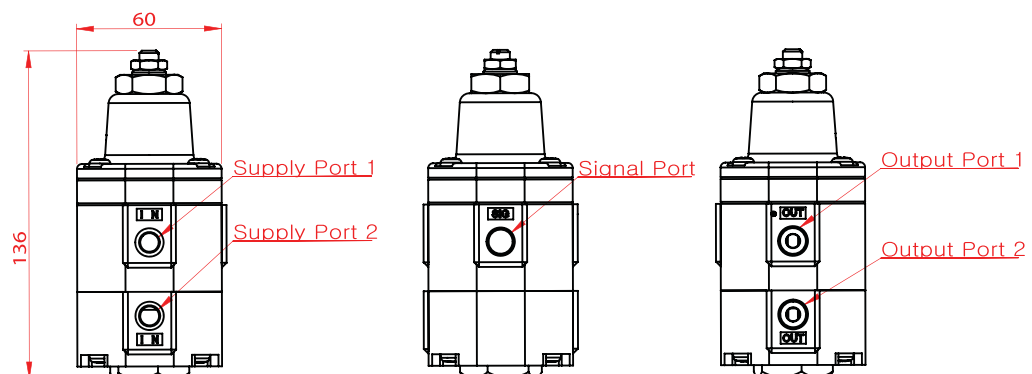





**Snap Acting Relay is the device which is usually used with an air tank, converts an air flow direction and moves the valve to the fail-safe position when the signal air pressure is lower than the set air pressure. Also, it has a fail-freeze function to help the valve stay at the last position on the loss of a supply air pressure.**

## Specifications

	SAR	
	Single	Double
Proof Pressure	Max 10 bar (150psi)	
Signal Pressure	1.4 ~ 7 bar	
Line Pressure	Max 7 bar (105psi)	
Flow Capacity (Cv)	0.9	
Operating Temperature	-20°C ~ +70°C (STD)	
Pneumatic Connections	NPT 1/4	
Hysteresis	Within 0.1 bar	
Body Material	Aluminum / 316SS	
Weight (Aluminum / 316SS)	0.6 kg / 1.2 kg	0.8 kg / 2.5 kg

## How to Order

<b>SAR</b> —	Material	Acting Type	Operating Temp.
--------------	----------	-------------	-----------------

Description	Code
Material :	10 : Aluminum 11 : 316SS
Acting Type :	0 : Single acting 1 : Double acting
Operating Temperature :	0 : -20 ~ +70°C (standard) 1 : -20 ~ +120°C (high temp.) 2 : -40 ~ +70°C (low temp.)

## Dimensions

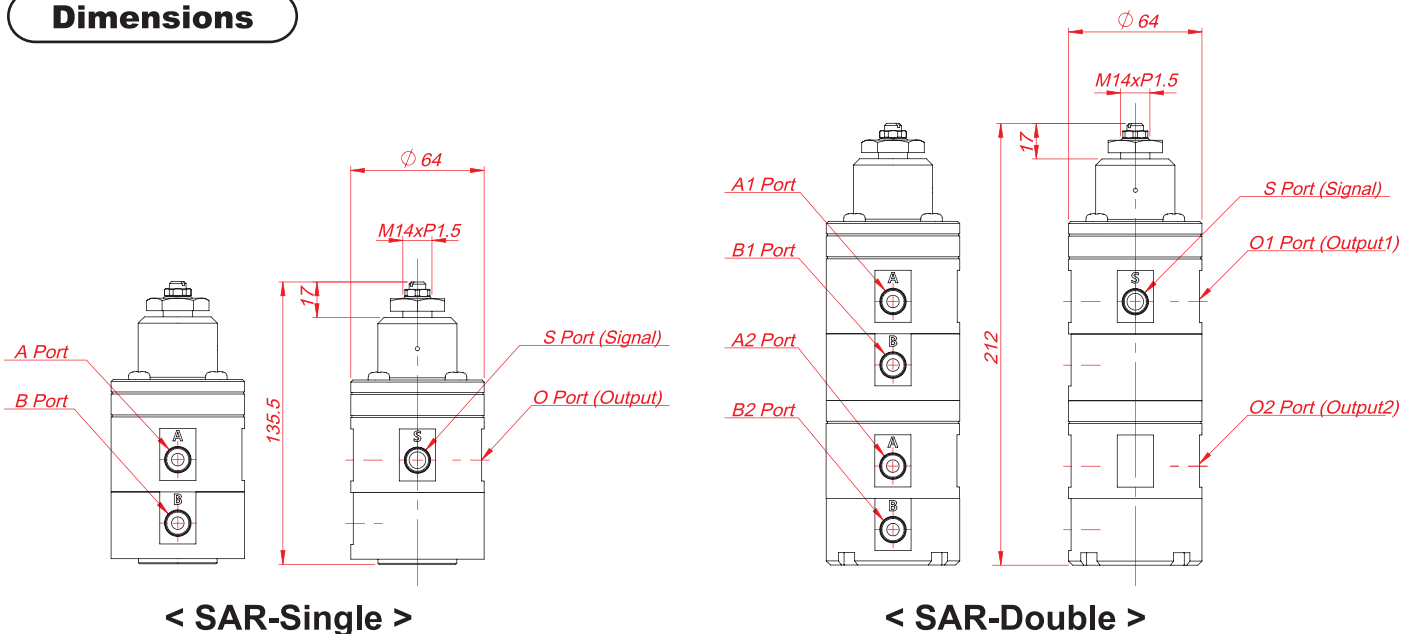

# Cylinder Applications

Consult with Power-Genex for the customized and optimized cylinder application



< With SS2 Positioner >

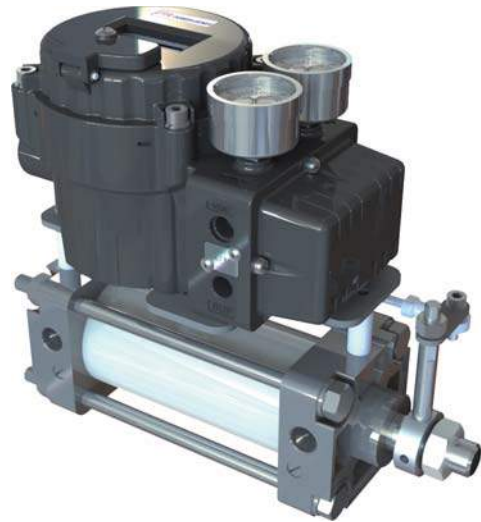

< With SS3 Positioner >

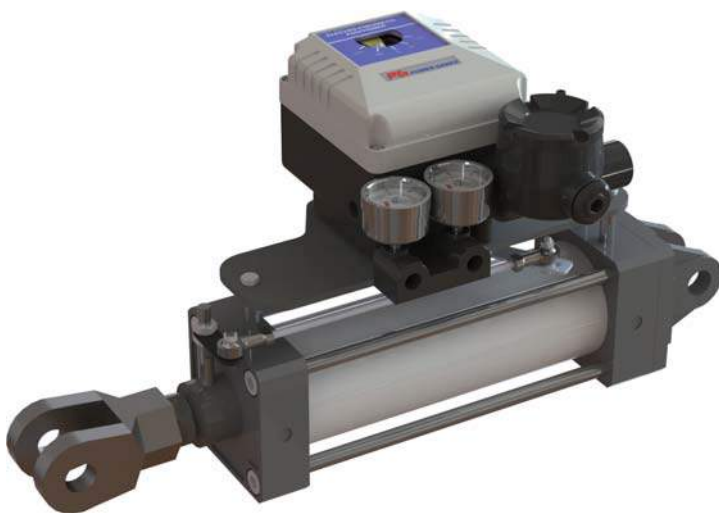

< With EPR Positioner >

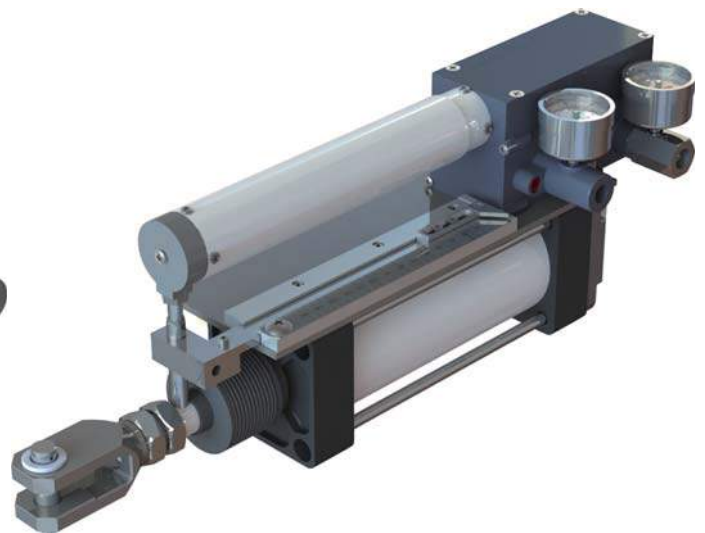

< With PPCL Positioner >

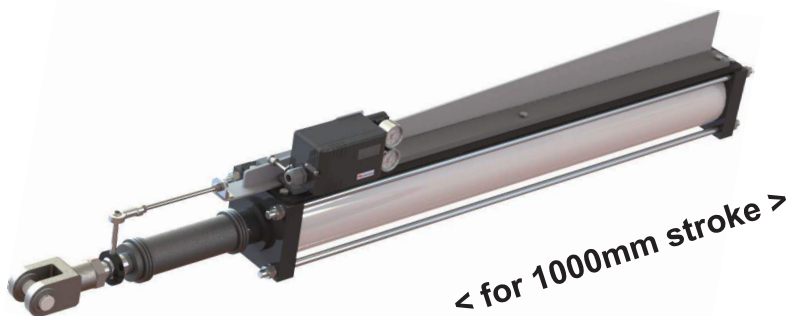

< for 1000mm stroke >

# Installations of Valve Accessories

## Linear Type

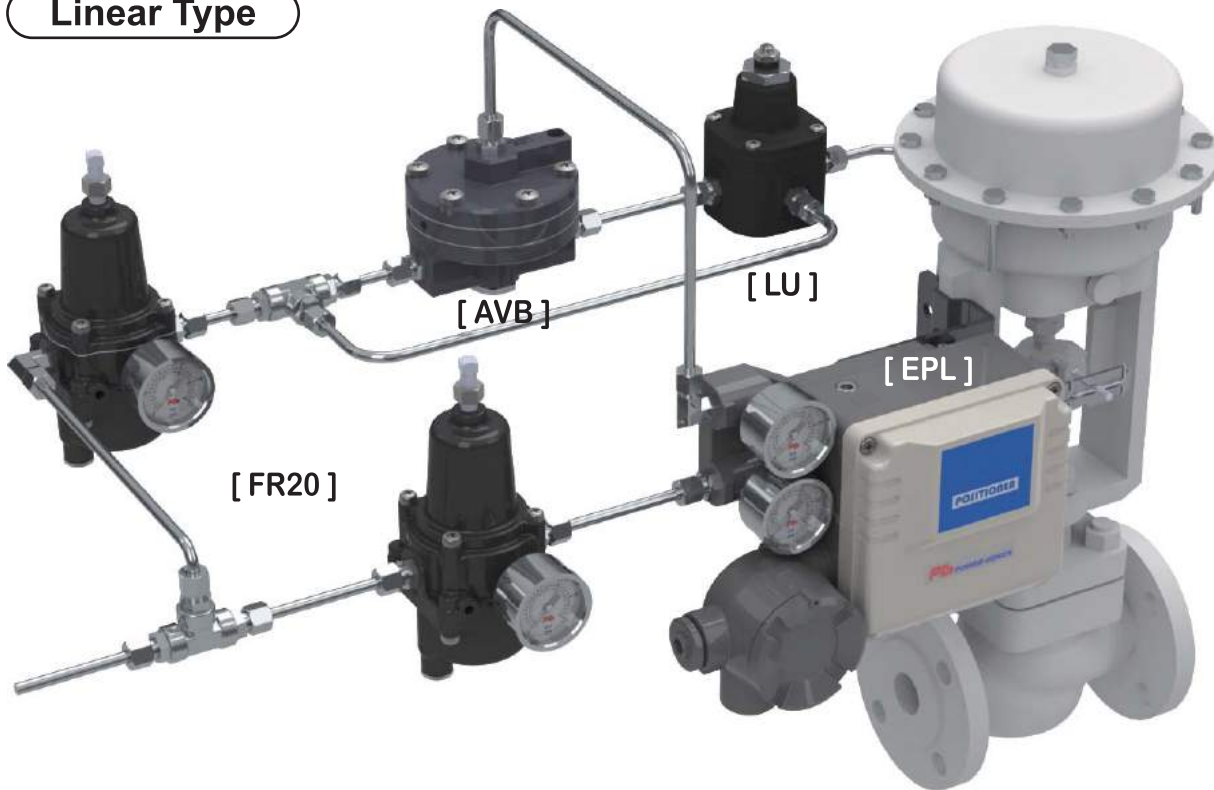

## Rotary Type

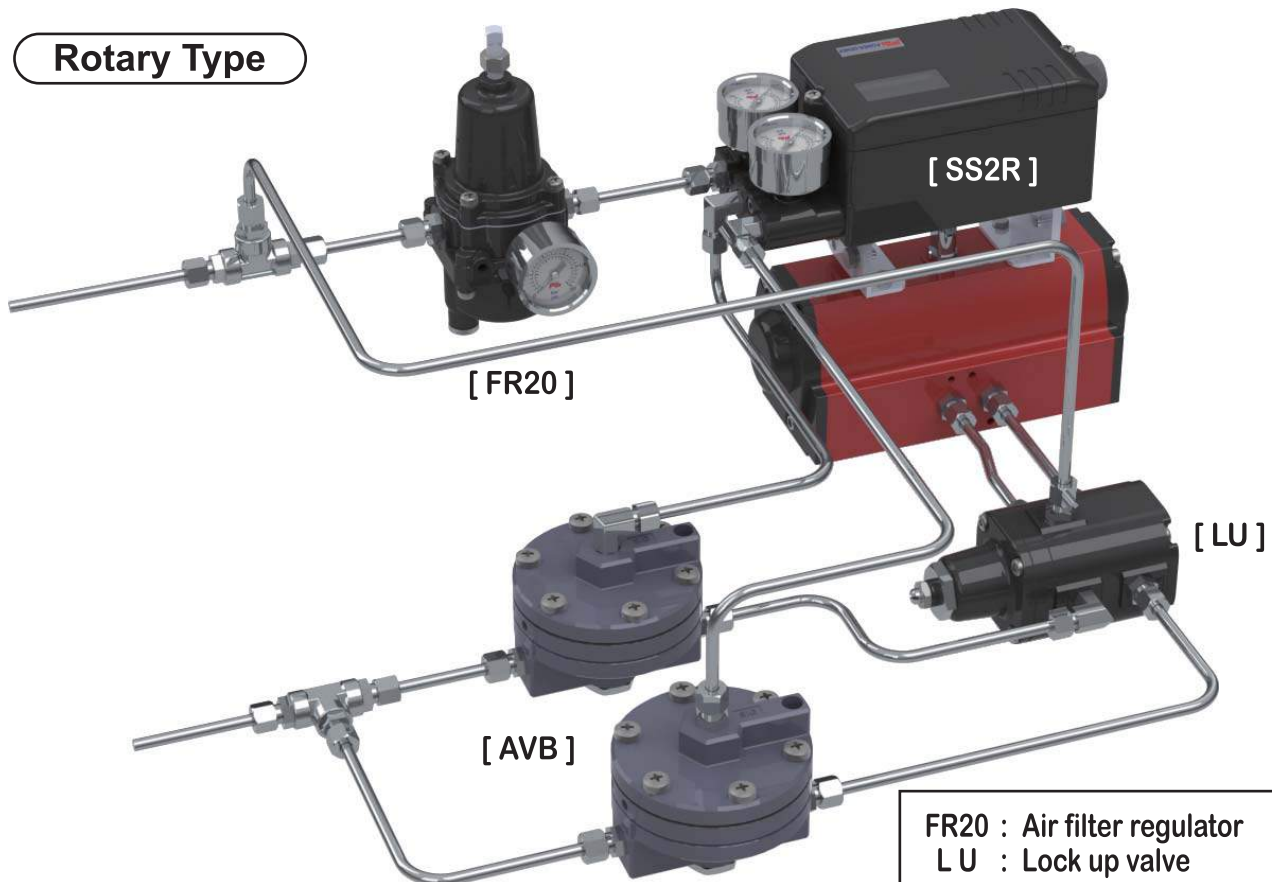

- FR20 : Air filter regulator
- LU : Lock up valve
- AVB : Air volume booster
- EP : Electro-pneumatic positioner
- SS2 : Smart valve positioner

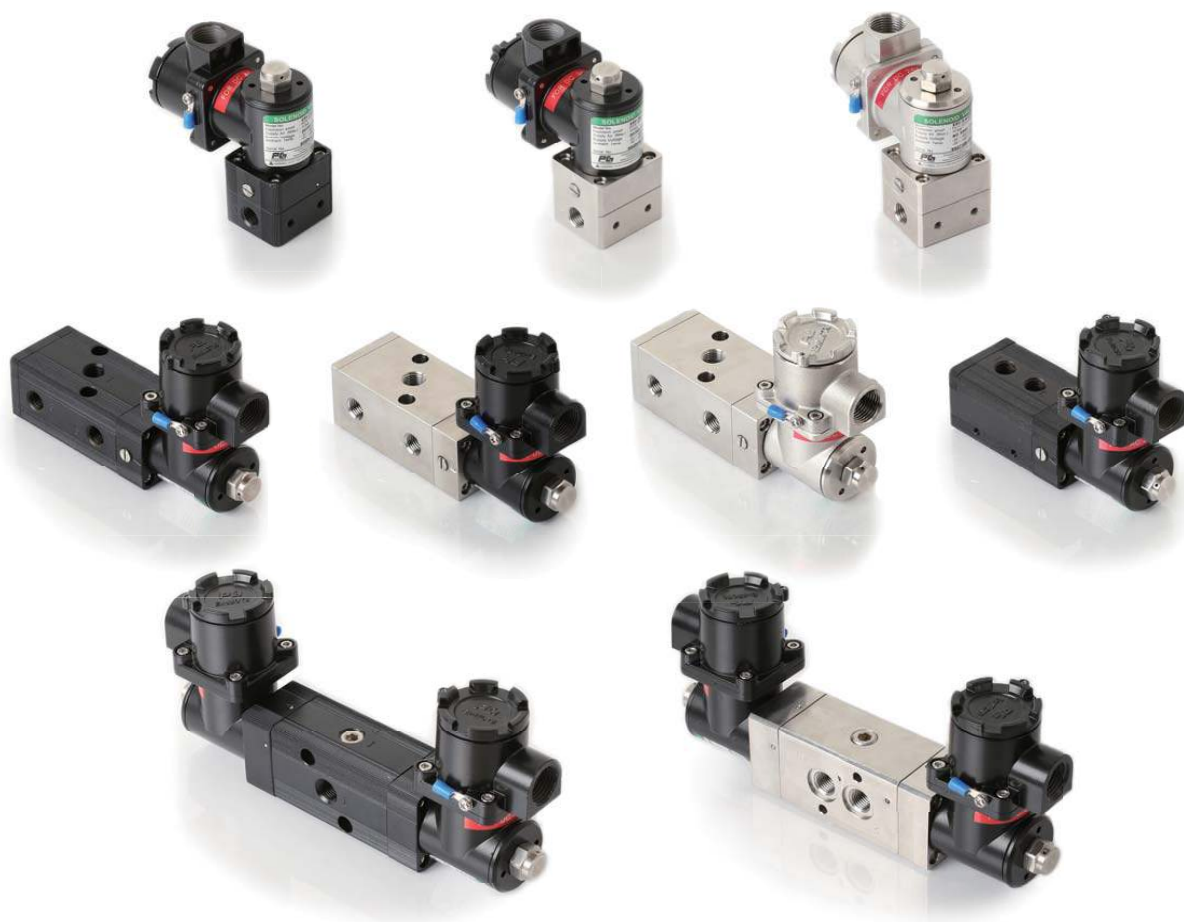

All innovation  
on driving your valve automation



## Solenoid Valve (5/2 way Cy 0 9) .



## Explosion proof solenoid valve for a confident control under rough working environments

### Features

- ▶ Rugged aluminum die-cast housing or Stainless steel 316
- ▶ Rotaable valve head for optimal mounting
- ▶ Direct NAMUR mounting or screw mounting
- ▶ Usable up to SIL3 acc. to IEC 61508
- ▶ KC - certified flameproof Ex d IIC T6 / T5
- ▶ NEPSI - certified flameproof Ex d IIC T6 / T5
- ▶ IECEX - certified flameproof Ex d IIC T6 / T5
- ▶ ATEX - certified flameproof Ex d IIC T6 / T5

### Specifications

Model	ESV-S	ESV-D
Operating Air Pressure	1.5 - 10 bar	
Air Supply (Max.)	15 bar	
Operating Voltage / Power	AC110V : 6.1VA / AC220V : 3.8VA / DC 24V : 3.4W	
Voltage Tolerance	10%	
Frequency	50Hz / 60Hz	
Explosion Proof Class	Ex d IIC T6 / T5, IP66	
Operating Ambient Temperature	T6 : -30 - +60 T5 : -30 - +80	
Flow Capacity(Cv)	0.9	
Mounting Configuration	NAMUR or screw interface	
Pneumatic Connections	PT(Rc) 1/4 or NPT 1/4	
Electrical Connection	PF(G) 1/2 or NPT 1/2	
Coil Insulation Grade	Class F / Class H	
Operating type	Single coil	Dual coil
Duty Cycle	100%	
Valve body material	Aluminum die-cast or Stainless steel 316	
Coil housing material	Aluminum die-cast or Stainless steel 316	
Weight (Valve body / Coil housing)	Aluminum / Aluminum : 0.9 kg Aluminum / SS316 : 1.9 kg SS316 / SS316 : 2.3 kg	Aluminum / Aluminum : 1.4 kg Aluminum / SS316 : 2.5 kg SS316 / SS316 : 3.3 kg

### Rotatable Valve Head

The ESV valve head can be rotated by 90° to the right or to the left for an optimal mounting as shown below

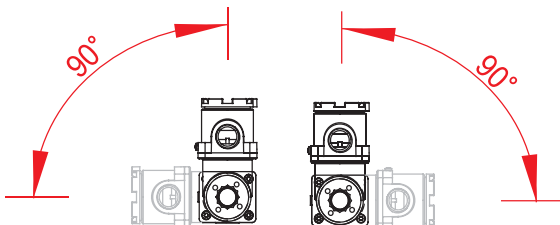

### Mounting

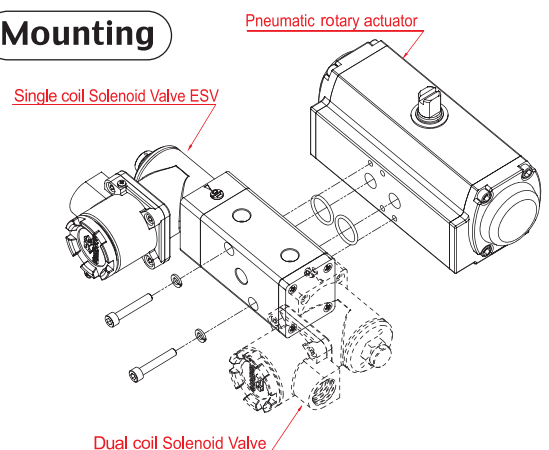



## Solenoid Valve (3/2 way, Cv 0.09)



## Explosion proof solenoid valve for a confident control under rough working environments

### Features

- ▶ Rugged aluminum die-cast housing or Stainless steel 316
- ▶ Rotatable valve head for optimal mounting
- ▶ Screw mounting
- ▶ Usable up to SIL3 acc. to IEC 61508
- ▶ KC - certified flameproof Ex d IIC T6 / T5
- ▶ NEPSI - certified flameproof Ex d IIC T6 / T5
- ▶ IECEX - certified flameproof Ex d IIC T6 / T5
- ▶ ATEX - certified flameproof Ex d IIC T6 / T5

### Specifications

Model	ESV-3	ESV-3S	ESV-3C
Orifice Size (Cv)		Ø 1.6 (0.09)	
Operating Air Pressure		1.5 - 7 bar	
Operating Voltage / Power	AC110V : 9.9VA / AC220V : 9.7VA / DC 24V : 4.8W		
Voltage Tolerance		10%	
Frequency		50Hz / 60Hz	
Explosion Proof Class		Ex d IIC T6 / T5, IP66	
Operating Ambient Temperature		T6 : -30 - +60 T5 : -30 - +80	
Flow Capacity		145 ℓ/min (6 bar)	
Mounting Configuration		Screw interface	
Pneumatic Connections	PT(Rc) 1/4 or NPT 1/4		NPT 1/4
Electrical Connection	PF(G) 1/2 or NPT 1/2		NPT 1/2
Coil Insulation Grade		Class F / Class H	
Duty Cycle		100%	
Valve body material	Aluminum	Stainless steel 316	Stainless steel 316
Coil housing material	Aluminum die-cast	Aluminum die-cast	Stainless steel 316
Weight	0.5 kg	0.8 kg	1.2 kg

### Rotatable Valve Head

The ESV valve head can be rotated by 90° to the right or to the left for an optimal mounting as shown below

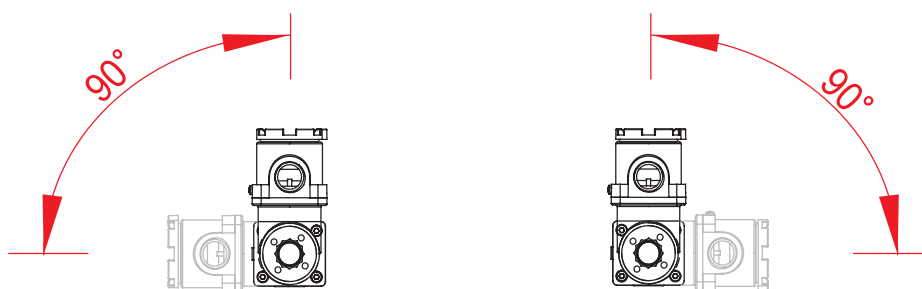

## Solenoid Valve (3/2 way, Cv 0.9)



## Explosion proof solenoid valve for a confident control under rough working environments

### Features

- ▶ Rugged aluminum die-cast housing or Stainless steel 316
- ▶ Rotatable valve head for optimal mounting
- ▶ Screw mounting
- ▶ Usable up to SIL3 acc. to IEC 61508
- ▶ KC - certified flameproof Ex d IIC T6 / T5
- ▶ NEPSI - certified flameproof Ex d IIC T6 / T5
- ▶ IECEX - certified flameproof Ex d IIC T6 / T5
- ▶ ATEX - certified flameproof Ex d IIC T6 / T5

### Specifications

Model	ESV-31	ESV-32
Operating Air Pressure	1.5 - 10 bar	
Air Supply (Max.)	15 bar	
Operating Voltage / Power	AC110V : 6.1VA / AC220V : 3.8VA / DC 24V : 3.4W	
Voltage Tolerance	10%	
Frequency	50Hz / 60Hz	
Explosion Proof Class	Ex d IIC T6 / T5, IP66	
Operating Ambient Temperature	T6 : -30 - +60 T5 : -30 - +80	
Flow Capacity(Cv)	0.9	
Mounting Configuration	Screw interface	
Pneumatic Connections	PT(Rc) 1/4 or NPT 1/4	
Electrical Connection	PF(G) 1/2 or NPT 1/2	
Coil Insulation Grade	Class F / Class H	
Operating type	Nomally - Closed	Nomally - Open
Duty Cycle	100%	
Valve body material	Aluminum die-cast or Stainless steel 316	
Coil housing material	Aluminum die-cast or Stainless steel 316	
Weight (Valve body / Coil housing)	Aluminum / Aluminum : 0.8 kg Aluminum / SS316 : 1.8 kg SS316 / SS316 : 2.1 kg	

### Rotatable Valve Head

The ESV valve head can be rotated by 90° to the right or to the left for an optimal mounting as shown below

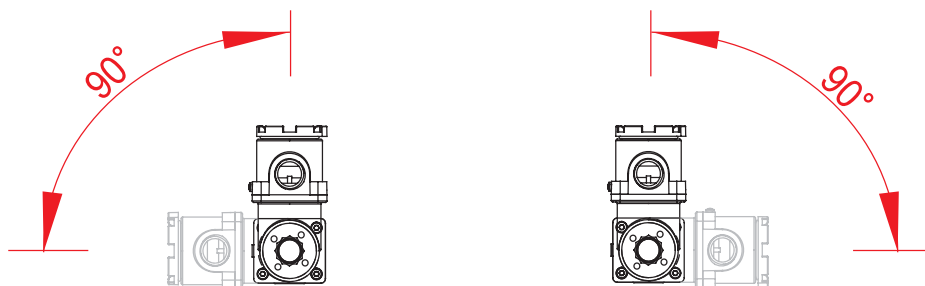

# Ordering Guide

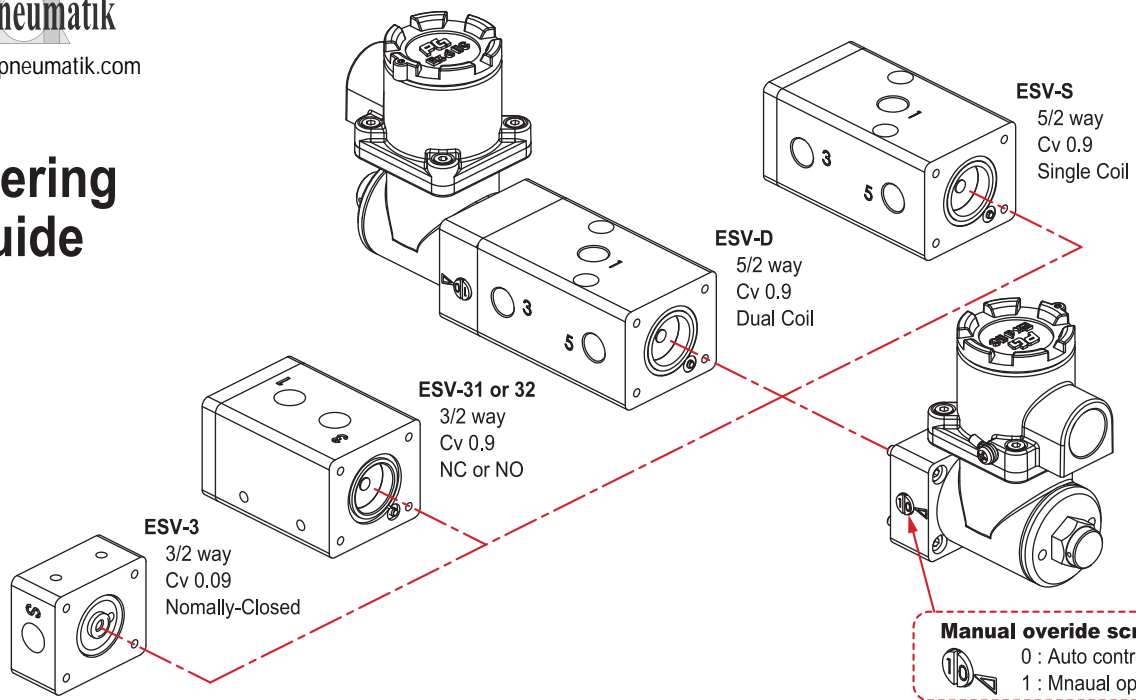

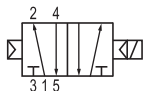
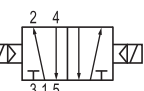
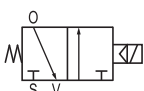
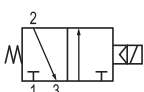
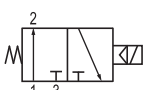
ESV Series	Operating Type	Body Material (valve body - coil housing)	Operating Voltage	Connections (pneumaitc - electrical)	Protection Class	Coil Class
<b>ESV</b>	<b>S</b>  5/2 way / Single Coil Cv 0.9	<b>Blank</b> Aluminum - Aluminum die-cast  <b>S</b> SS316 - Aluminum die-cast (only NPT 1/4 - NPT1/2 connections)  <b>C</b> SS316 - SS316 (only NPT 1/4 - NPT1/2 connections)	<b>A220</b> 220VAC  <b>A110</b> 110VAC  <b>D24</b> 24VDC	<b>P</b> PT 1/4 - PF 1/2  <b>N</b> NPT 1/4 - NPT 1/2  <b>M</b> PT 1/4 - M20x1.5	<b>Blank</b> KC Ex d IIC T6 / T5  <b>F</b> IECEx / ATEX Ex d IIC T6 / T5	<b>Blank</b> Class F  <b>H</b> Class H (only AC Voltage)
	<b>D</b>  5/2 way / Dual Coil Cv 0.9					
	<b>3</b>  5/2 way / N.C. Orifice 1.7					
	<b>31</b>  3/2 way / N.C. Cv 0.9					
	<b>32</b>  3/2 way / N.O. Cv 0.9					

Ex) **ESV - S - A220P** : 5/2 way single coil , Aluminum - aluminum die-cast , 220VAC , PT1/4-PF1/2 , KC Ex d IIC , Class F coil

## ESV-S

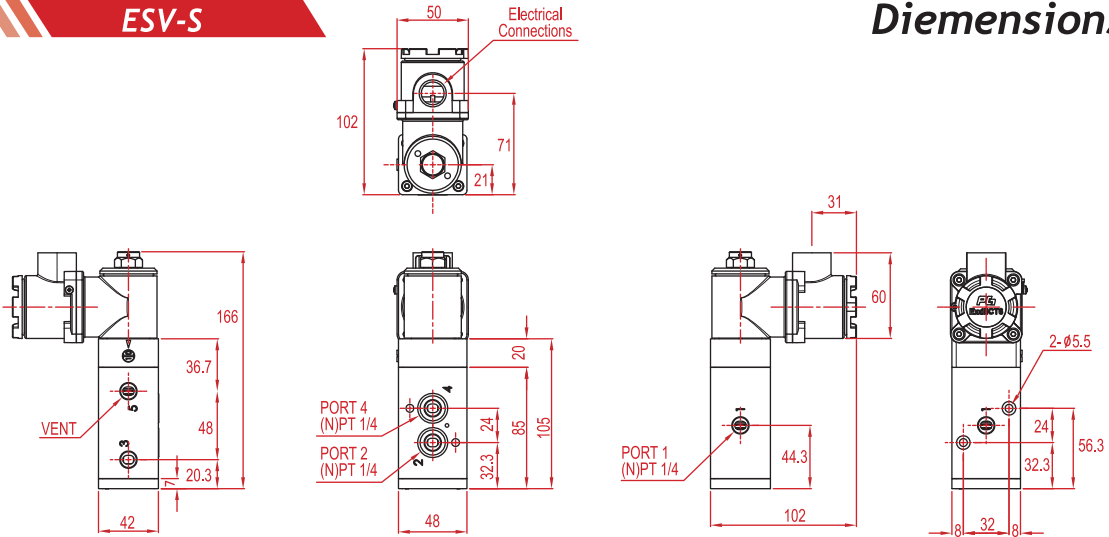

## Dimensions

## Symbol

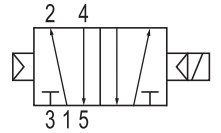

## ESV-D

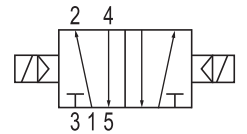
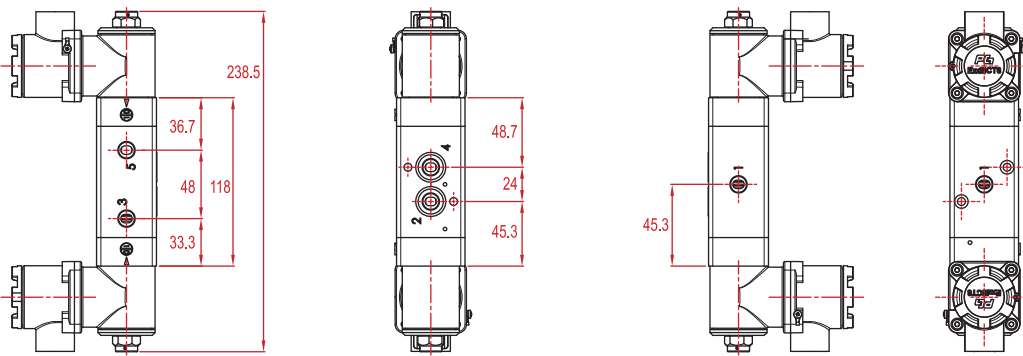

## ESV-31 / 32

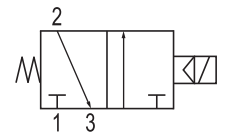
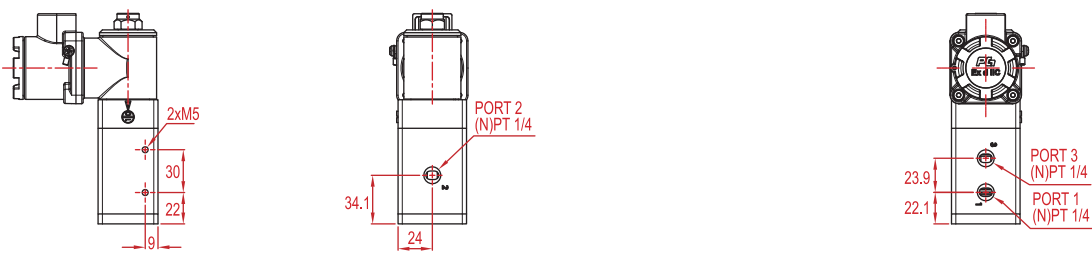

ESV-31  
< Normally - closed >

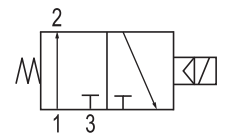

ESV-32  
< Normally - open >

## ESV-3

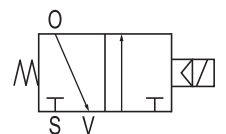
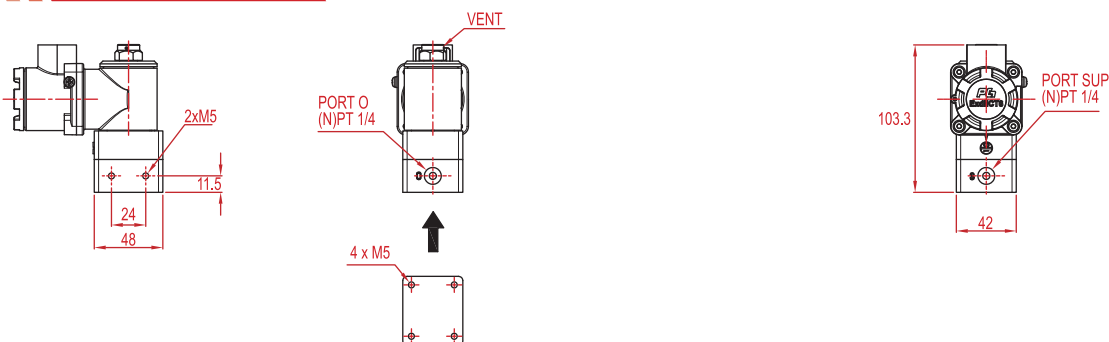

## Solenoid Valve (5/2 way, Cv 1.7)



### Weatherproof to IP65

- ▶ 5 port pilot / no lubrication
- ▶ Excellent durability
- ▶ Suitable for operation of even large-sized actuators with large effective section area of valve
- ▶ Suitable for PLC control system and computerized system due to a low power consumption
- ▶ Direct NAMUR mounting type

### Specifications

Model		ESV10 - S	ESV10 - D
Fluid		Air, Inert Gas	
Pneumatic Connections		PT(Rc) 1/4 / NPT 1/4 / PF(G) 1/4	
Electrical Connection(s)		PG9	
Effective Sectional Area(Cv)		31.2 mm <sup>2</sup> (1.7)	
Operating Pressure Range		1.5 - 9 bar	
Maximum Operating Frequency		5 cycle / sec.	
Operating (Response) Time		Less than 30ms	
Lubrication		Non-lubricant (if necessary, turbine oil ISO VG32 or equivalent recommended)	
Manual Operation		Non-lock push type	
Power	DC	2.8 W	
Consumption	AC	4.5 / 3.6VA (50 / 60Hz)	
Voltage Fluctuation Tolerance		± 10% of applicable voltage	
Operating Temperature		+5°C - +60°C	
Coil Insulation Class		Class F	
Protection Class		IP65	
Applicable Cylinder Size for Reference		Ø32 - Ø125	
Weight		330g	410g

### Mounting

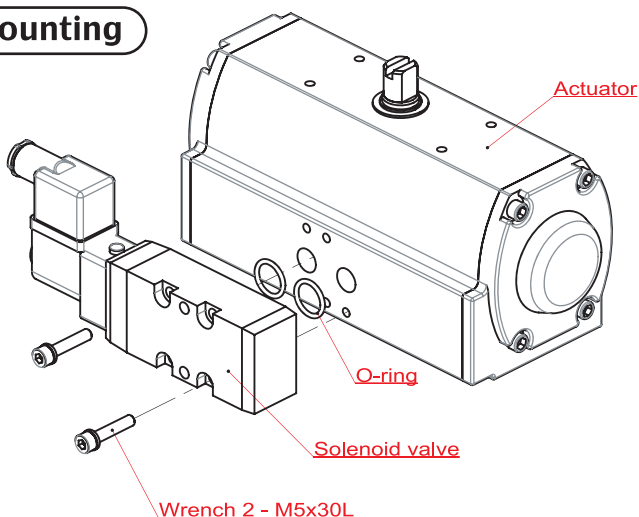



## Solenoid Valve (5/2 way, Cv 1.7)

### How to Order

# ESV10

Coil  
Type

Pneumatic  
Connections

Operating  
Voltage

Wiring  
Method

Description	Code	Description	Code
Coil type :	S : Single coil (return type) D : Dual coil (hold type)	Operating Voltage :	1 : AC 100/110V 50/60Hz 2 : AC 200/220V 50/60Hz 3 : DC 24V 4 : DC 12V 5 : DC 24V
Pneumatic Connections :	R : PT(Rc) 1/4 N : NPT 1/4 G : PF(G) 1/4	Wiring Method :	D : DIN connector Z : DIN connector with lamp and surge killer

### Symbol of Operation

Single Coil (return type)

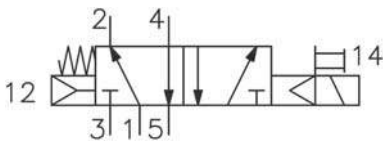

Dual Coil (hold type)

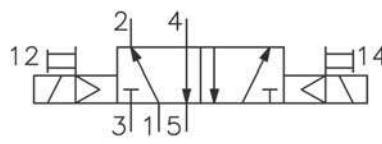

### Dimensions

#### Single Coil Type

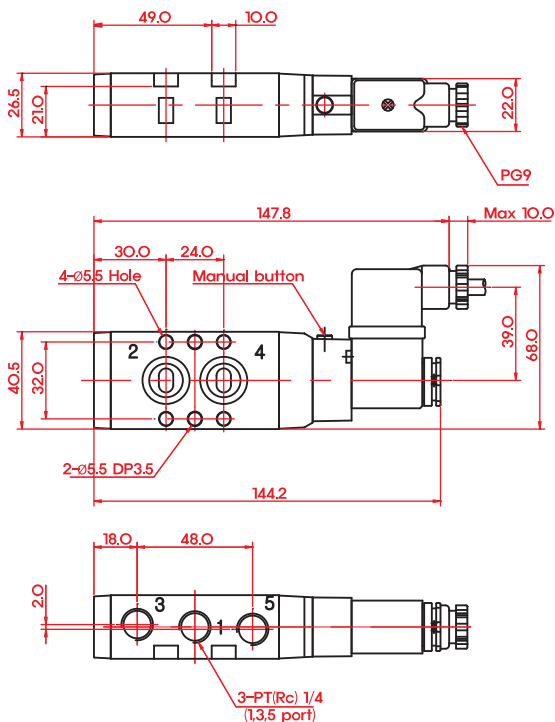

#### Dual Coil Type

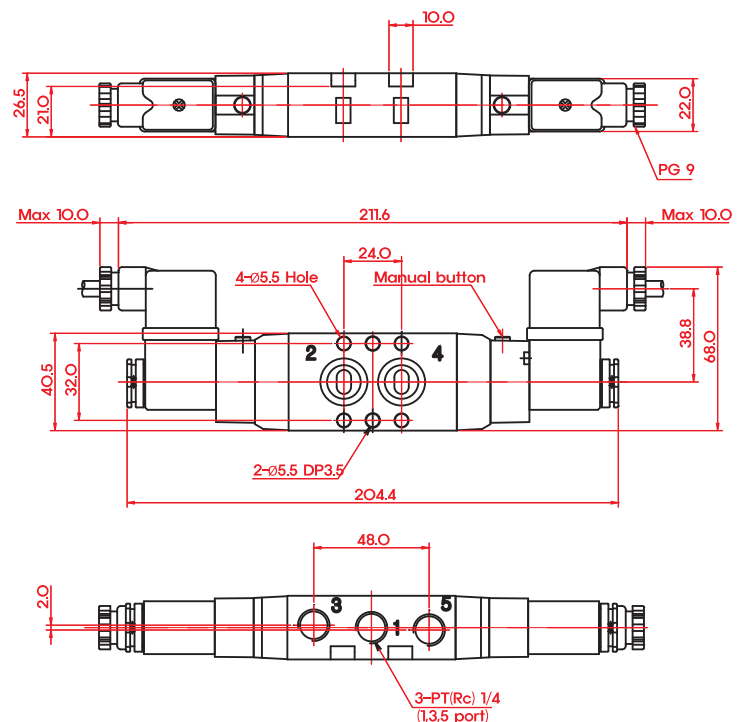



All-Technik Bldg. Lot 11 Block 36 San Antonio Avenue  
San Antonio Valley Sucat Parañaque City Philippines 1715  
Tel. No.: (+632) 8829-4849; 8829-4850; 8825-2563  
[www.alltechnik.com](http://www.alltechnik.com) [www.atpneumatik.com](http://www.atpneumatik.com)



www.atpneumatik.com

# FR Series Filter Regulator



All innovation  
on driving your valve automation



## Air Filter Regulator (with 1/4 ports)



**Valve air unit essential to provide clean and dry supply air to valve positioners, solenoid valves and pneumatic actuators**

### Features

- ▶ Rugged aluminum die-cast housing
- ▶ Optional stainless steel 316 housing
- ▶ Stable setting pressure
- ▶ High capacity with 5 micron filter
- ▶ Self-relief function to balance output and setting pressures
- ▶ High flow capacity

### Specifications

Model	FR-10	FR-11
Port Size	PT(Rc) 1/4 or NPT 1/4	NPT 1/4
Fluid	Air	
Output Pressure Range	0 - 4 bar (60 psi) / 0 - 8 bar (120 psi)	
Max. Supply Pressure	15 bar (225 psi)	
Operating and Fluid Temperature	-20°C to +70°C	
Supply Air	Filtered compressed, dry and non oiled air (up to 5 micron)	
Gauge Port Size	PT(Rc) 1/8	
Filteration	5 micron	
Housing Material	Aluminum die-cast	Stainless steel 316
Pressure Gauge Material	Stainless steel	
Weight	0.5 kg	1 kg

### Dimensions

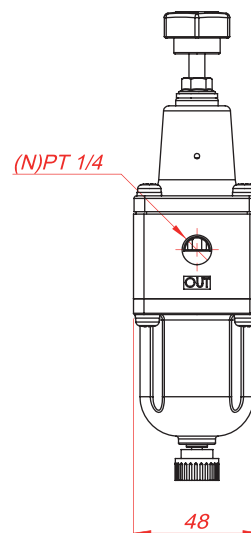
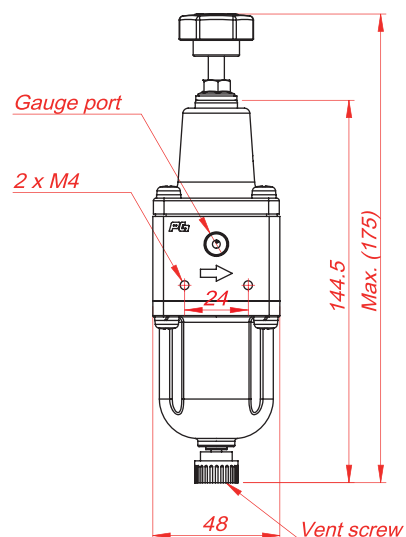

### How to Order

**FR** Body Material - Port Size Output Pressure Range

Description	Code
<b>Body Material</b>	10 : Aluminum die-cast 11 : Stainless steel 316
<b>Port Size</b>	R : PT(Rc) 1/4 N : NPT 1/4
<b>Output Pressure Range</b>	1 : 0 - 4 bar (60 psi) 2 : 0 - 8 bar (120 psi)

## Air Filter Regulator (with 1/4 ports)



**Valve air unit essential to provide clean and dry supply air to valve positioners, solenoid valves and pneumatic actuators**

### Features

- ▶ Rugged aluminum die-cast or stainless steel 316 housing
- ▶ Excellent stability and repeatability
- ▶ Outstanding sensitivity with precise setting
- ▶ High capacity with 5 micron filter
- ▶ Self-relief function to balance output and setting pressures
- ▶ High flow capacity
- ▶ Optional auto-drain (float type)

### Specifications

Model	FR-20	FR-21
Port Size	PT(Rc) 1/4 or NPT 1/4	NPT 1/4
Fluid	Air	
Output Pressure Range	0 - 4 bar (60 psi) / 0 - 8 bar (120 psi)	
Max. Supply Pressure	15 bar (225 psi)	
Operating and Fluid Temperature	-20°C to +70°C	
Supply Air	Filtered compressed, dry and non oiled air (up to 5 micron)	
Gauge Port Size	PT(Rc) 1/8	
Filtration	5 micron	
Housing Material	Aluminum die-cast	Stainless steel 316
Pressure Gauge Material	Stainless steel	
Weight	0.65 kg	1.4 kg

### Dimensions

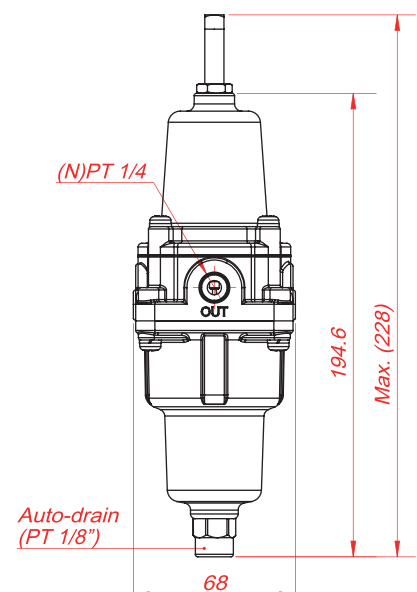
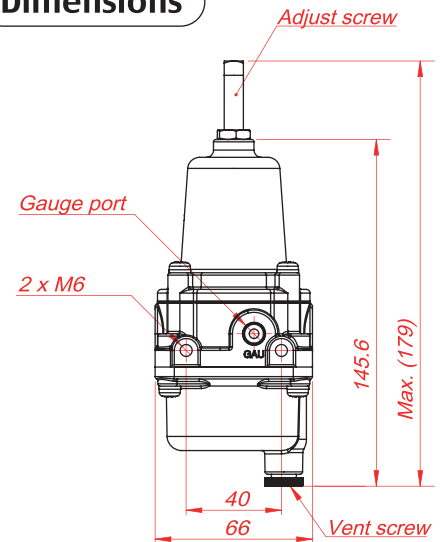

### How to Order

**FR** Body Material - Port Size Output Pressure Range Operating Temp. - Options

Description	Code	
Body Material	20 : Aluminum die-cast 21 : Stainless steel 316	
Port Size	R : PT(Rc) 1/4	N : NPT 1/4
Output Pressure Range	1 : 0 - 4 bar (60 psi)	2 : 0 - 8 bar (120 psi)
Operating Temperature	0 : -20 - +70 °C 2 : -40 - +80 °C	1 : -20 - +120 °C
Options	M : Manual drain	A : Auto drain



## Air Filter Regulator (with 1/2 or 3/4 ports)



**Valve air unit essential to provide clean and dry supply air to valve positioners, solenoid valves and pneumatic actuators**

### Features

- ▶ Rugged aluminum die-cast or stainless steel 316 housing
- ▶ Excellent stability and repeatability
- ▶ Outstanding sensitivity with precise setting
- ▶ High capacity with 5 micron filter
- ▶ Self-relief function to balance output and setting pressures
- ▶ High flow capacity
- ▶ Optional auto-drain (float type)

### Specifications

Model	FR-30	FR-31
Port Size	PT(Rc) 1/2, NPT 1/2 PT(Rc) 3/4, NPT 3/4	NPT 1/2 NPT 3/4
Fluid	Air	
Output Pressure Range	0 - 4 bar (60 psi) / 0 - 8 bar (120 psi)	
Max. Supply Pressure	15 bar (225 psi)	
Operating Temperature	-20°C to +70°C	
Supply Air	Filtered compressed, dry and non oiled air (up to 5 micron)	
Gauge Port Size	PT(Rc) 1/8	
Filtration	5 micron	
Housing Material	Aluminum die-cast	Stainless steel 316
Pressure Gauge Material	Stainless steel	
Weight	1.6 kg	3.4 kg

### Dimensions

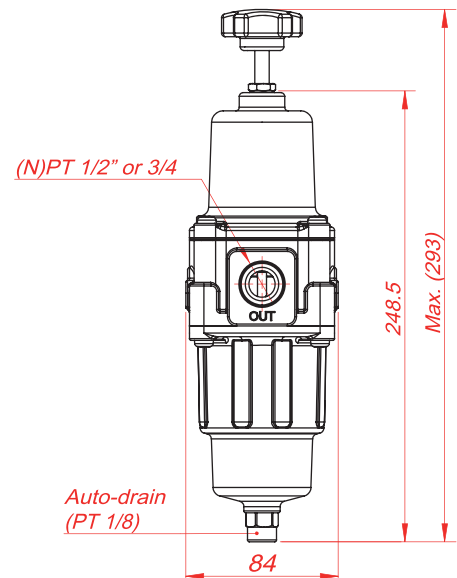
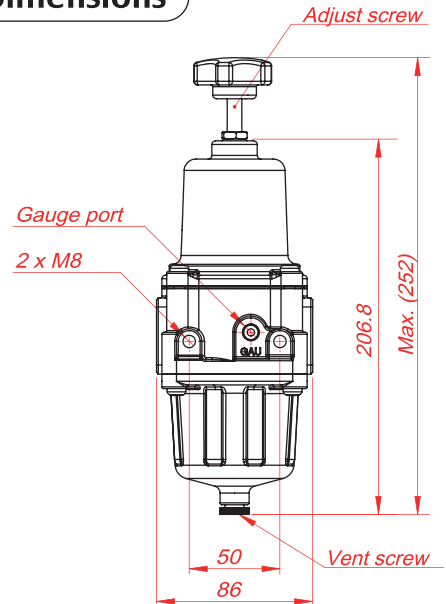

### How to Order

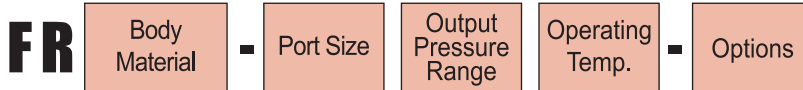

Description	Code	
Body Material	30 : Aluminum die-cast 31 : Stainless steel 316	
Port Size	1 : PT (Rc) 1/2 3 : PT (Rc) 3/4	2 : NPT 1/2 4 : NPT 3/4
Output Pressure Range	1 : 0 - 4 bar (60 psi)	2 : 0 - 8 bar (120 psi)
Operating Temperature	0 : -20 - +70°C 2 : -40 - +80°C	1 : -20 - +120°C
Options	M : Manual drain	A : Auto drain



All-Technik Bldg. Lot 11 Block 36 San Antonio Avenue  
San Antonio Valley Sucat Parañaque City Philippines 1715  
Tel. No.: (+632) 8829-4849; 8829-4850; 8825-2563  
[www.alltechnik.com](http://www.alltechnik.com) [www.atpneumatik.com](http://www.atpneumatik.com)

# AVB Series Air Volume Booster



All innovation  
on driving your valve automation



## Air Volume Booster (with 1/4 or 3/8 ports)



< AVB-1000 > CE Ex II2 G/D



< AVB-1100 > CE Ex II2 G/D

The AVB-1000 series is mounted between the positioner and actuator. It provides the actuator with a high air flow output whose pressure corresponds exactly to the signal pressure

### Features

- ▶ Delivers high air volume to actuator rapidly
- ▶ Tunes a unit response to eliminate an actuator overshoot or overdamping
- ▶ Provides a tight shut off to reduce a costly air consumption
- ▶ Optional 1/4 or 3/8, PT or NPT supply and output ports

### Options

- ▶ High temperature : -20°C - +120°C
- ▶ Low temperature : -40°C - +80°C

### How to Order

## AVB - 1

Body Material

Port Size

Operating Temp.

Description	Code
Body Material :	0 : Aluminum die-cast 1 : Stainless steel 316
Port Size :	0 : PT (Rc) 1/4 1 : NPT 1/4 2 : PT (Rc) 3/8 3 : NPT 3/8
Operating Temperature :	0 : -20 ~ +80°C (standard) 1 : -20 ~ +120°C (high temp.) 2 : -40 ~ +80°C (low temp.)

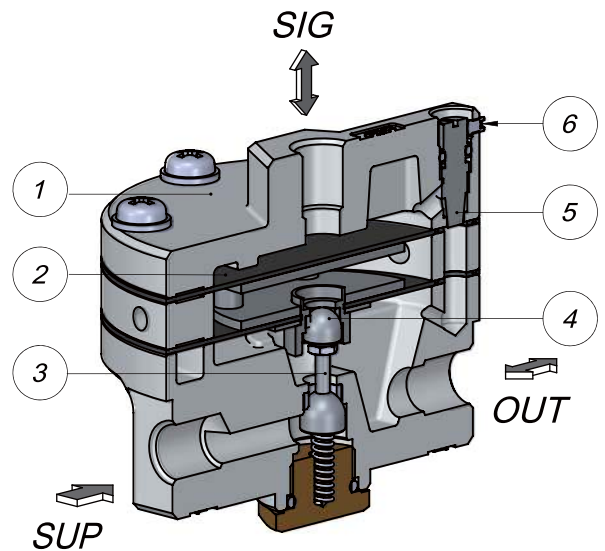

< Sectional View of AVB-1000 >

No.	Description	AVB-1000	AVB-1100
1	Body	ALDC 12.1	SS316
2	Diaphragm	N.B.R	N.B.R
3	Inlet valve	SS304	SS316
4	Exhaust valve	SS304	SS316
5	Adjusting screw	SS304	SS316
6	Lock screw	SS304	SS316

# AVB-1000 Series

## Specifications

Model	AVB-1000	AVB-1100
<b>Conditions of Supply Air</b>		
Supply Air Pressure	Max. 10 bar (150 psi)	
Signal Air Pressure (positioner output)	Max. 7 bar (105 psi)	
Supply Air Quality acc. to ISO 8573-1	Filtered, compressed dry and non-oiled to meet Class 3	
<b>Closed Loop Control</b>		
Pressure Ratio : signal to output	1 : 1	
Dead Band	2% (0.016 bar)	
Hysteresis	1 %	
Linearity	±1% F.S	
<b>Flow Cv</b>		
Supply Cv	1.2	
Exhaust Cv	1.1	
<b>Other Operating Parameters</b>		
Operating Ambient Temperature	-20 ~ +80°C (std), -20 ~ +120°C (high), -40 ~ +80°C (low)	
Weight	0.56 kg	1.2 kg
<b>Connecting Port Threads</b>		
Supply (SUP) / Output (OUT)	PT 1/4, NPT 1/4, PT 3/8, NPT 3/8	NPT 1/4, NPT 3/8
Signal (SIG)	PT 1/4, NPT 1/4	NPT 1/4
<b>Materials</b>		
Body	Aluminum die-cast	Stainless steel 316
Diaphragm	NBR	
O-rings	NBR	
<b>Protection Class</b>		
Explosion-proof	CE  II2 G/D	

## Dimensions

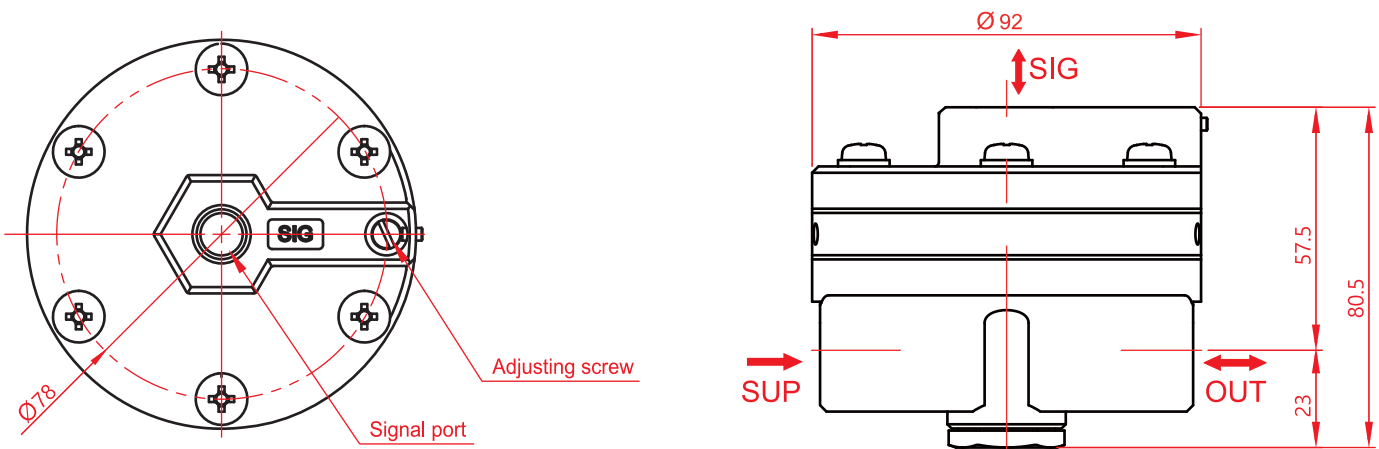



## Air Volume Booster (with 1/2 ports)

The AVB-2000 series is the heavy-duty volume booster relays with bigger ports and a more flow capacity to help a large actuator move faster by converting a low flow control signal to the higher flow



< AVB-2000 > CE Ex II2 G/D



< AVB-2100 > CE Ex II2 G/D



### Features

- ▶ Delivers a high air volume for a fast actuator movement
- ▶ Tunes a unit response to eliminate an actuator overshoot or overdamping
- ▶ Provides a tight shut off to reduce a costly air consumption
- ▶ Available in aluminum or stainless steel 316
- ▶ Exhaust filters are installed for prevention of contamination by foreign substances from outside

### Options

- ▶ NPT 1/2 threaded exhaust ports
- ▶ Supply pressure gauge port
- ▶ High temperature : -20°C - +120°C
- ▶ Low temperature : -40°C - +80°C

### How to Order

**AVB - 2** Body Material Port Size Operating Temp. - Options

Description	Code
Body Material :	0 : Aluminum die-cast 1 : Stainless steel 316
Port Size :	0 : PT (Rc) 1/2 1 : NPT 1/2
Operating Temperature :	0 : -20 ~ +80°C (standard) 1 : -20 ~ +120°C (high temp.) 2 : -40 ~ +80°C (low temp.)
Options :	N : None A : Supply pressure gauge port B : NPT 1/2 threaded exhaust port C : A + B

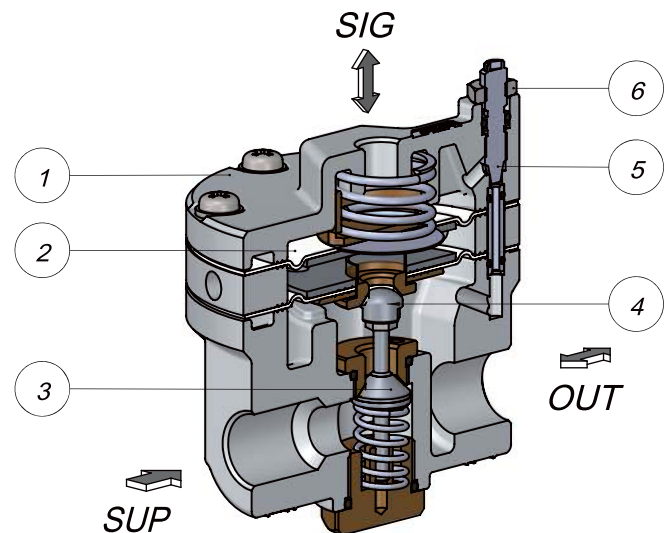

< Sectional View of AVB-2000 >

No.	Description	AVB-2000	AVB-2100
1	Body	ALDC 12.1	SS316
2	Diaphragm	N.B.R	N.B.R
3	Inlet valve	SS304	SS316
4	Exhaust valve	SS304	SS316
5	Adjusting screw	SS304	SS316
6	Lock nut	SS304	SS316

# AVB-2000 Series

## Specifications

Model	AVB-2000	AVB-2100
<b>Conditions of Supply Air</b>		
Supply Air Pressure	Max. 10 bar (150 psi)	
Signal Air Pressure (positioner output)	Max. 7 bar (105 psi)	
Supply Air Quality acc. to ISO 8573-1	Filtered, compressed dry and non-oiled to meet Class 3	
<b>Closed Loop Control</b>		
Pressure Ratio : signal to output	1 : 1	
Dead Band	2% (0.016 bar)	
Hysteresis	1 %	
Linearity	±1% F.S	
<b>Flow Cv</b>		
Supply Cv	3.1	
Exhaust Cv	2.4	
<b>Other Operating Parameters</b>		
Operating Ambient Temperature	-20 ~ +80°C (std), -20 ~ +120°C (high), -40 ~ +80°C (low)	
Weight	1.0 kg	2.4 kg
<b>Connecting Port Threads</b>		
Supply (SUP) / Output (OUT)	PT 1/2 or NPT 1/2	NPT 1/2
Signal (SIG)	PT 1/4 or NPT 1/4	NPT 1/4
<b>Materials</b>		
Body	Aluminum die-cast	Stainless steel 316
Diaphragm	NBR (std)	
O-rings	NBR (std)	
<b>Protection Class</b>		
Explosion-proof	CE  II 2 G/D	

## Dimensions

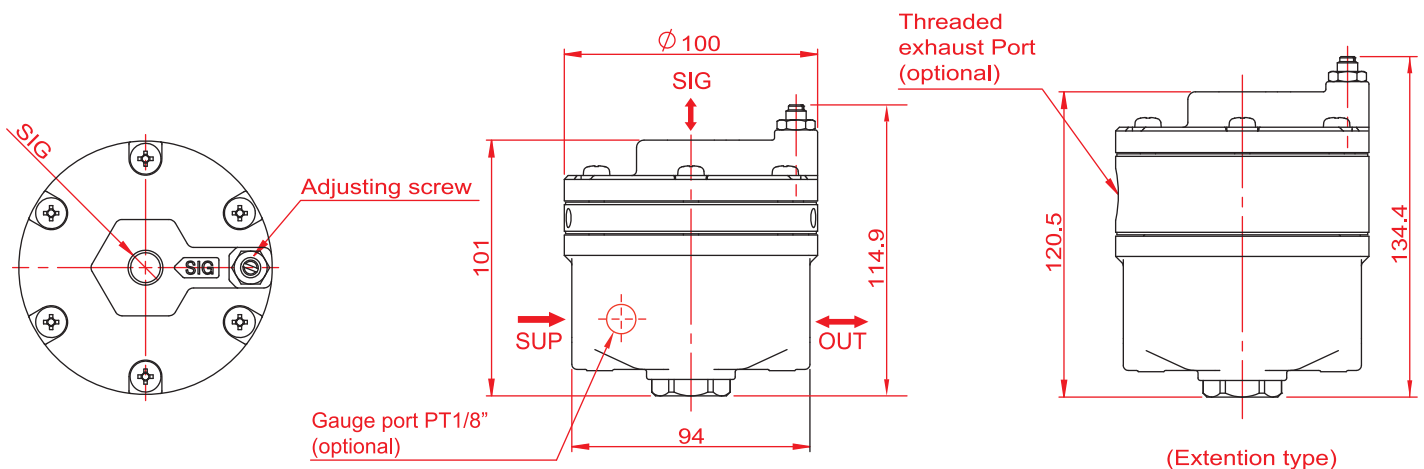

## Air Volume Booster (with 3/4 ports)



< AVB-3000 > CE Ex II2 G/D



The AVB-3000 series is the heavy-duty volume booster relays with bigger ports and a more flow capacity to help a large actuator move faster by converting a low flow control signal to the higher flow

### Features

- ▶ Delivers a high air volume for a fast actuator movement
- ▶ Tunes a unit response to eliminate an actuator overshoot or overdamping
- ▶ Provides a tight shut off to reduce a costly air consumption
- ▶ Available in aluminum or stainless steel 316
- ▶ Exhaust filters are installed for prevention of contamination by foreign substances from outside

### Options

- ▶ NPT 1/2 threaded exhaust ports
- ▶ Supply pressure gauge port
- ▶ High temperature : -20°C - +120°C
- ▶ Low temperature : -40°C - +80°C



< AVB-3100 > CE Ex II2 G/D

### How to Order

**AVB - 3** Body Material Port Size Operating Temp. - Options

Description	Code
Body Material :	0 : Aluminum die-cast 1 : Stainless steel 316
Port Size :	0 : PT (Rc) 3/4 1 : NPT 3/4
Operating Temperature :	0 : -20 ~ +80°C (standard) 1 : -20 ~ +120°C (high temp.) 2 : -40 ~ +80°C (low temp.)
Options :	N : None A : Supply pressure gauge port B : NPT 1/2 threaded exhaust port C : A + B

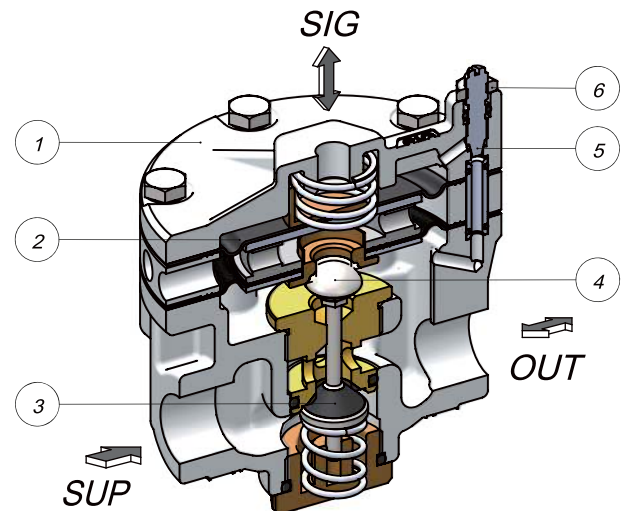

< Sectional View of AVB-3000 >

No.	Description	AVB-3000	AVB-3100
1	Body	ALDC 12.1	SS316
2	Diaphragm	N.B.R	N.B.R
3	Inlet valve	SS304	SS316
4	Exhaust valve	SS304	SS316
5	Adjusting screw	SS304	SS316
6	Lock nut	SS304	SS316

# AVB-3000 Series

## Specifications

Model	AVB-3000	AVB-3100
<b>Conditions of Supply Air</b>		
Supply Air Pressure	Max. 10 bar (150 psi)	
Signal Air Pressure (positioner output)	Max. 7 bar (105 psi)	
Supply Air Quality acc. to ISO 8573-1	Filtered, compressed dry and non oiled to meet Class 3	
<b>Closed Loop Control</b>		
Pressure Ratio : signal to output	1 : 1	
Dead Band	2% (0.016 bar)	
Hysteresis	1 %	
Linearity	±1% F.S	
<b>Flow Cv</b>		
Supply Cv	5.1	
Exhaust Cv	5.1	
<b>Other Operating Parameters</b>		
Operating Ambient Temperature	-20 ~ +80°C (std), -20 ~ +120°C (high), -40 ~ +80°C (low)	
Weight	2.0 kg	4.3 kg
<b>Connecting Port Threads</b>		
Supply (SUP) / Output (OUT)	PT 3/4 or NPT 3/4	NPT 3/4
Signal (SIG)	PT 1/4 or NPT 1/4	NPT 1/4
<b>Materials</b>		
Body	Aluminum die-cast	Stainless steel 316
Diaphragm	NBR (std)	
O-rings	NBR (std)	
<b>Protection Class</b>		
Explosion-proof	CE  II 2 G/D	

## Dimensions

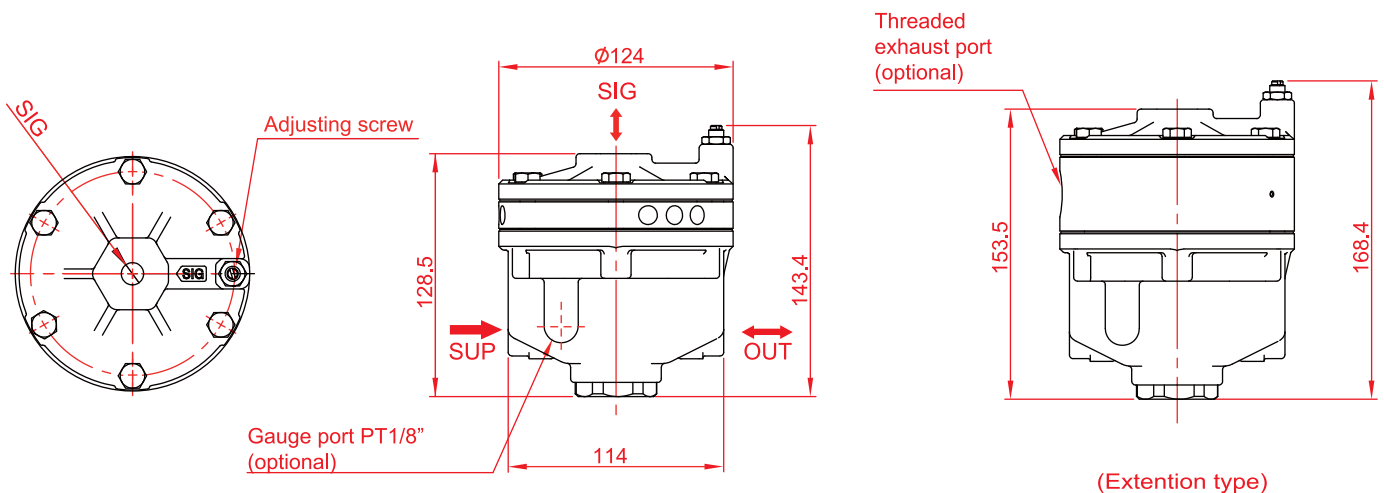

# Applications

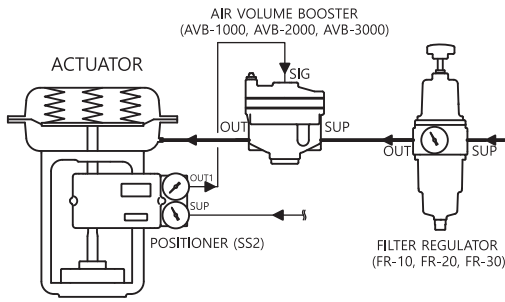

**SINGLE ACTING**

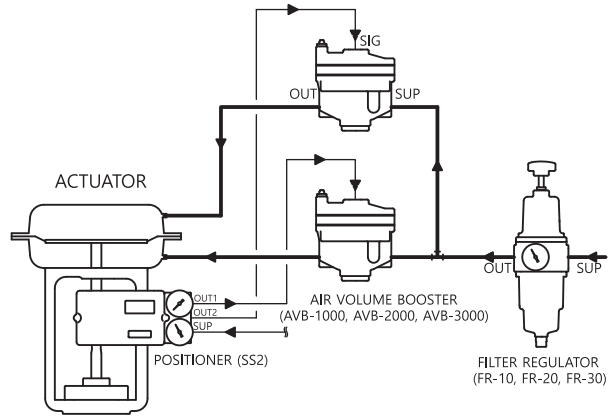

**DOUBLE ACTING**

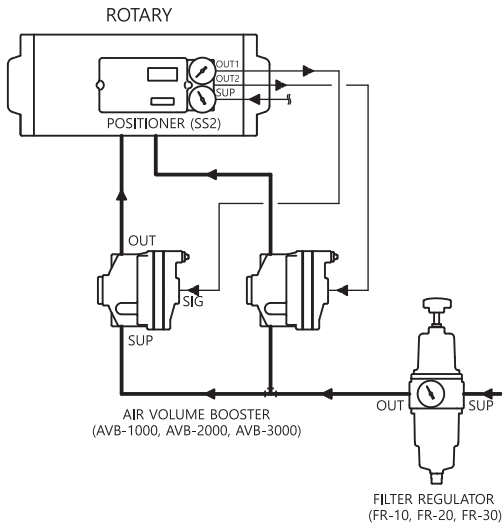

**ROTARY ACTUATOR**

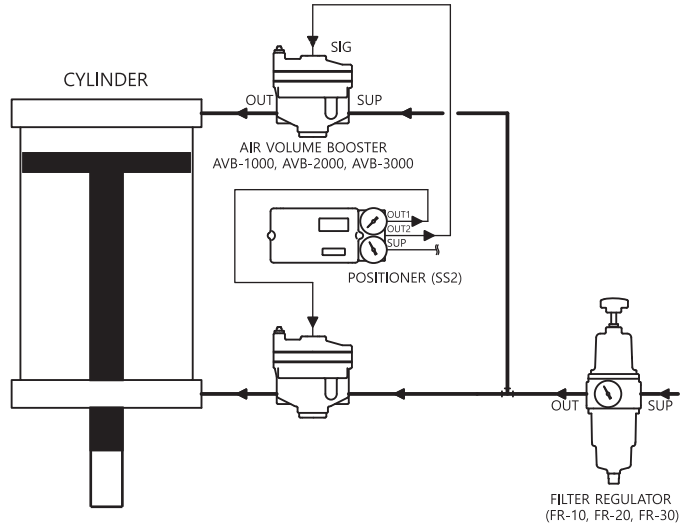

**CYLINDER ACTUATOR**

**ALL-TECHNIK**  
 & Components, Incorporated

All-Technik Bldg. Lot 11 Block 36 San Antonio Avenue  
 San Antonio Valley Sucat Parañaque City Philippines 1715  
 Tel. No.: (+632) 8829-4849; 8829-4850; 8825-2563  
[www.alltechnik.com](http://www.alltechnik.com) [www.atpneumatik.com](http://www.atpneumatik.com)





www.atpneumatik.com

# LSB Series Valve Position Monitor



All innovation  
on driving your valve automation



## Valve Position Monitor

**Robust valve position monitor with a good recognizable beacon, various switches and feedback options**



### Features

- ▶ Weatherproof to IP66 & 67 (optionally IP68)
- ▶ Rugged aluminum die-cast housing
- ▶ Various switches and sensors (available with Honeywell / P&F)
- ▶ NAMUR mounting shaft or fork lever shaft adjustable for a non-NAMUR pneumatic actuator

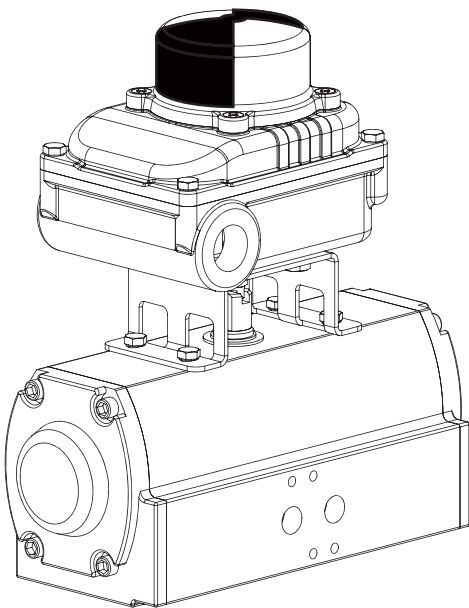

### Options

- ▶ 2 x SPDT mechanical limit switch
- ▶ 4 x SPDT mechanical limit switch
- ▶ 2 x P&F proximity sensor

### Specifications

Model	LSB-1000
Protection Class	IP66 & 67 (optionally IP68)
Switches / Sensors	See page 5
Operating Temperature	- 40 ~ +100°C (-40 ~ +212°F)
Electrical Connections	PF 1/2, NPT 1/2, M20 x 1.5, PG13.5
Body Material / Painting	Aluminum die-cast / powdered-coating
Weight	0.8 kg



< With beacon indicator >



< With bottom indicator >



< With stainless steel 316 housing >



**Explosion proof robust valve position monitor with a good recognizable beacon, bottom indicator, various switches and feedback options**

### Features

- ▶ Flameproof ATEX / IECEx / TR-CU / KC Ex d IIC
- ▶ Rugged aluminum die-cast housing or optionally stainless steel 316 housing
- ▶ Optionally dual beacons or bottom indicator
- ▶ Various switches and sensors (available with Honeywell / P&F / Hermetically-sealed magnetic sensor)
- ▶ NAMUR mounting shaft or fork lever shaft adjustable for a non-NAMUR pneumatic actuator

### Options

- ▶ 4 x SPDT mechanical limit switch
- ▶ 4 x P&F proximity sensor
- ▶ 4 x Hermetically-sealed magnetic sensor
- ▶ 4 - 20mA output position transmitter

### Specifications

Model	LSB-30xx	LSB-31xx
Explosion proof / Protection Class	ATEX / IECEx / TR-CU / KC - Ex d IIC - IP66&67 (optionally IP68)	
	Ambient Temperature	T6 : - 40 ~ +75°C
		T5 : - 40 ~ +90°C
	T4 : - 40 ~ +110°C	
Switches / Sensors	See page 5	
Operating Temperature	- 40 ~ +110°C (- 40 ~ +230°F)	
Electrical Connections	PT 3/4, NPT 3/4, PF 1/2, NPT 1/2, M20 x 1.5	NPT 3/4, NPT 1/2
Body Material / Painting	Aluminum die-cast / powdered-coating	Stainless steel 316 / 316L
Weight	2 kg	4 kg

## Valve Position Monitor



With built-in solenoid valve

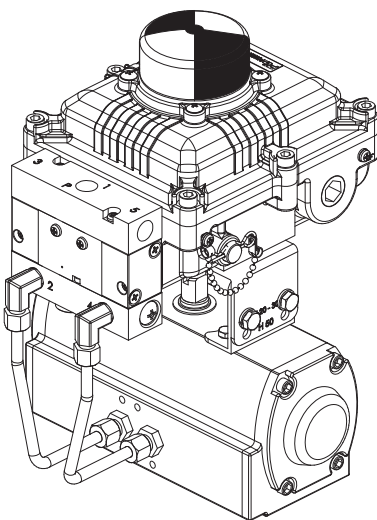

**Explosion-proof robust valve position monitor with built-in solenoid and more feedback options and designed to provide an outstanding performance under harsh working environments**

### Features

- ▶ Flameproof ATEX / IECEx / TR-CU / KC Ex d IIB+H<sub>2</sub> T6
- ▶ Rugged aluminum die-cast or stainless steel housing
- ▶ Compact single unit with built-in solenoid valve
- ▶ More economical in costs and simple wiring to a single unit comparison with separate installations of explosion proof limit switches and explosion proof solenoid valve
- ▶ Auto / Manual button easy to convert
- ▶ NAMUR mounting shaft or fork lever shaft adjustable for a non-NAMUR pneumatic actuator

### Options

- ▶ 4 x SPDT mechanical limit switch
- ▶ 4 x P&F proximity sensor
- ▶ 2 x Hermetically-sealed magnetic sensor
- ▶ 4 - 20mA output position transmitter

### Specifications

Model	LSB-7000	LSB-7100	LSB-7200
Explosion proof / Protection Class	ATEX / IECEx / TR-CU / KC - Ex d IIB+H <sub>2</sub> - IP66&67		
Operating Air Pressure	1.5 ~ 10 bar		
Air Supply Pressure	Max. 10 bar		
Mechanical Switches/Proximity Sensors	See page 5		
Operating Voltage of Solenoid Valve	24 VDC / 48 VDC / 110 VAC / 220 VAC		
Manual Override of Solenoid Valve	Push button type		
Response Time of Solenoid Valve	25 ms		
Coil Insulation Class	Class F		
Operating Temperature	-30 ~ +75 °C		
Pneumatic Connections	PT(Rc) 1/4, NPT 1/4		NTP 1/4
Electrical Connections	PT 1, NPT 1 PT 3/4, NPT 3/4, PF 1/2, NPT 1/2		NPT 1, NPT 3/4, NPT 1/2
Body Material	Aluminum die-cast		Stainless steel 316
Solenoid Valve Body Material	Aluminum die-cast	Stainless steel 316	
Weight	2.5 kg	3.5 kg	5.8 kg



**Solenoid Valve**

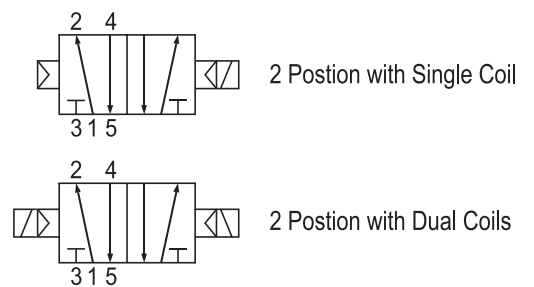
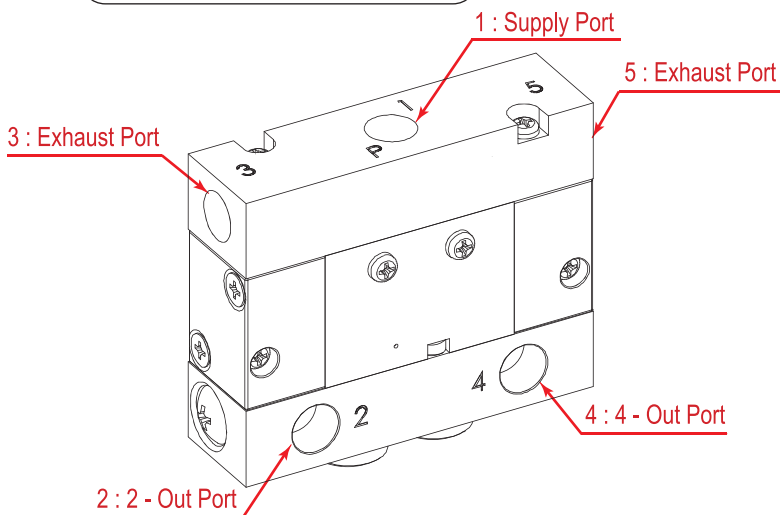

< Symbols of Operation >

Supply Air		Filtered, compressed, dry and non-oiled air
Supply Air Pressure	2 position with single coil	1.5 ~ 9.9 bar
	2 position with dual coils	1.0 ~ 9.9 bar
Eff. Sectional Area (5 kfg/cm <sup>2</sup> )		19.0 mm <sup>2</sup>
Manual Override		Push button type
Response Time		25 ms or less
Max. Working Frequency		5 c/sec
Power Consumption		AC : 4.5 / 3.6VA (60Hz/50Hz) DC : 2.8W
Coil Insulation Class		Class F or equivalent
Permissible Voltage Variation		±10% of rated voltage
Lubrication		Not required

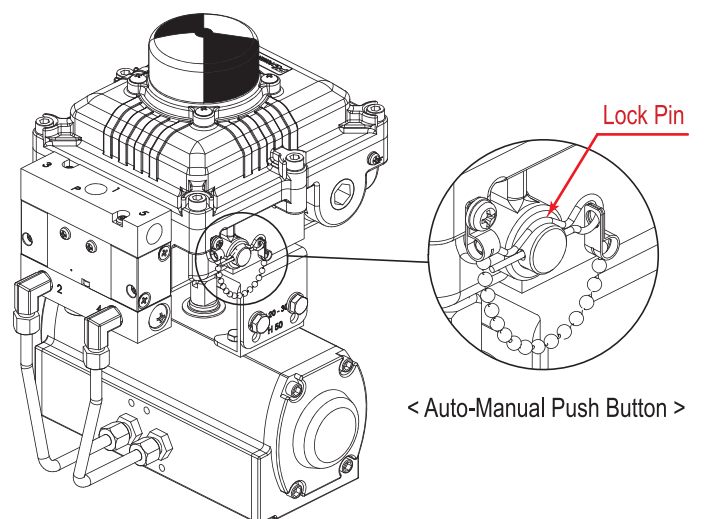

< Auto-Manual Push Button >



## Mechanical Switches



< SPDT Mechanical Switch - GSM >

< SPDT Mechanical Switch - V7/V15 >

< DPDT Mechanical Switch - 22104 >

Maker	Standard
Switch type	SPDT (Form C)
Contacts	Silver-plated
Approvals	UL, CSA
Electrical Rating	
16 amps / 250 VAC	
16 amps / 8 VDC , 10amps / 30 VDC	
Operating Temp.	-30 ~ +130°C

Maker	Honeywell
Switch type	SPDT (Form C)
Contacts	Silver-plated or gold-plated
Approvals	UL, CSA
Electrical Rating	
Silver : 16 amps / 125 / 250 VAC	
Gold : 0.1 amps / 125 / 250 VAC	
Operating Temp.	-40 ~ +125°C

Maker	Licon
Switch type	DPDT (Form CC)
Contacts	Silver-plated
Approvals	UL, CSA
Electrical Rating	
10 amps / 125 / 250 VAC	
10 amps / 28 VDC	
Operating Temp.	-30 ~ +80°C

## Proximity Sensors



Part Number / Maker	NJ2-V3-N / P&F
Switching element function	NAMUR NC
<b>Nominal Ratings</b>	
Nominal voltage	8.2 VDC
Switching frequency	0 ~ 1000 Hz
Hysteresis	0.01 ~ 0.1 mm
Current consumption	
Measuring plate not detected	> 3 mA
Measuring plate detected	< 1 mA
Operating Temperature	-25 ~ +100°C

Part Number / Maker	NJ2(4)-12GK-SN / P&F
Switching element function	NAMUR NC
<b>Nominal Ratings</b>	
Nominal voltage	8 VDC
Switching frequency	0 ~ 2000 Hz
Hysteresis	3%
Current consumption	
Measuring plate not detected	> 3 mA
Measuring plate detected	< 1 mA
Operating Temperature	-40(-50) ~ +100°C

## Magnetic Proximity Sensors



Part Number / Maker	MS Series / Power-genex
Switch type	SPDT (Form C)
Contacts	Rhodium / Tungsten
Approvals	UL, CSA
Electrical Ratings	
MS20 : 830 mA / 24VDC, 180 mA / 120VAC	
MS25 : 1 A / 24VDC, 200 mA / 120VAC	
MS100 : 2 A / 24VDC, 3 A / 120VAC, 1.5 A / 240VAC	
Operating Temperature	-40 ~ +130°C

Part Number / Maker	ESI-V3-CR / Euroswitch
Switch type	SPDT (Form C)
Contacts	Rhodium
Approvals	ATEX / IECEx / INMETRO Ex ia IIC T6
Electrical Ratings	
830 mA / 24VDC, 180 mA / 120VAC	
Ex : Ui = 30V, Ii = 250mA, Pi = 1.3W	
Operating Temperature	-20 ~ +80°C



Switch Box Type	Body Material	Switches / Sensors	Position Transmitter	Explosion Proof	Beacon / Indicator	Electrical Connections	Number of Electrical Connections	Feedback Shaft	Mounting Bracket	Coil type	Power Supply	Pneumatic Connections
<b>LSB-1</b> Weatherproof type	die-cast	<b>Mechanical switches</b> 0 (2) SPDT 2 (4) SPDT  <b>P&amp;F Sensors</b> 4 (2) NJ2-V3-N 7 (2) NBB3-V3-Z4 9 (2) NBB2-V3-E2 <b>Autonics sensors</b> 8 (2) PSN17-5D  <b>Honeywell</b> J (2) SPDT  <b>Hermetically-sealed sensors</b> A (2) MS-25 (1A) C (2) MS-20 (0.8A)		<b>7</b> Weatherproof IP67  <b>8</b> Weatherproof IP68	<b>N</b> None  <b>A</b> Beacon indicator 90° (Open / Close)  <b>T</b> T port indicator  <b>L</b> L port indicator	<b>C</b> PF 1/2  <b>D</b> NPT 1/2  <b>E</b> M20 x 1.5  <b>H</b> PG 13.5		<b>Rotary type</b> <b>N</b> NAMUR shaft  <b>F</b> Fork lever  <b>Linear type</b> <b>B</b> Stroke 5 ~ 65mm <b>C</b> Stroke 5 ~ 130mm  <b>D</b> Stroke 80 ~ 200mm	<b>N</b> None  <b>1</b> 30x80 x20(H)  <b>2</b> 30x80 x30(H)  <b>3</b> 30x130 x30(H)  <b>4</b> 30x130 x50(H)			
<b>LSB-3</b> Explosion-proof type	<b>0</b> Aluminum die-cast  <b>1</b> Stainless steel 316  <b>2</b> Stainless steel 316L (On request)	<b>Mechanical switches</b> 0 (2) SPDT 2 (4) SPDT 3 (2) DPDT  <b>P&amp;F sensors</b> 4 (2) NJ2-V3-N 5 (4) NJ2-V3-N 6 (2) NJ2-12GK-SN or NJ4-12GK-SN 7 (2) NBB3-V3-Z4 9 (2) NBB2-V3-E2 S(2) NJ2-12GM40-E2 R (2) NCN4-V3-NO T (2) SJ3 3.5-S1N  <b>Sensors</b> 8 (2) PSN17-5D PNP or NPN N (2) D2VW-5L1-1M  <b>Hermetically-sealed proximity sensors</b>	<b>0</b> None  <b>T</b> 4~20mA output signal  <b>1</b> 0~1k output signal  <b>2</b> 0~10k output signal	<b>K7</b> KC Ex d IIC - IP67  <b>A7</b> ATEX / IECEx Ex d IIC - IP67  <b>I7</b> KC Ex ia IIC - IP67  <b>K8</b> KC Ex d IIC - IP68  <b>A8</b> ATEX / IECEx Ex d IIC - IP68  <b>I8</b> KC Ex ia IIC - IP68	<b>N</b> None  <b>A</b> Beacon indicator 90° (Open / Close)  <b>B</b> Bottom indicator 90° (Open / Close)  <b>C</b> Beacon & bottom indicator 90° (Open / Close)  <b>T</b> T port indicator  <b>L</b> L port indicator	<b>A</b> PF 3/4  <b>B</b> NPT 3/4  <b>C</b> PF 1/2  <b>D</b> NPT 1/2  <b>E</b> M20 x 1.5  <b>I</b> M25 x 1.5	<b>2</b> 2 pcs  <b>3</b> 3 pcs	<b>Rotary type</b> <b>N</b> NAMUR shaft  <b>F</b> Fork lever  <b>Linear type</b> <b>B</b> Stroke 5 ~ 65mm  <b>C</b> Stroke 5 ~ 130mm  <b>D</b> Stroke 80 ~ 200mm	<b>M</b> Multi-size Bracket  <b>R</b> Other on request			
<b>LSB-7</b> Explosion-proof type (built-in solenoid v/v)	<b>0</b> Aluminum die-cast  <b>1</b> Aluminum die-cast switch box / 316SS solenoid V/V  <b>2</b> 316SS switch box & solenoid V/V	<b>(Amp@24VDC)</b> A (2) MS-25 (1A) B (4) MS-25 (1A) C (2) MS-20 (0.8A) D (4) MS-20 (0.8A) E (2) MS-100 (2A) F (4) MS-100 (2A) G (2) ESI-V3-CR H (4) ESI-V3-CR I (2) MONAS I(2A)  <b>Honeywell switches</b> J (2) SPDT(SILVER) K (4) SPDT(SILVER) L (2) SPDT(GOLD) M (4) SPDT(GOLD)  <b>Other on request</b>	<b>0</b> None  <b>T</b> 4~20mA output signal	<b>K</b> KC Ex d IIB+H2 - IP67  <b>A</b> ATEX / IECEx Ex d IIB+H2 - IP67	<b>N</b> None  <b>A</b> Beacon indicator 90° (Open / Close)  <b>T</b> T port indicator  <b>L</b> L port indicator	<b>A</b> PF 3/4  <b>B</b> NPT 3/4  <b>C</b> PF 1/2  <b>D</b> NPT 1/2  <b>E</b> M20 x 1.5  <b>I</b> M25 x 1.5  <b>F</b> PF 1  <b>G</b> NPT 1	<b>2</b> 2 pcs  <b>3</b> 3 pcs  <b>4</b> 4 pcs	<b>Rotary type</b> <b>N</b> NAMUR shaft  <b>F</b> Fork lever  <b>Linear type</b> <b>B</b> Stroke 5 ~ 65mm  <b>C</b> Stroke 5 ~ 130mm  <b>D</b> Stroke 80 ~ 200mm	<b>Rotary type</b> <b>N</b> None  <b>M</b> Multi-size Bracket  <b>R</b> Other on request	<b>N</b> None  <b>S</b> Single coil  <b>D</b> Dual coil	<b>N</b> None  <b>A</b> 220VAC  <b>B</b> 110VAC  <b>C</b> 24VDC  <b>D</b> 48VDC	<b>N</b> None  <b>1</b> PT 1/4  <b>2</b> NPT 1/4
<b>Switch Box Type</b>	<b>Body Material</b>	<b>Switches / Sensors</b>	<b>Position Transmitter</b>	<b>Explosion Proof</b>	<b>Beacon / Indicator</b>	<b>Electrical Connections</b>	<b>Number of Electrical Connections</b>	<b>Feedback Shaft</b>	<b>Mounting Bracket</b>	<b>Coil type</b>	<b>Power Supply</b>	<b>Pneumatic Connections</b>

## Valve Position Monitor

### < LSB-1000 >

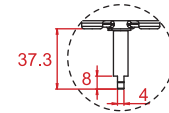
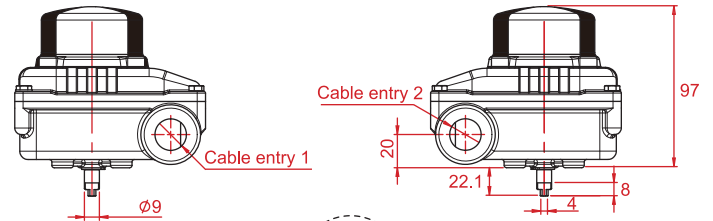
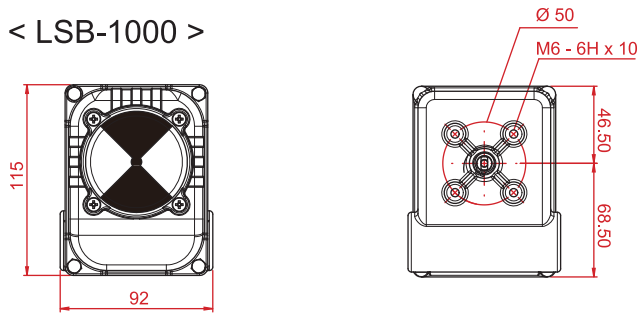

LSB-1000 / 3000  
Multi-bracket shaft

### < LSB-3000 - Beacon Indicator >

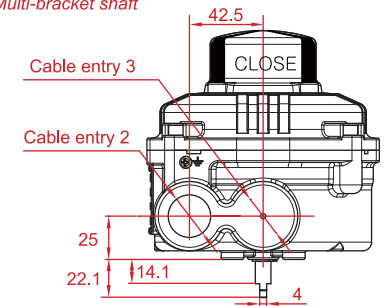
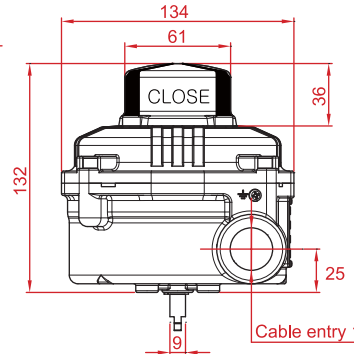
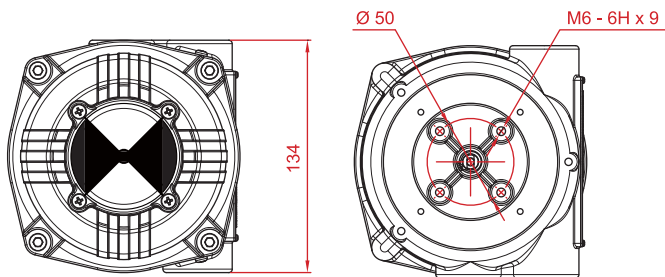

### < LSB-3000 - Bottom Indicator >

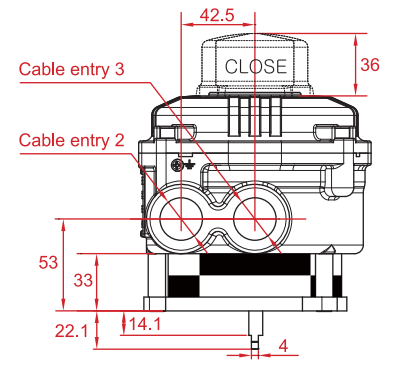
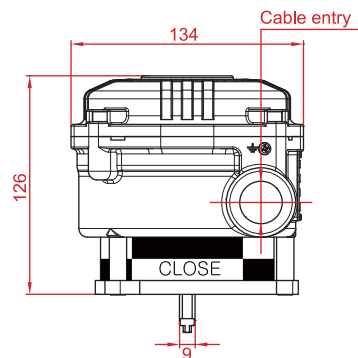
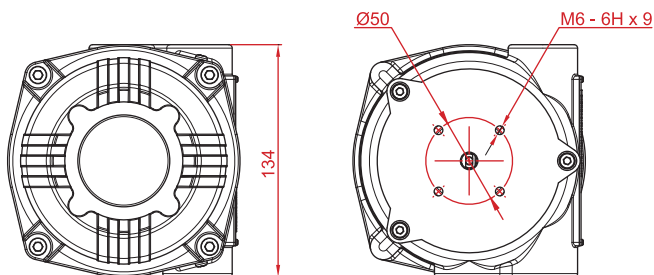

### < LSB-7000 >

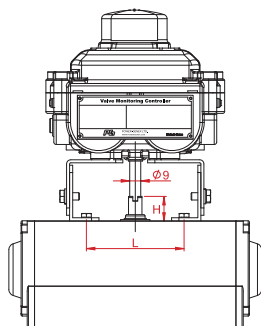

#### < Dual Coil Type >

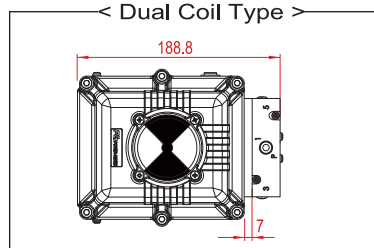

#### < Single Coil Type >

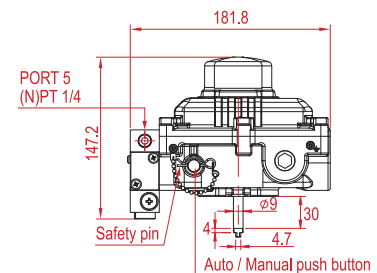
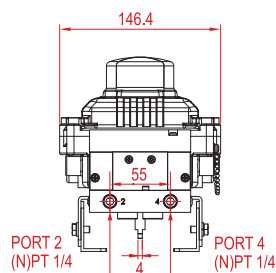
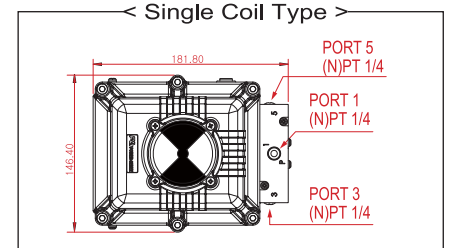

#### Size Variation of Multi-Size Bracket

- 1) 80 x 30 x 20 (H), 4) 130 x 30 x 20 (H)
- 2) 80 x 30 x 30 (H), 5) 130 x 30 x 30 (H)
- 3) 80 x 30 x 50 (H), 6) 130 x 30 x 50 (H)

H : Rotary Actuator Shaft Height  
L : Length ( 80 or 130mm )

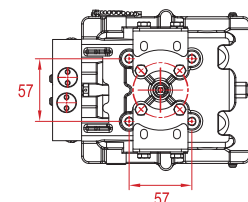
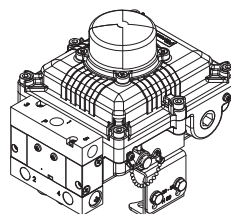

## < Bracket : LSB-1000 / 3000 >

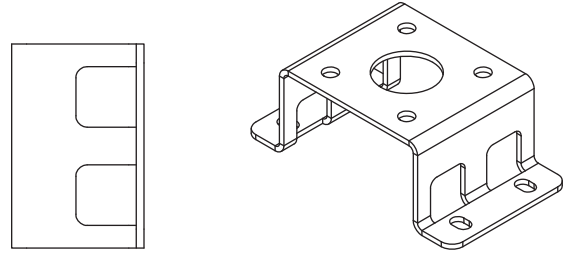
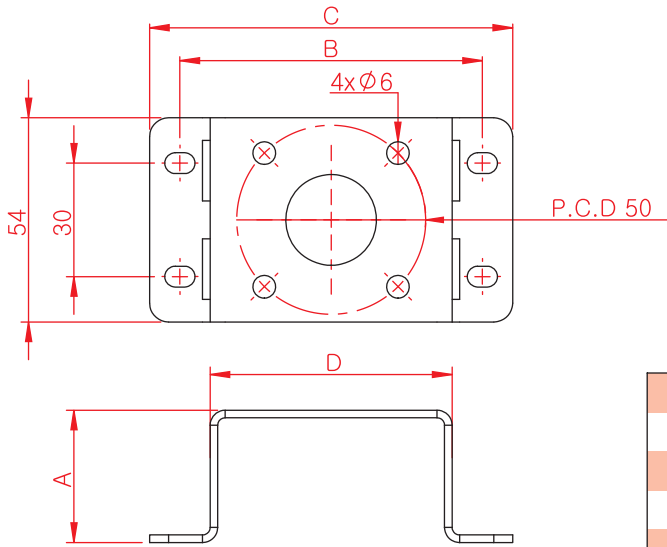

	A	B	C	D
30x80x20	35	80	96	64
30x80x30	45	80	96	64
30x130x30	45	130	150	100
30x130x50	65	130	150	100

## < Wiring Diagram >

	LSB-1000 / 3000 / 7000	LSB-3000 / 7000
Mechanical Switches / Magnetic Sensors (SPDT)		
Mechanical Switches (DPDT)		
Proximity Sensors (P&F)		

## Valve Position Monitor

### Linear valve position monitor

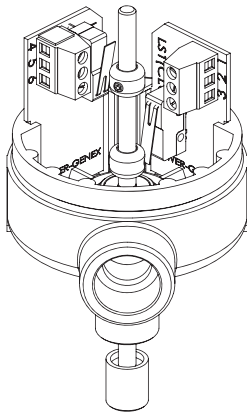

#### Features

- ▶ Weatherproof to IP66
- ▶ Easy to mount and compact for angle seat valve or diaphragm valve

#### Specifications

	LSB-2000
Protection Class	IP66
Specifications of Switches	2 x SPDT (250 VAC @ 10.1A)
Linear Operating Stroke	8 ~ 30mm
Operating Temperature	-20 ~ +60°C (-4 ~ +140°F)
Electrical connections	PF 1/2
Body material	PA
Weight	0.5 kg

#### How to Order

**LSB-2000** - Stroke "A" - Mounting Threads "B" - Feedback Shaft Length "C"

Description	Code
Stroke (A) :	On request (8mm ~ 30mm)
Mounting Threads (B):	On request (Ex. M30 x 2.0)
Feedback Shaft Length (C):	On request

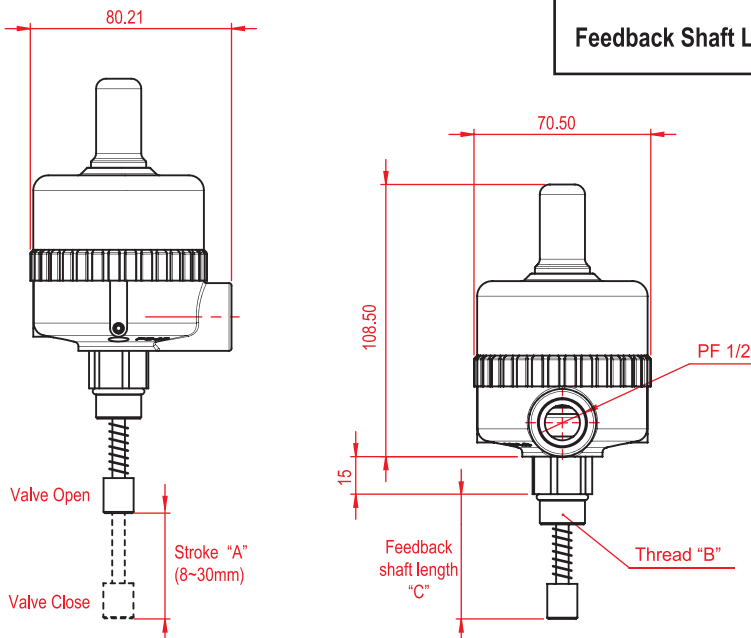

#### < SPDT Mechanical Switch - OMRON >

Technical Data	
Switch type	SPDT (Form C)
Contacts	Silver-plated
Approvals	UL, CSA
Electrical Rating	10.1 Amps / 250 VAC
Operating Temp.	-25 ~ +85°C

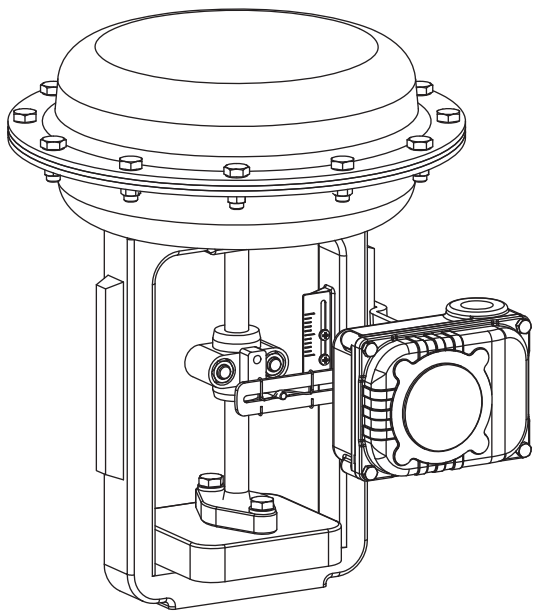

< Linear type - LSB-1000 >

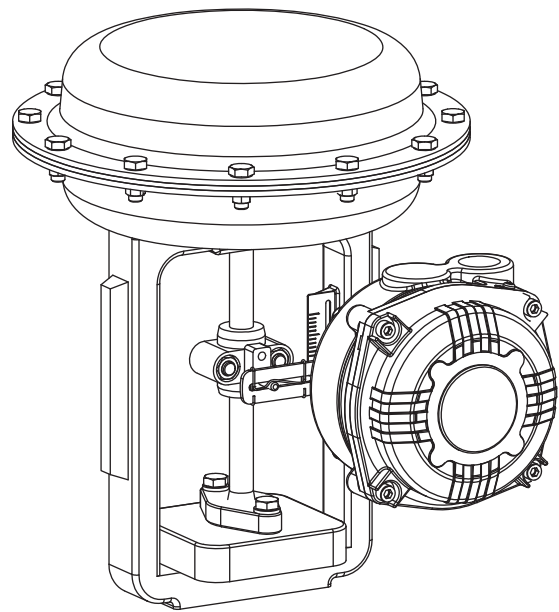

< Linear type - LSB-3000 >

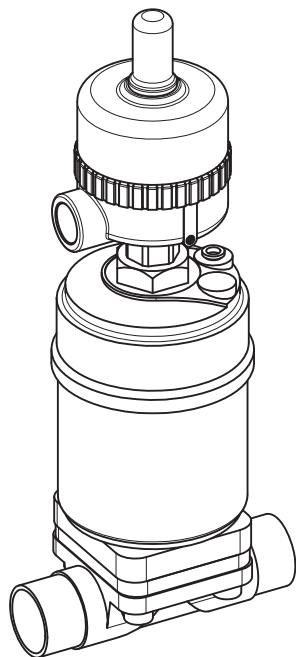

< Linear type - LSB-2000 >

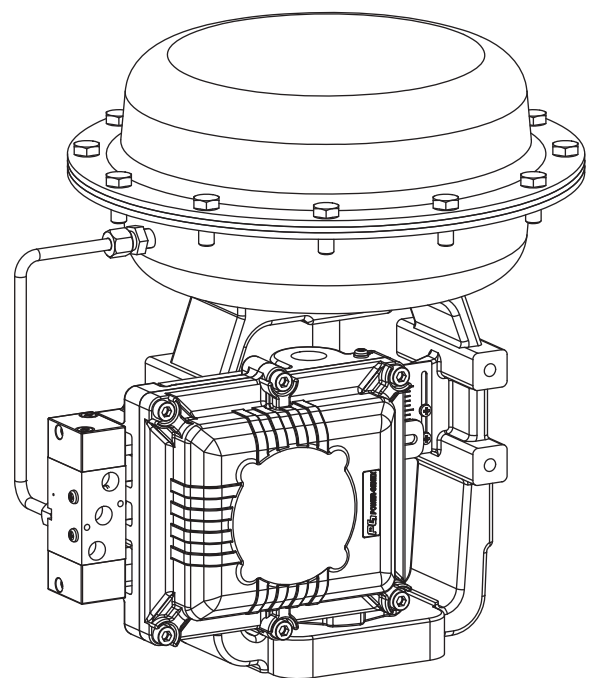

< Linear type - LSB-7000 >

# Solenoid Valve



**ESV-S**  
(5/2 way)



**ESV-SS**  
(SS316 valve body)



**ESV-SC**  
(SS316)



**ESV-3**  
(3/2 way)



**ESV-3S**  
(SS316 valve body)



**ESV-31**  
(3/2 way)

## Features

- ▶ Flameproof ATEX / IECEx / KC Ex d IIC
- ▶ Rugged aluminum die-cast housing or optionally stainless steel 316 valve body
- ▶ Convertible from 5/2 way to 3/2 way
- ▶ Rotatable valve head for optimal mounting
- ▶ Direct NAMUR mounting or screw mounting

## Mounting

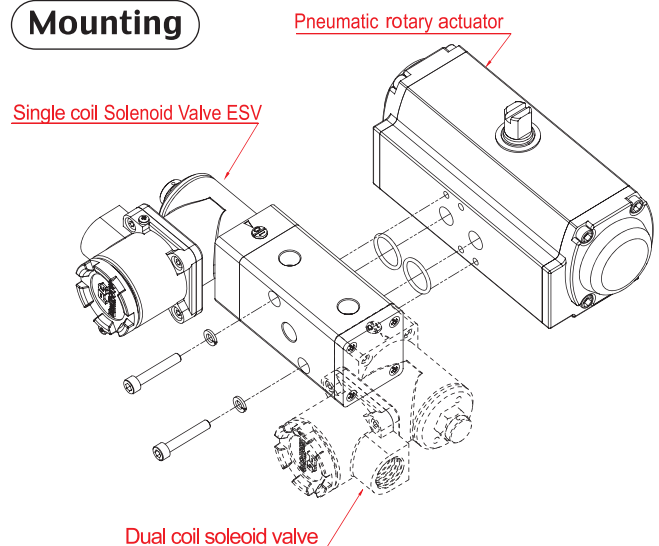

**ALL-TECHNIK**  
& Components, Incorporated

All-Technik Bldg. Lot 11 Block 36 San Antonio Avenue  
San Antonio Valley Sucat Parañaque City Philippines 1715  
Tel. No.: (+632) 8829-4849; 8829-4850; 8825-2563  
[www.alltechnik.com](http://www.alltechnik.com) [www.atpneumatik.com](http://www.atpneumatik.com)